

# HP Archive

This vintage Hewlett Packard document was  
preserved and distributed by

**[www. hparchive.com](http://www.hparchive.com)**

Please visit us on the web !

Scanned by on-line curator: Tony Gerbic

**\*\* For FREE Distribution Only \*\*\***

**HEWLETT-PACKARD**  
MAY 1964

# 150A

OSCILLOSCOPE

OPERATING AND SERVICING MANUAL



OPERATING AND SERVICING MANUAL  
FOR

MODEL 150A  
HIGH FREQUENCY OSCILLOSCOPE  
Serial 1190 and Above  
And  
MODEL 152A  
DUAL TRACE AMPLIFIER  
Serial 1086 and Above

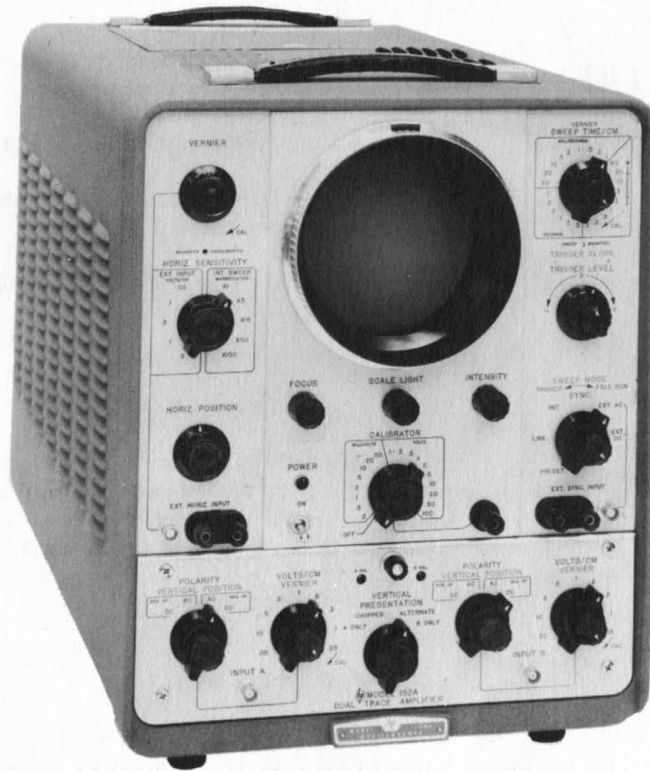

Copyright 1956 by Hewlett-Packard Company

The information contained in this booklet is intended for the operation and maintenance of Hewlett-Packard equipment and is not to be used otherwise or reproduced without the written consent of the Hewlett-Packard Company.

HEWLETT-PACKARD COMPANY  
275 PAGE MILL ROAD, PALO ALTO, CALIFORNIA, U.S.A.

150A001-1

## 150A SPECIFICATIONS

### SWEEP GENERATOR

INTERNAL SWEEP:	24 calibrated ranges provide sweep speeds from 0.1 $\mu$ sec/cm to 5 sec/cm; accurate to within 3%.  A vernier control provides continuous adjustment of sweep speed between calibrated ranges and extends slowest sweep to 15 sec/cm.
MAGNIFICATION:	5 calibrated ranges, X1, X5, X10, X50 and X100 magnifies center portion of unmagnified trace; increases fastest sweep speed to .02 $\mu$ sec/cm except 1 $\mu$ X50 magnification and 2 $\mu$ X100 magnification. X1 and X5 ranges retain accuracy of original sweep.
SYNCHRONIZATION:	Internal, from line power or vertical input signal which causes 1/2 cm or more vertical deflection. External, either capacitive or direct coupled with 1/2V p-p or more.
SYNC CONTROL:	Sweep can be triggered from either a positive- or a negative going voltage; the triggering voltage level of external sync signals is continuously adjustable from -30 to +30 volts.  Switch position automatically provides optimum sync stability for majority of uses.
SINGLE SWEEP:	Switch in top access provides single-sweep operation.
SAWTOOTH OUTPUT:	+20 to -20 volt sawtooth output available from connector in top access.
GATE OUTPUT:	20-volt positive pulse for duration of sweep available from connector in top access.

### HORIZONTAL AMPLIFIER

BANDWIDTH:	Direct current to 500 kilocycles.
SENSITIVITY:	5 calibrated ranges provide sensitivities from 0.2 volt/cm to 5 volts/cm. A vernier control provides continuous adjustment between calibrated ranges and extends the minimum sensitivity to 15 volts/cm.
INPUT IMPEDANCE:	1 megohm shunted by 40 $\mu$ f.

### CALIBRATOR

OUTPUT:	1000-cycle square wave having 1- $\mu$ sec rise and decay time available at front-panel connector.  18 calibrated ranges provide from 0.2 millivolt to 100 volts peak-to-peak, accurate to within 3%.
---------	---

## CATHODE RAY TUBE

TYPE:	5 AMP- mono-accelerator, flat face, available with P1, P2, P7 or P11 screen. 5000-volt accelerating potential.
DEFLECTION PLATE CONNECTIONS:	Both screw and pin-type terminals in top access receive wires or special connector assembly for connection to plates.
INTENSITY MODULATION:	Terminals inside top access to receive +20 pulse for blanking CRT trace of normal intensity.
REPLACEABILITY:	CRT bezel removes with 15° twist for replacement of graticule or CRT from the front panel.  CRT bezel provides firm mounting for standard oscilloscope cameras.
POWER REQUIREMENTS:	115/230 VAC ±10%, 50/60 cycles, approximately 500 watts.
SIZE:	13-1/2" wide x 17-1/4" high x 25" deep.
WEIGHT:	Net weight 80 pounds; shipping weight 104 pounds.

## Ⓢ 152 DUAL TRACE AMPLIFIER

BANDWIDTH:	Direct Current to 10 megacycles; rise time 0.035 microsecond.
SENSITIVITY:	9 calibrated ranges provide sensitivities from 0.05 to 20 volt/cm, 5%. Vernier control provides continuous adjustment between calibrated ranges and extends the minimum sensitivity to 50 volts/cm.
INPUT IMPEDANCE:	1 megohm shunted by 40 μf each channel.
DUAL TRACE PRESENTATIONS	Simultaneous traces obtained either by alternate sweeping or by 100-kilocycle chopping, as selected. Chopping lines between traces are blanked.  Channels are completely independent and have identical operating controls.  Pos-Up-Pos Down switch provided.

TABLE OF CONTENTS  
FOR  
MODEL 150A AND MODEL 152A  
HIGH FREQUENCY OSCILLOSCOPES

Para.		Page	Para.		Page
SECTION I GENERAL DESCRIPTION			4-2	Replacing the Air Filter . . .	4-1
1-1	General Information . . . . .	1-1	4-3	Removing the Cabinet . . . . .	4-1
1-2	Damage in Transit . . . . .	1-1	4-4	Connecting for 230-Volt Power Lines . . . . .	4-1
1-3	Power Line Voltages . . . . .	1-1	4-5	Servicing Etched Circuits . . .	4-1
1-4	Power Cord . . . . .	1-1	4-6	Tube Replacement Chart . . .	4-3
1-5	Cooling . . . . .	1-1	4-7	Isolating Troubles to Major Sections . . . . .	4-3
1-6	Overload Relay . . . . .	1-1	4-8	Adjusting the Low-Voltage Power Supplies . . . . .	4-3
SECTION II OPERATING INSTRUCTIONS			4-9	Adjusting the High-Voltage Power Supply . . . . .	4-9
2-1	High Voltage Time Delay . . .	2-1	4-10	Replacing and Adjusting the CRT . . . . .	4-9
2-2	Controls and Terminals . . .	2-1	4-11	Adjusting the Calibrator . . .	4-11
2-2A	Internal Sweep Controls . . .	2-1	4-12	Adjusting the Main Horizontal Amplifier. . . . .	4-11
2-2B	Horizontal Input Controls. . .	2-2	4-12A	Main Horizontal Gain Adjustment . . . . .	4-11
2-2C	Dual Channel Amplifier Controls . . . . .	2-2	4-12B	X100 Magnification Calibration . . . . .	4-13
2-2D	CRT Panel Controls . . . . .	2-3	4-12C	X5 to X100 Magnification Centering and X1 Centering.	4-13
2-2E	Top Access Controls . . . . .	2-3	4-12D	Main Horizontal Amplifier Frequency Response Adjustment . . . . .	4-14
2-3	Operating Procedures . . . . .	2-3	4-13	Adjusting the Ext. Horiz. Input Preamp. . . . .	4-15
2-4	Vertical AC or DC Coupling . .	2-3	4-13A	Horiz. Balance Adjustment . . . . .	4-15
2-5	Use of Chopped or Alternate Sweep . . . . .	2-4	4-13B	Ext. Horiz. Input Volts/CM Calibration . . . . .	4-15
SECTION III THEORY OF OPERATION			4-13C	Ext. Horiz. Input . . . . .	4-17
3-1	General Content . . . . .	3-1	4-14	Adjusting the Sync Circuit . .	4-17
3-2	Overall Operation . . . . .	3-1	4-15	Adjusting the Preset Sensi- tivity of the Sweep Generator . . . . .	4-18
3-3	Synchronizing Circuit . . . . .	3-3	4-16	Calibrating the Sweep Generator . . . . .	4-18
3-4	Sweep Generator . . . . .	3-5	4-16A	Sweep Amplitude Adjustment . . . . .	4-18
3-5	Feedback Integrator and Diode Switch . . . . .	3-6	4-17	Adjusting Gain and Fre- quency Response of Main Vertical Amplifier . . . . .	4-21
3-6	Schmitt Trigger Circuit . . . .	3-7	4-18	Adjusting Model 152A Dual Trace Amplifier. . . . .	4-21
3-7	Horizontal Amplifier. . . . .	3-7	4-18A	Vertical Centering Adjustments . . . . .	4-21
3-8	Main Vertical Amplifier . . . .	3-8	4-18B	Neutralizing Adjustments. . .	4-21
3-9	Model 152 Dual Trace Amplifier Plug-In Unit. . . . .	3-9	4-18C	Output Frequency Response Adjustment . . . . .	4-23
3-10	Calibrator . . . . .	3-11			
3-11	Regulated Low-Voltage Power Supply . . . . .	3-11			
3-12	Regulated High-Voltage Power Supply . . . . .	3-13			
3-13	Single Sweep and Delayed Sweep Operation . . . . .	3-13			
SECTION IV MAINTENANCE					
4-1	Introductory . . . . .	4-1			

## SECTION I

### GENERAL DESCRIPTION

#### 1-1 GENERAL INFORMATION

The Model 150A dc to 10 MC oscilloscope is a general purpose oscilloscope employing a 5-AMP mono-accelerator type cathode ray tube, with unitized, plug-in construction for maximum accessibility and flexibility. It can be used with either internal or external sweeps which can be either internally or externally synchronized. The horizontal amplifier incorporates magnification circuitry which is capable of expanding basic internal sweeps up to 100 times. Thus the internal sweep range extends from .02  $\mu$ sec/cm to 15 sec/cm.

The Model 150A has been designed for use with a variety of vertical amplifier plug-in units to perform many different functions, but for the purpose of explaining scope operation in this manual, it will be assumed that the Model 152A Dual Channel Amplifier is employed. Since the control layout on the front panel has been carefully organized and labeled for convenient operation, most controls will be self-explanatory. However, major controls will be discussed completely in the operating section of the manual. A large fold out view of the panel is included in Section II with all operating controls described.

#### 1-2 DAMAGE IN TRANSIT

After unpacking this instrument should any shipping damage become evident, refer to the "Claim for Damage in Shipment" paragraph on the warranty sheet in this manual.

#### 1-3 POWER LINE VOLTAGES

The Oscilloscope, like other  $\text{hp}$  instruments, is shipped from the factory wired for 115 volt ac line operation unless otherwise specified in the order. However, the instrument may also be operated from a 230 volt ac line source if the proper conversion is made to the power transformer. This conversion is simple, and is described in the Maintenance section.

#### 1-4 POWER CORD

The three conductor power cable supplied with the instrument is terminated in a polarized three prong male connector recommended by the National Electrical Manufacturers' Association. The third contact is an offset, round pin added to a standard two-blade ac plug which grounds the instrument chassis when used with the appropriate receptacle. To use this plug in a standard two contact outlet an adapter should be used to connect the NEMA plug to the two contact system. When the adapter is used the ground connection becomes a short lead from the adapter which can be connected to the outlet mounting box for the protection of operating personnel.

#### 1-5 COOLING

The Model 150A employs a forced draft cooling system to maintain satisfactory operating temperatures within the case. The air intake and air filter is located under the instrument case, and adequate cooling will take place as long as the case is on the instrument and nothing obstructs the filter. Generally, the height of the cabinet feet provide such clearance. Thus the Model 150A can be used in a confined bench set-up as long as the underside of the cabinet is clear, and ambient temperatures are not extreme.

#### 1-6 OVERLOAD RELAY

The Model 150A has an overload-relay which reduces the output voltages of the power supply when:

- 1.) Any series tube on the d-c heater string is removed while the instrument is on.
- 2.) A plug-in vertical amplifier is removed while the instrument is on.
- 3.) A short circuit or excessive loading of any positive-voltage supply occurs.

ADJUST EXTERNAL HORIZONTAL SWEEP SENSITIVITY BETWEEN STEPS ON **EXT INPUT** SIDE OF **HORIZ. SENSITIVITY** CONTROL.

WHEN LIGHTED FASTEST CALIBRATED INTERNAL SWEEP (.02  $\mu$  SEC/CM) IS EXCEEDED, INCREASE SWEEP-TIME OR REDUCE MAGNIFICATION.

WHEN EXTERNAL SWEEPING, SELECT DESIRED SENSITIVITY,  $\pm$  3% WITH VERNIER IN **CAL.**

WHEN INTERNAL SWEEPING, SET TO X1. FOR MAGNIFICATION, PLACE WAVE TO BE MAGNIFIED AT GRATICULE CENTER WITH **HORIZ. POSITION** CONTROL. SELECT DESIRED MAGNIFICATION.

ADJUST HORIZONTAL POSITION OF TRACE.

ADJUST FOR STATIONARY VERTICAL POSITION OF TRACE WITH MAX. TO MIN. OPERATION OF **VOLTS/CM** VERNIER.

SET TO **A ONLY** OR **B ONLY** TO VIEW EITHER INPUT INDIVIDUALLY. SET TO **ALTERNATE** TO VIEW TWO INPUTS SIMULTANEOUSLY. **CHOPPED** INCREASES APPARENT PERSISTENCE. (SEE TEXT)

SELECT TIME OF INTERNAL HORIZONTAL SWEEP.  $\pm$ 3% WITH VERNIER IN **CAL.**

SWITCH OUT OF **CAL.** POSITION TO ADJUST SWEEP TIME BETWEEN STEPS OF **SWEEP TIME/CM** CONTROL.

LIGHTS WHEN **INT SWEEP** MAGNIFICATION IS GREATER THAN X1.

SET TO ZERO, OR, IF NECESSARY, ADJUST TO STABILIZE SWEEP WITH **SWEEP MODE** IN **PRESET**.

SET TO TRIGGER SWEEP FROM EITHER POSITIVE OR NEGATIVE SLOPE OF **SYNC** SIGNAL.

SELECT CHARACTER OF SYNC SIGNAL DESIRED. SET TO **PRESET** FOR BEST STABILITY IN MOST CASES. OTHER:  
1. SET **TRIGGER LEVEL** TO ZERO.  
2. ADVANCE **SWEEP MODE** TO STABILIZE SWEEP.

ADJUST VERTICAL INPUT SENSITIVITY  $\pm$  3% WITH VERNIER IN **CAL.**

SWITCH OUT OF **CAL.** POSITION TO ADJUST VERTICAL SENSITIVITY BETWEEN STEPS OF **VOLTS/CM** SWITCH.

SELECT DESIRED DIRECTION OF INPUT POLARITY DEFLECTION, ALSO **AC** = AC RESPONSE ONLY. **DC** = DC AND AC RESPONSE.

ADJUST VERTICAL POSITION OF **B** INPUT TRACE.

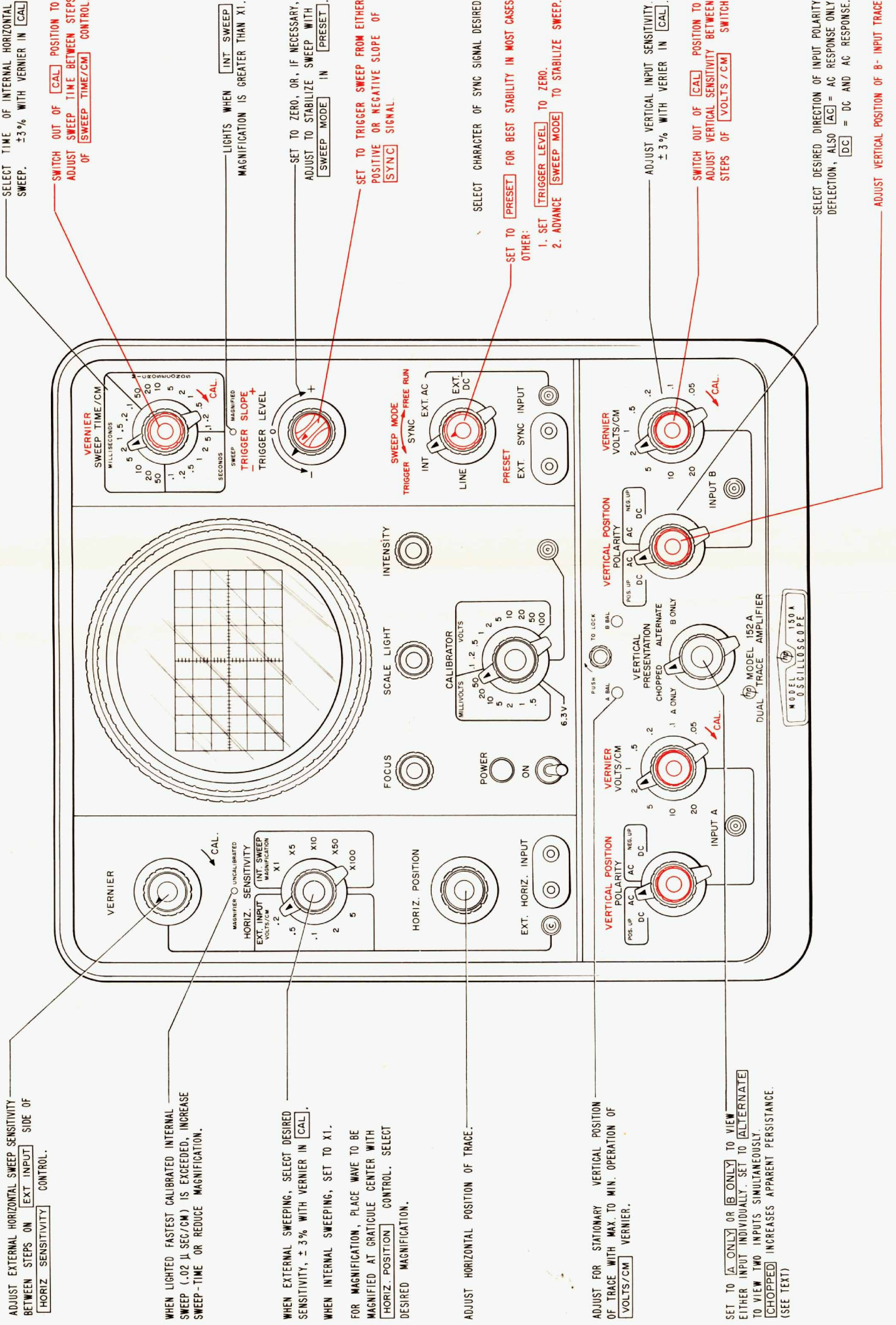
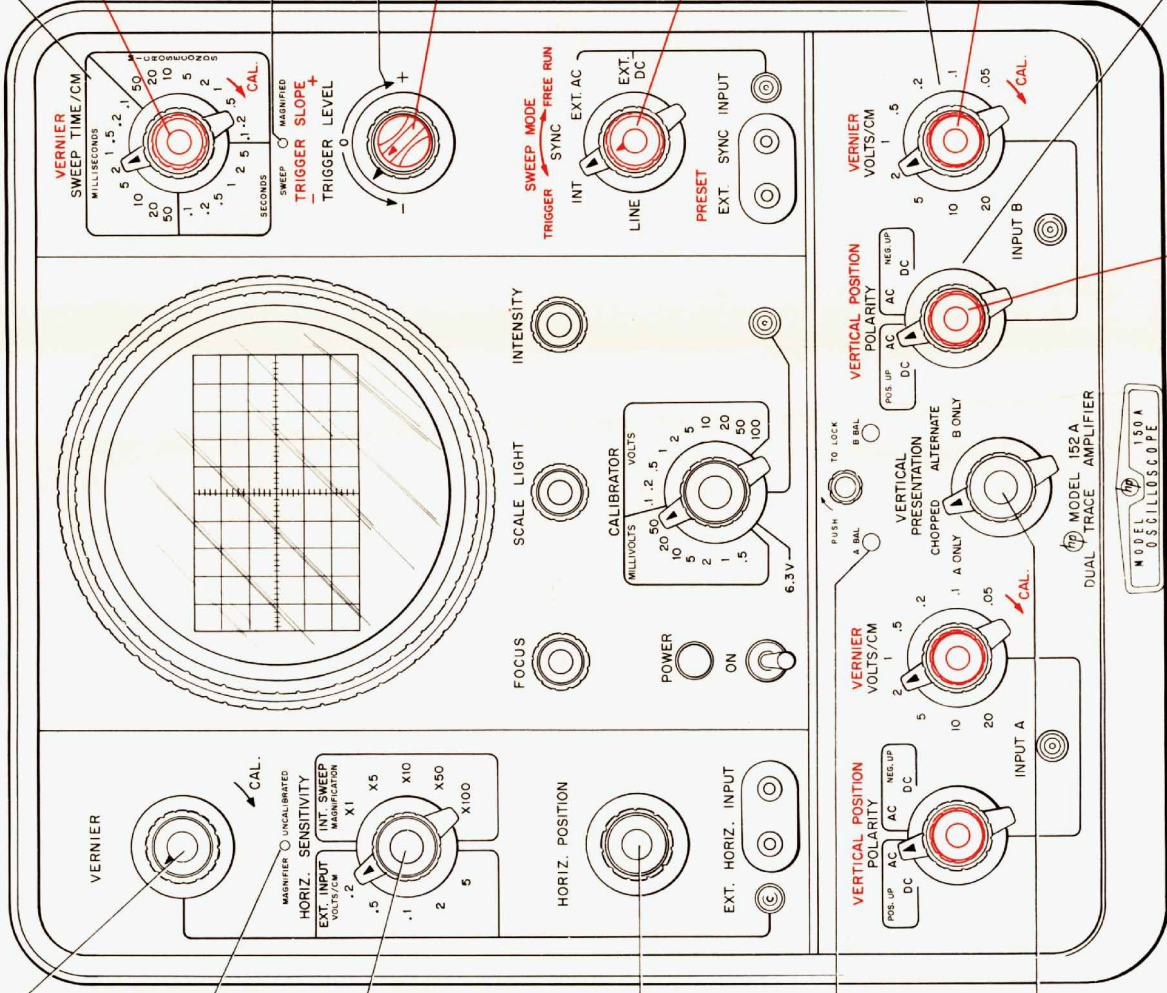



## SECTION II

### OPERATING INSTRUCTIONS

#### 2-1 HIGH VOLTAGE TIME DELAY

The Model 150A applies voltage only to its tube filaments for about 30 seconds after you turn it on. This delay provides an adequate warm up before tube plate voltages and CRT high voltages are applied. If the instrument is turned off for any reason this delay will recycle before the instrument returns to operation.

#### 2-2 CONTROLS AND TERMINALS

The front panel arrangement and operating controls are shown in the fold out illustration, Figure 2-1. The description of the operating controls should enable you to operate the instrument if you have a basic knowledge of oscilloscope technique. However, a complete description of control function follows:

##### 2-2A INTERNAL SWEEP CONTROLS

###### SWEEP TIME/CM

A multi-position switch which selects any one of twenty four calibrated sweep speeds from 0.1  $\mu\text{sec/cm}$  to 5  $\text{sec/cm}$ . This switch is associated with a concentric VERNIER which provides continuous adjustment of sweep speed between steps, and in the full counterclockwise position extends the sweep time to 15  $\text{sec/cm}$ . When the VERNIER is in the full clockwise position (CAL), it is out of the circuit and the sweep time is calibrated within  $\pm 3\%$  as read on the SWEEP TIME/CM dial.

###### INT. SWEEP MAGNIFICATION

A five position magnification control, X1, X5, X10, X50, and X100. The X1 position provides calibrated sweep speeds as read on the SWEEP TIME/CM switch. Other positions indicate degree of expansion taking place about the vertical centerline on the scope graticule. Whenever the sweep is magnified beyond X1 the SWEEP MAGNIFIED lamp will light. The fastest calibrated sweep time of 0.02  $\mu\text{sec/cm}$  is obtained by setting the SWEEP TIME/CM switch to .1 or .2  $\mu\text{sec/cm}$  and setting the

magnifier on X5 or X10 respectively. If you exceed the fastest calibrated sweep time, the MAGNIFIER UNCALIBRATED reminder lamp will light. It will also light with 1  $\mu\text{sec/cm}$  X50 and 2  $\mu\text{sec/cm}$  X100.

###### SYNC

A four position switch which enables the sweep to be triggered either internally or externally. Internal triggering can be accomplished from a line voltage signal or (INT) from an applied vertical input signal of sufficient amplitude to produce a 5mm deflection. External triggering can be effected by signals having amplitudes greater than 0.5 volt. Since the low frequency cut off of the ac coupled sync input circuit is approximately 200 cps, it is advisable to use EXT DC for external low frequency sync signals. Concentric with the SYNC switch is the SWEEP MODE control.

###### SWEEP MODE

A continuous control which adjusts the input bias of the sweep generator. As the control is rotated from the extreme clockwise position, the sweep generator will pass from a free running (FREE) condition to a condition where triggering is required (TRIGGER). At the extreme counterclockwise position the control switches into a PRESET position. PRESET provides optimum triggering bias for nearly all sync applications.

###### TRIGGER LEVEL

A continuous control which selects the amplitude level of the sync signal where triggering occurs. For external synchronizing signals the range of this control is from +30 to -30 volts, allowing the sweep to be triggered at any point within this range on simple or complex waveforms. See Figure 2-2.

###### TRIGGER SLOPE

A two position switch concentric with TRIGGER LEVEL which permits triggering to occur on either the positive or negative slope of internal, external or line voltage sync signals. See Figure 2-2.

###### EXT SYNC INPUT

A pair of binding posts and a BNC connector which are connected in parallel and receive external synchronizing signals.

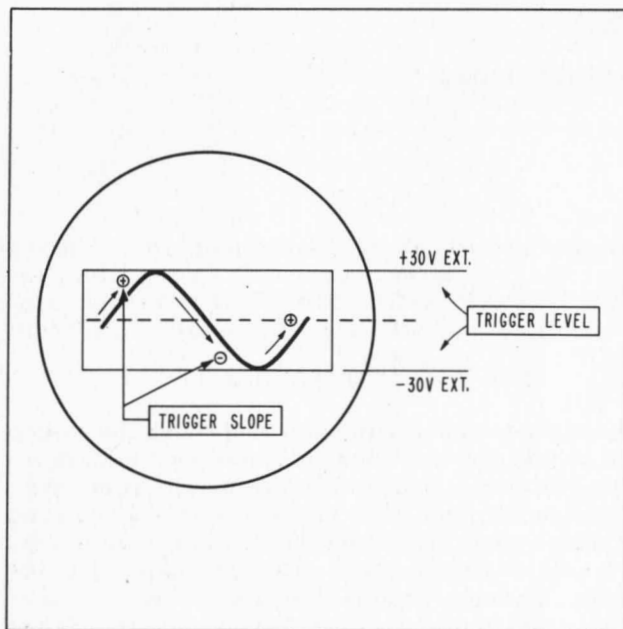

FIGURE 2-2

## 2-2B HORIZONTAL INPUT CONTROLS

### EXT HORIZONTAL INPUT

A pair of binding posts and a BNC connector which are connected in parallel and receive externally applied sweeping signals to drive the horizontal amplifier. The amplifier pass band is from dc to 500 KC.

### EXT INPUT VOLTS/CM

A five position attenuator calibrated from .2 volts/cm to 5 volts/cm which establishes the input sensitivity of the horizontal amplifier. This switch is associated with a concentric VERNIER which provides continuous adjustment between steps and reduces the input sensitivity to 15 volts/cm in the full counter-clockwise position. When the VERNIER is in the full clockwise (CAL) position, it is out of the circuit and the VOLTS/CM switch is calibrated with  $\pm 3\%$ .

### HORIZONTAL POSITION

A multi-turn control which changes the horizontal position of the trace. It covers the range in several turns to let you make fine adjustments under high magnifications of an internal sweep.

## 2-2C DUAL CHANNEL AMPLIFIER CONTROLS

### VERTICAL PRESENTATION

A four position switch which selects the desired vertical channel or desired dual channel presentation. This switch is labeled;

- A ONLY**      The output of the A channel is applied to the vertical amplifier.
- B ONLY**      The output of the B channel is applied to the vertical amplifier.
- ALTERNATE**    The two channels are alternated at the sweep rate. See paragraph 2-5.
- CHOPPED**      The two channels are switched at a free running rate of 100 KC. The two traces are each composed of five microsecond segments spaced five microseconds apart. See paragraph 2-5.

### POLARITY

A four position switch which allows the input signal polarity to be displayed either up or down on the scope, and which selects either AC or DC coupling. One for each channel.

### VERTICAL POSITION

A continuously adjustable control, concentric with POLARITY, which adjusts the vertical position of the input signal. One for each channel.

### VOLTS/CM

A nine step attenuator which selects the input sensitivity of the vertical amplifier. Sensitivities range from .05 volts/cm to 20 volts/cm in a 5-1-2 sequence. When the concentric VERNIER is in the CAL position the VOLTS/CM attenuator is calibrated within  $\pm 3\%$ . One for each channel.

### A-BAL and B-BAL

Screwdriver adjustments for adjusting the dc balance of each vertical amplifier. See Figure 2-11.

### A-CAL and B-CAL

Screwdriver adjustments for setting the gain of each vertical amplifier.

## 2-2D CRT PANEL CONTROLS

### FOCUS

Controls trace resolution.

### INTENSITY

Controls trace brightness.

### SCALE LIGHT

Adjusts brightness of graticule lines.

### CALIBRATOR

A multi-position switch which adjusts a 1000 cps square wave from 0.2 millivolts to 100 volts in a 2-5-10 sequence with an accuracy of  $\pm 3\%$ . The output voltage appears at the adjacent terminal and can be used to calibrate the deflection sensitivity of the vertical and horizontal amplifier. Square wave rise and decay times are each less than 1 microsecond. The square wave output may also be used to adjust the divider probe for frequency response.

## 2-2E TOP ACCESS CONTROLS

The following controls and terminals are accessible through the top access door of the instrument cabinet.

Horizontal and vertical deflection plates.

A terminal for CRT intensity (Z-axis) modulation

### SAWTOOTH OUT

A terminal which provides a sawtooth output voltage corresponding to the sweep.

### GATE OUT

A terminal which provides a positive gate voltage for the duration of the sweep.

### SINGLE-NORMAL

A switch which selects either normal or single sweep operation. In single sweep position the circuits are arranged to sweep once after a trigger signal and then remain inoperative until manually or electronically reset. The ARMED lamp lights when the single sweep circuit is ready for a trigger.

### RESET

A terminal which can receive an external pulse to rearm the single sweep circuit. Pulse characteristics required = +15 to +25 volts peak with no overshoot; 2 to 4  $\mu$ seconds width.

### FUSE

Line fuse (F1) 6-1/4 amp slo-blo.

Thermal cutout with resetting button.

## 2-3 OPERATING PROCEDURES

Basic operating procedures are described by illustrations which are keyed to procedural steps in each case. The first two procedures are complete. Others are arranged to supplement the first two by showing the variations possible in using the oscilloscope. An index to these illustrations follows:

### FIG.

### TITLE

2-3	Internal Sweep -- Internal Sync
2-4	Internal Sweep -- External Sync
2-5	Internal Sweep Magnification
2-6	External Horizontal Input
2-7	Vertical Input -- Dual Trace
2-8	Adjusting Divider Probe
2-9	Removing CRT Bezel
2-10	Aligning Scope Trace with Graticule
2-11	Vertical Balance Adjustment
2-12	Direct Connection to CRT Plates
2-13	Capacitive Coupling to CRT Plates
2-14	Single Sweep Operation
2-15	Delayed Sweep Operation
2-16	Vertical VOLTS/CM Calibration
2-17	External Intensity Modulation

## 2-4 VERTICAL AC OR DC COUPLING

Under most conditions AC coupling will be used. It permits high gain to be employed without regard for the dc levels involved. In the AC position the input signal (vertical or external sync) is coupled to the instrument through a capacitor which removes the dc component from the input wave. This coupling circuit has a low frequency cut off at 2 cps; however, to avoid degrading input pulses or square waves below 10 cps it is advisable to use dc coupling.

When you want to look at waveforms relative to a dc level; for example, observing a Miller rundown in circuit work, or in mechanical work where the output from a transducer has a dc component; use dc coupling.

## **2-5 USE OF CHOPPED OR ALTERNATE SWEEP**

CHOPPED and ALTERNATE VERTICAL PRESENTATION are used to present two separate electrical phenomena, which are related in frequency or rate of recurrence, to the oscilloscope CRT for simultaneous viewing. ALTERNATE may be used whenever sweep time and rate of recurrence are rapid enough and screen persistence is long enough to prevent objectionable flicker. CHOPPED PRESENTATION should be used if, in the ALTERNATE position a flickering effect is noticeable on the screen as the inputs are switched after

each sweep. When two related signals are being presented to the oscilloscope for simultaneous viewing using either CHOPPED or ALTERNATE VERTICAL PRESENTATION the 150A should be synchronized externally.

In some cases it may be desirable to view two different input waves not related in frequency. In this instance the 150A may be synchronized internally, triggering automatically first from one signal then from the other. This procedure is not ordinarily recommended since it may cause noticeable deterioration of the quality of the presentation. Quality generally may be improved by adjusting the VERTICAL POSITION controls so that the traces overlap.

## INTERNAL SWEEP — INTERNAL SYNCHRONIZATION

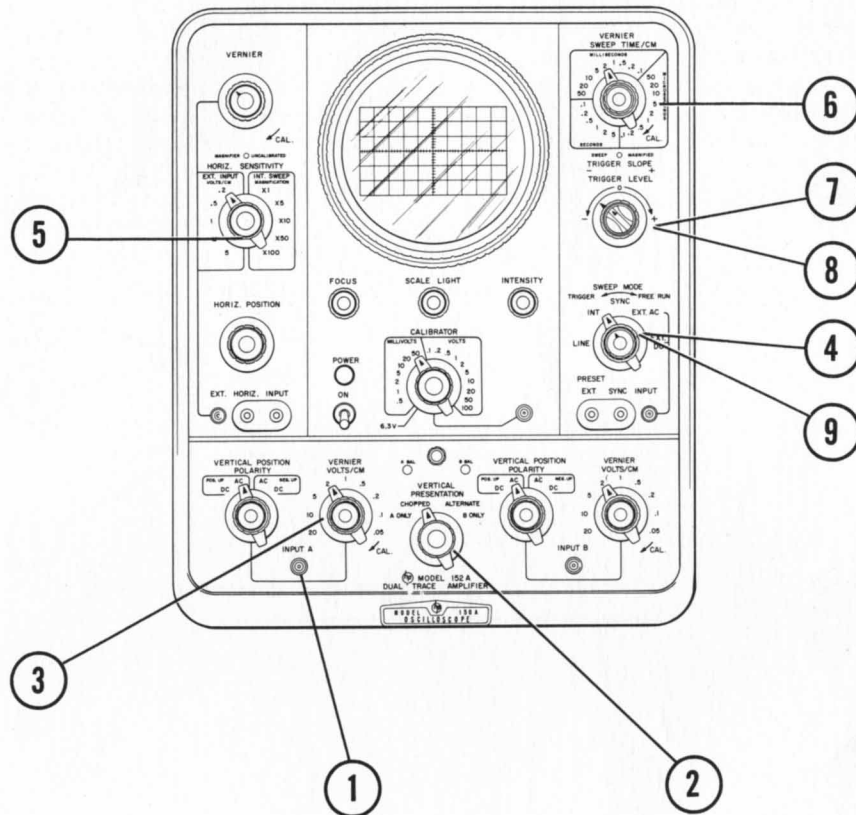

1. Place vertical input signal into plug-in amplifier.
2. If dual trace amplifier is used, set VERTICAL PRESENTATION selector to A or B input; assume one input is used.
3. Adjust VOLTS/CM selector for desired sensitivity.
4. Set SYNC selector to INT.
5. Set HORIZONTAL SENSITIVITY to INT SWEEP: X1.
6. Select desired sweep speed.
7. Set TRIGGER LEVEL to zero.
8. Set TRIGGER SLOPE for triggering on positive or negative slope of input wave as desired.
9. Set SWEEP MODE to PRESET.

FIGURE 2-3

## INTERNAL SWEEP — EXTERNAL SYNCHRONIZATION

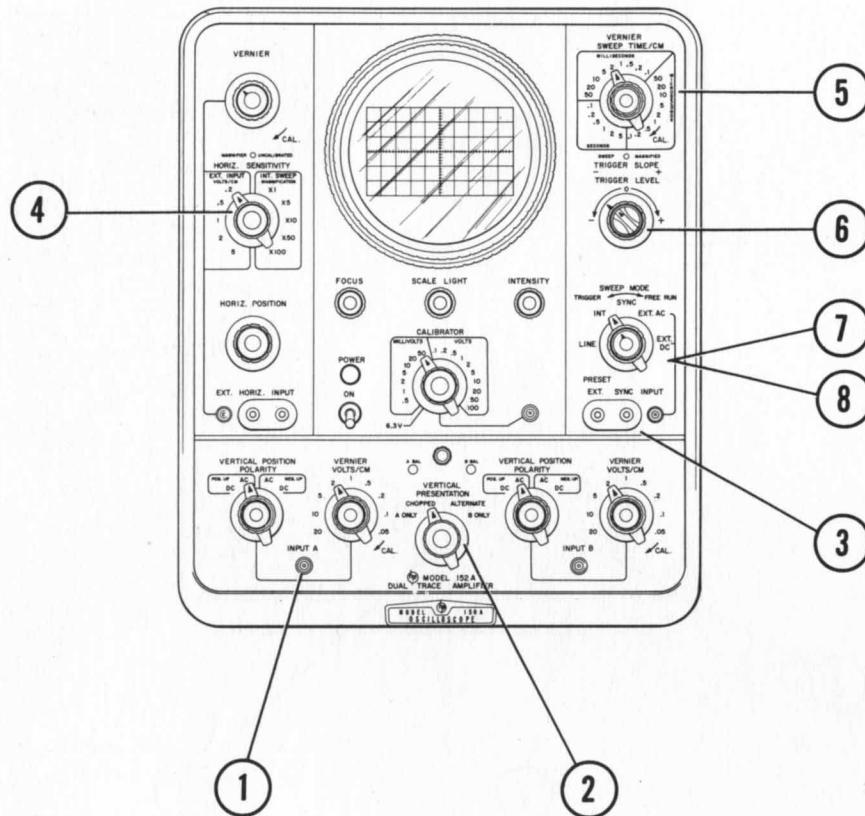

1. Place vertical input signal into plug-in amplifier.
2. If dual trace amplifier is used, set VERTICAL PRESENTATION switch to proper input. Assume one input is used (A or B).
3. Place sync signal into EXT SYNC INPUT terminals.
4. Place HORIZ SENSITIVITY to INT SWEEP X1.
5. Select desired sweep speed with SWEEP TIME/CM switch.
6. Set TRIGGER LEVEL to zero.
7. Adjust SYNC selector to AC or DC as required (see paragraph 2-4).
8. Place SWEEP MODE in PRESET.

FIGURE 2-4

## INTERNAL SWEEP MAGNIFICATION

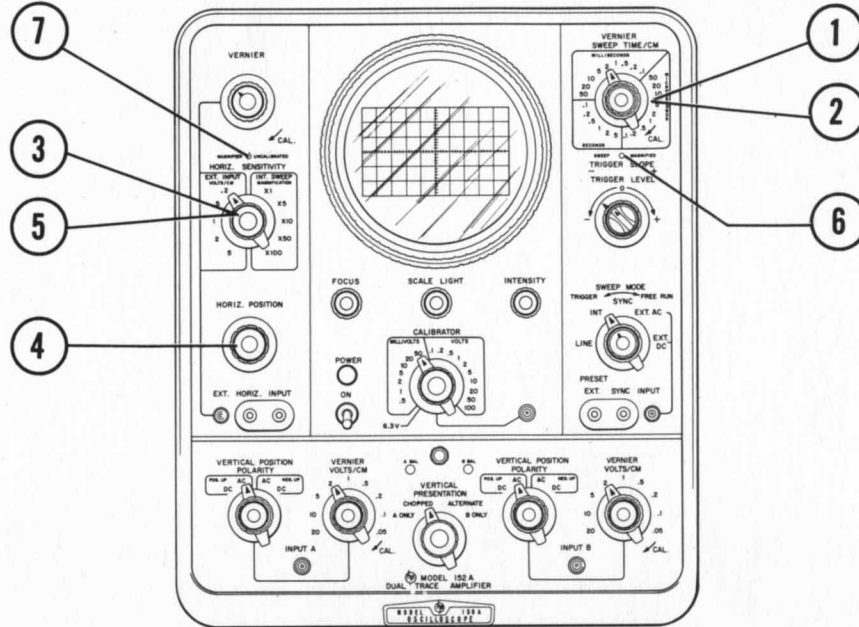

1. Select sweep speed with SWEEP TIME/CM switch.
2. Place VERNIER in CAL when direct reading of SWEEP TIME/CM switch is desired.
3. Set HORIZ SENSITIVITY to INT SWEEP X1 (X1 is the unmagnified sweep position).
4. Adjust horizontal position of trace. If you want to magnify a portion of a wave or a particular wave in a train, place wave of interest under vertical graticule center line with HORIZ POSITION control.
5. Switch HORIZ SENSITIVITY to desired magnification (X5 or above).
6. SWEEP MAGNIFIED indicator will light.
7. If combination of sweep speed and degree of magnification exceeds maximum calibrated sweep speed (.02  $\mu$ seconds/cm) the MAGNIFIER UNCALIBRATED indicator will light.

### EXAMPLE

$$\text{SWEEP TIME/CM} = .5 \mu\text{sec/CM}$$

$$\text{MAGNIFICATION} = X50$$

Actual sweep time/cm =  $.5 \mu\text{sec/cm} \div X50 = .01 \mu\text{sec/cm}$ ; uncalibrated lamp will light. Increase sweep time or reduce degree of magnification.

$$\text{SWEEP TIME/CM} = .5 \mu\text{sec/CM}$$

$$\text{MAGNIFICATION} = X10$$

$$\text{Actual Sweep Time} = .5 \mu\text{sec/CM} \div (X10) = .05 \mu\text{sec/CM}$$

(Sweep time > .02  $\mu\text{sec/CM}$ , MAGNIFIER UNCAL lamp stays off)

FIGURE 2-5

## EXTERNAL HORIZONTAL INPUT

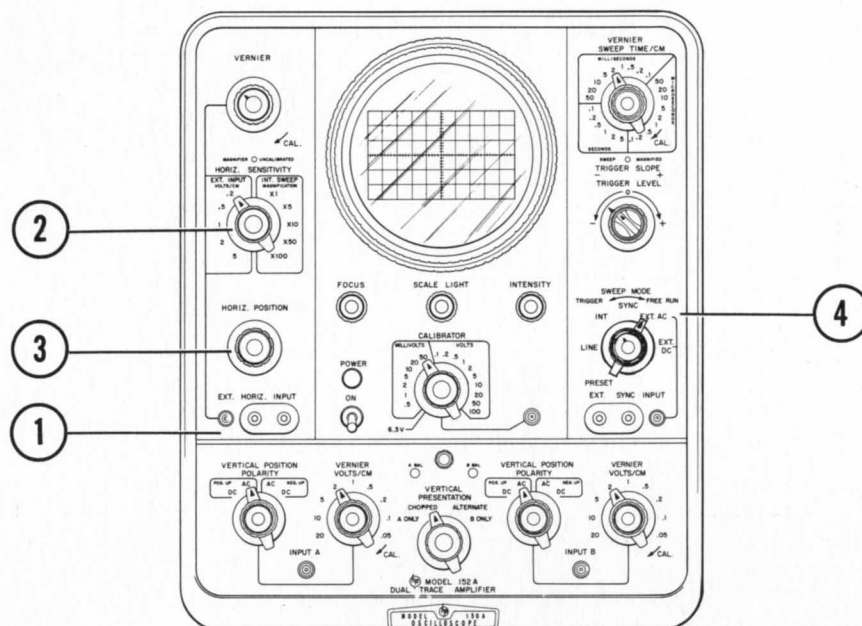

1. Insert external horizontal signal.
2. Select desired sensitivity on EXT INPUT side of HORIZONTAL SENSITIVITY control.
3. Adjust horizontal position.
4. Turn SYNC selector to an EXT position.
5. For vertical input see Figures 2-3 and 2-4.

FIGURE 2-6



## VERTICAL INPUT — DUAL TRACE

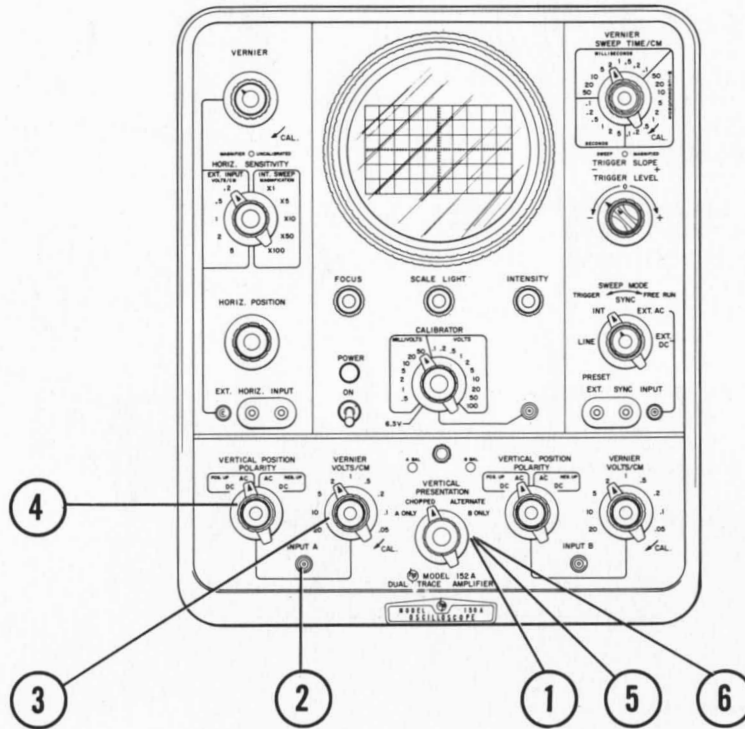

1. Set to A only. Adjust vertical position of trace near upper (or lower) portion of scope face.
2. Place one of two input signals into INPUT A.
3. Adjust deflection sensitivity with VOLTS/CM switch. When VERNIER reads CAL, accuracy of VOLTS/CM switch is  $\pm 3\%$ .
4. Select polarity of presentation. (Whether negative or positive portion of input wave is displayed up or down.)
5. Switch to INPUT B and repeat above procedure on B side of panel.
6. Switch to ALTERNATE or CHOPPED for dual trace presentation. (See paragraph 2-5.)

FIGURE 2-7

## ADJUSTING AC-21 LOW-CAPACITY PROBE

1. Connect the AC-21A Probe to the desired vertical input, and set the VERTICAL PRESENTATION selector to the corresponding input.
2. Set the CALIBRATOR selector to 2. Set the vertical VOLTS/CM selector to .05.
3. Set the SWEEP TIME/CM selector to .5 MILLISECOND/CM; set the SYNC selector to INT, the SYNC control to PRESET.
4. Touch the probe to the CALIBRATOR connector and observe the 1-kc square wave.
5. Loosen probe locknut by unscrewing.
6. Tune probe to obtain flattest top on square wave by turning rear flange on probe.
7. Tighten locknut to retain adjustment.

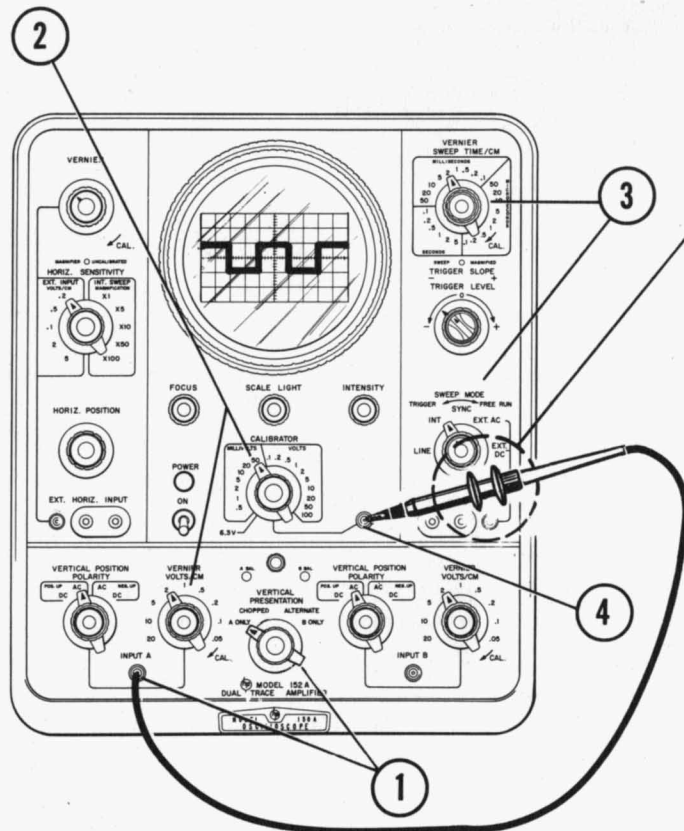
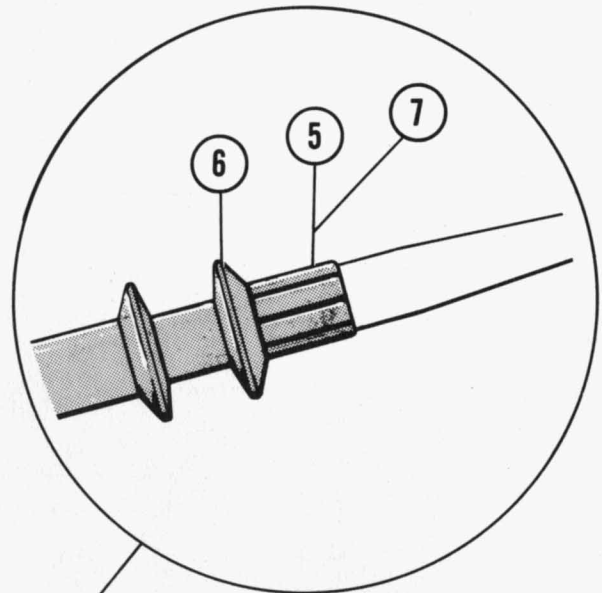
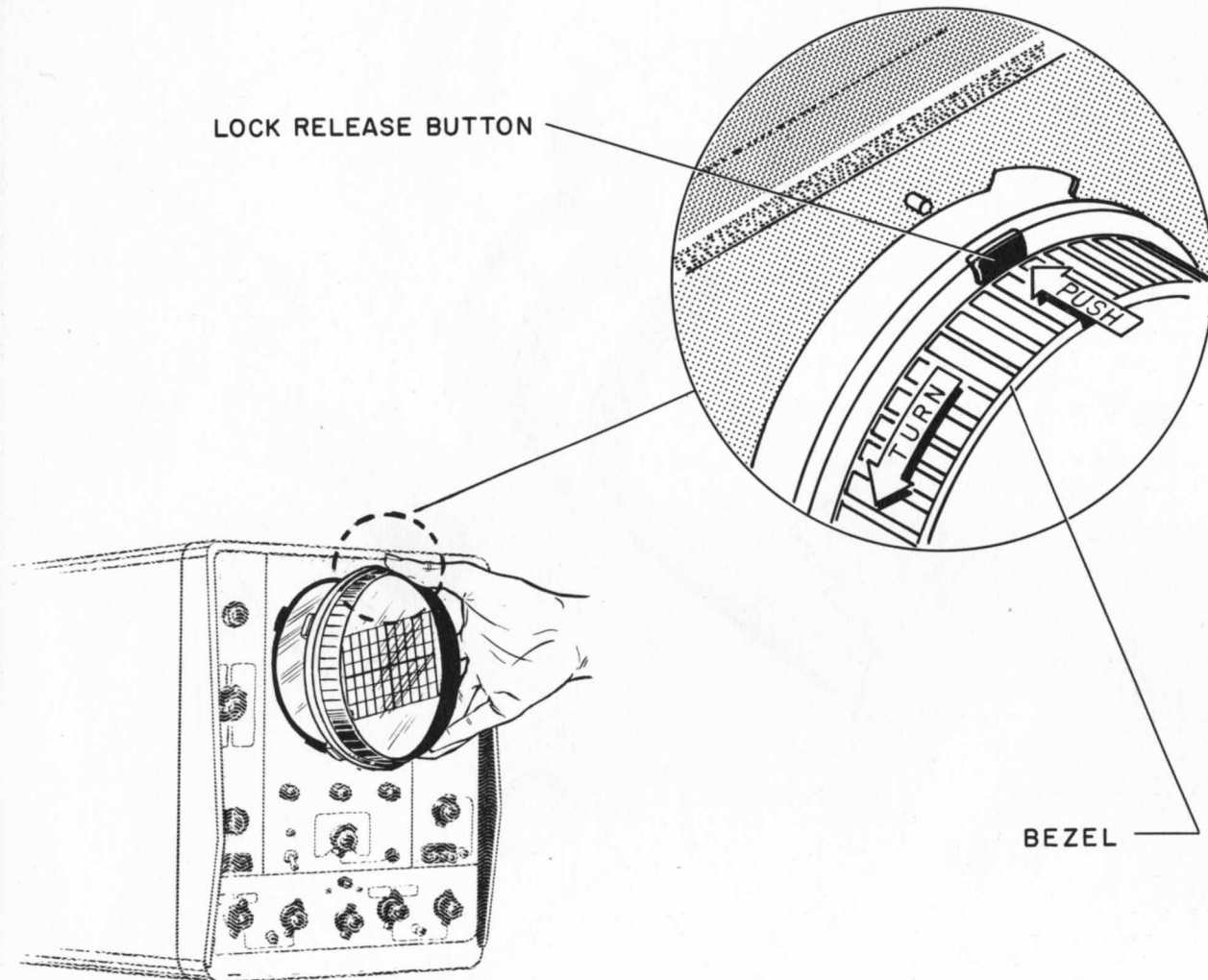

FIGURE 2-8

## REMOVING CRT BEZEL



The CRT bezel contains the filter and graticule shields; it has also been designed to accept oscilloscope camera equipment without adapters of any kind. To change filters or cathode ray tubes the bezel must be removed.

To remove bezel:

1. Depress lock release button, and twist bezel counter clockwise about 15 degrees.
2. Pull bezel straight from panel as shown.

FIGURE 2-9

## ALIGNING SCOPE TRACE WITH GRATICULE

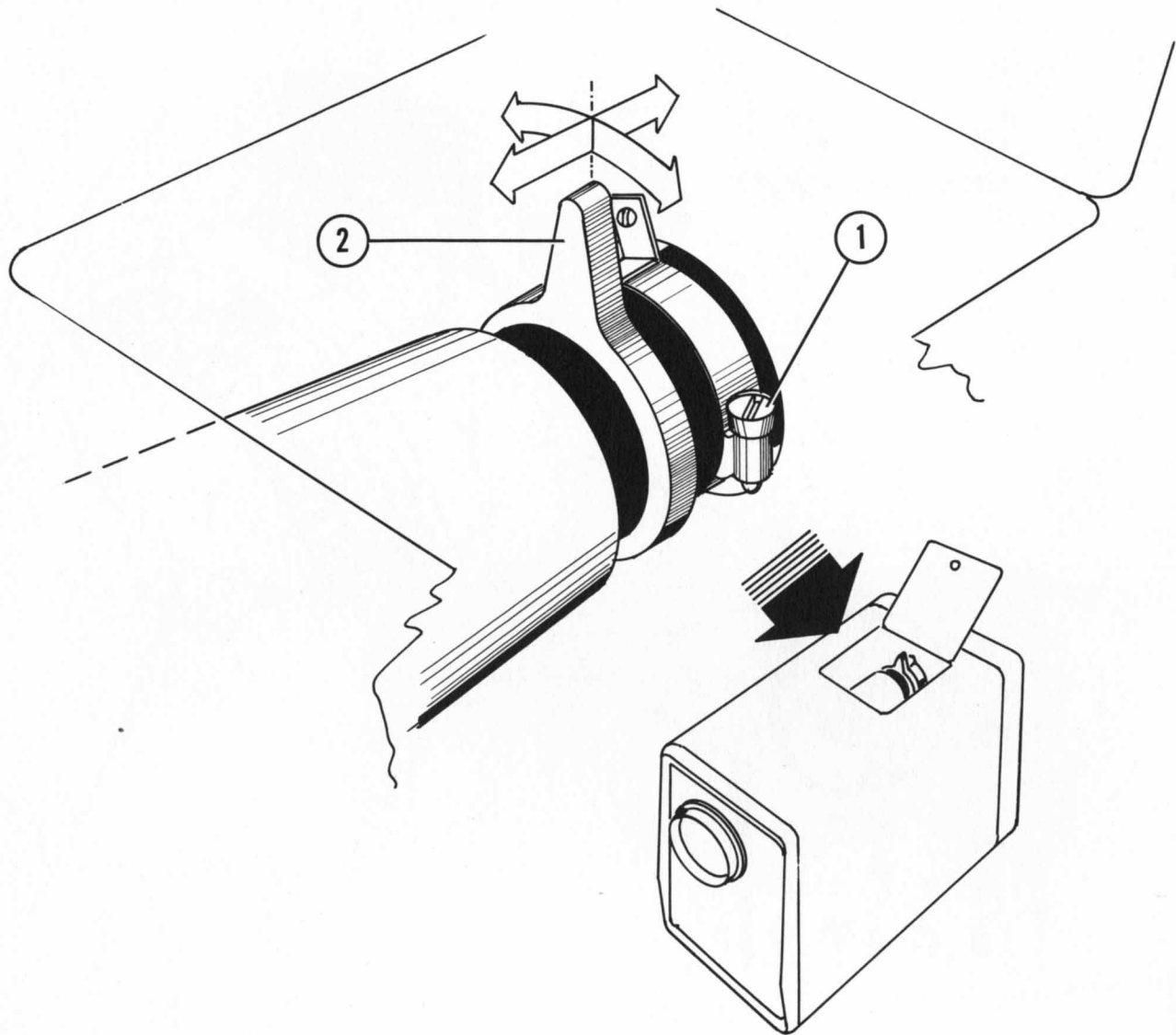

Alignment of CRT with graticule may be accomplished through access hatch without removing instrument from case.

Fiber lever (2) controls both radial and longitudinal positioning of CRT and is locked by clamp (1), using screwdriver.

FIGURE 2-10

## VERTICAL BALANCE ADJUSTMENT

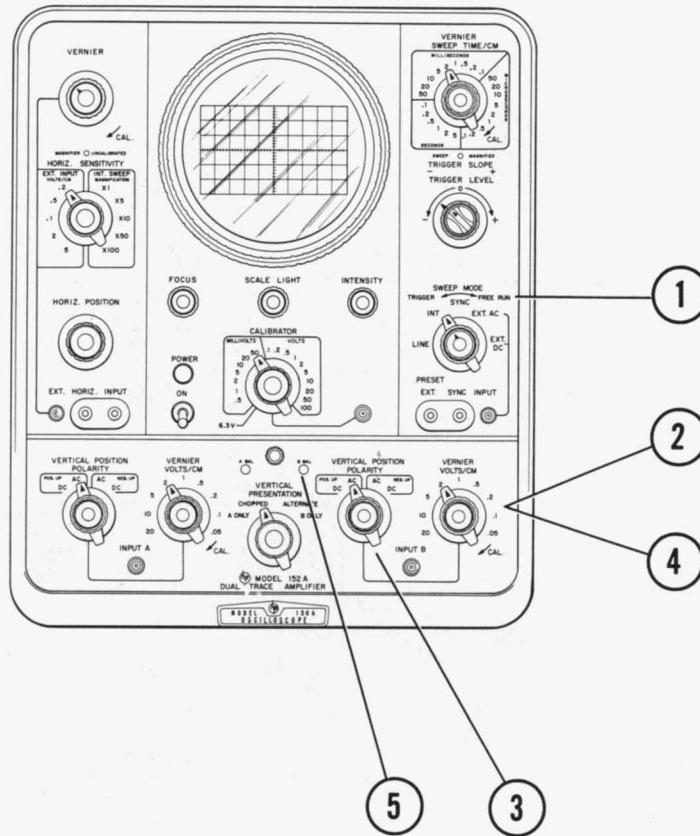

Procedure given for B channel, but is same for A channel.

1. Set SWEEP MODE control to FREE RUN.
2. Set VERNIER to minimum (full counter clockwise).

3. Center trace with VERTICAL POSITION control.

4. Switch VERNIER to CAL (full clockwise).

5. Adjust B-BAL control to return trace to center of scope.

Repeat steps 2 to 5 until trace remains centered.

FIGURE 2-11

## DIRECT CONNECTION TO DEFLECTION PLATES

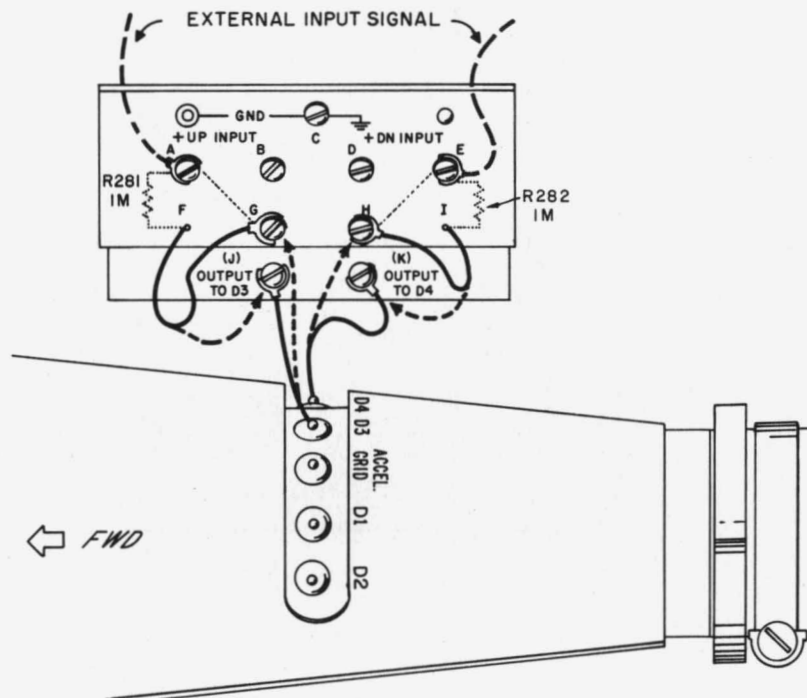

**CAUTION** - The deflection plates of the oscilloscope operate at a d-c potential of approximately +250 volts. Therefore there can be no common chassis connection between the signal source and the oscilloscope. In most cases the signal source chassis will assume the deflection plate potential. Turn off the instrument before making connection to deflection plate terminals.

To connect an external signal directly to vertical deflection plates:

### A. Balanced Input

1. Connect signal to terminals A and E.

2. Relocate leads from F, I, D3 and D4 as shown by dashed lines.

### B. Single-Ended Input

1. Connect the signal to A for + up deflection (to E for + down deflection).
2. Connect an appropriate bypass capacitor between C and E for + up deflection (between C and A for + down deflection). Signal source return connects to E or A, whichever is bypassed.
3. Relocate leads from F, I, D3 and D4 as shown by dashed lines.

FIGURE 2-12

## CAPACITIVE CONNECTION TO DEFLECTION PLATES

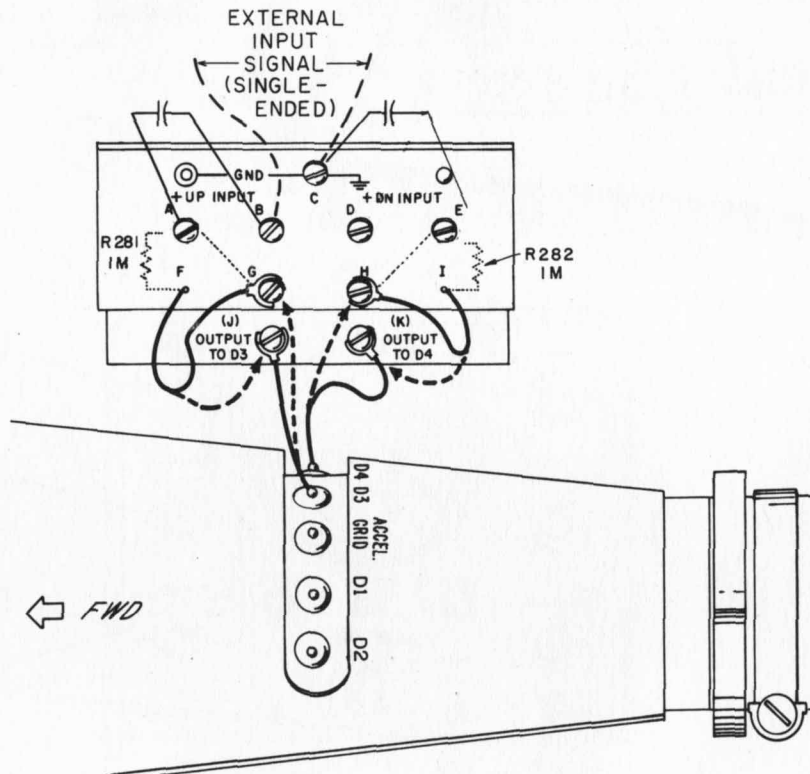

**CAUTION** - Turn off instrument before making connection to deflection plate terminals.

To ac couple a signal to the vertical deflection plate:

### A. Single-Ended Input

1. Connect external signal to B for + up deflection (to D for + down deflection) and the signal return to C.
2. Connect an appropriate bypass capacitor between C and E for + up deflection (between C and A for + down deflection).
3. Connect an appropriate d-c blocking

capacitor between A and B for + up deflection (between D and E for + down deflection).

### B. Balanced Input

1. Connect external balanced signal to terminals B and D.
2. Connect appropriate d-c blocking capacitors between terminals A and B and between terminals D and E.
3. Relocate leads from F, I, D3, and D4 as shown by dashed lines.

FIGURE 2-13

## SINGLE SWEEP OPERATION

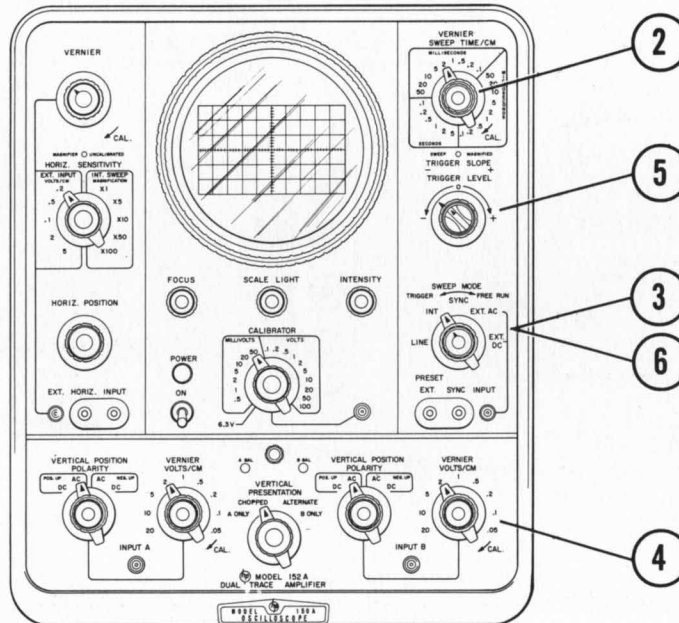
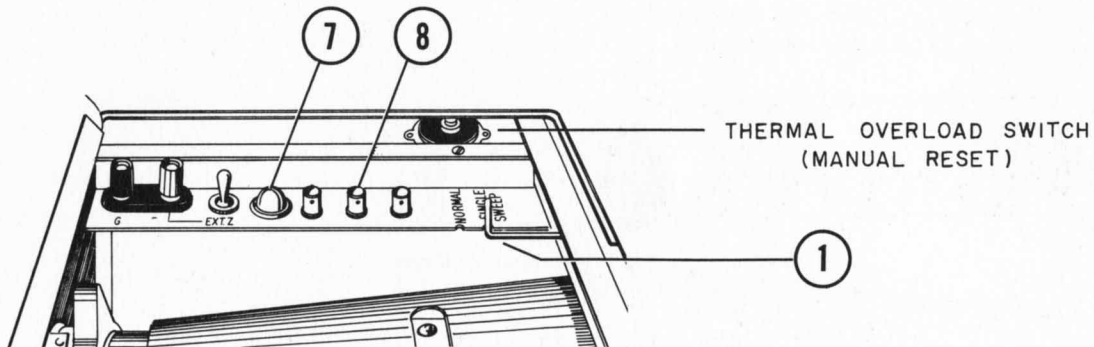

1. Set selector inside top access to SINGLE.
2. Select sweep speed.
3. Set SYNC switch to INT. and SWEEP MODE to PRESET.
4. Select desired vertical sensitivity.
5. Adjust TRIGGER LEVEL to ZERO and SLOPE as desired. (In some applications it may be convenient to establish desired TRIGGER LEVEL in NORMAL operation.)
6. Switch SWEEP MODE control out of PRESET and back to PRESET to arm sweep circuit.
7. Indicator should light as soon as SWEEP MODE control is returned to PRESET. When input signal is received, sweep will fire once, indicator (7) will extinguish, and sweep will remain locked out until reset as described in step 6., or
8. Resetting can be accomplished by placing 1-4  $\mu$ sec width, +15 to +25 volt peak pulse into RESET terminal.

FIGURE 2-14



## DELAYED SWEEP OPERATION

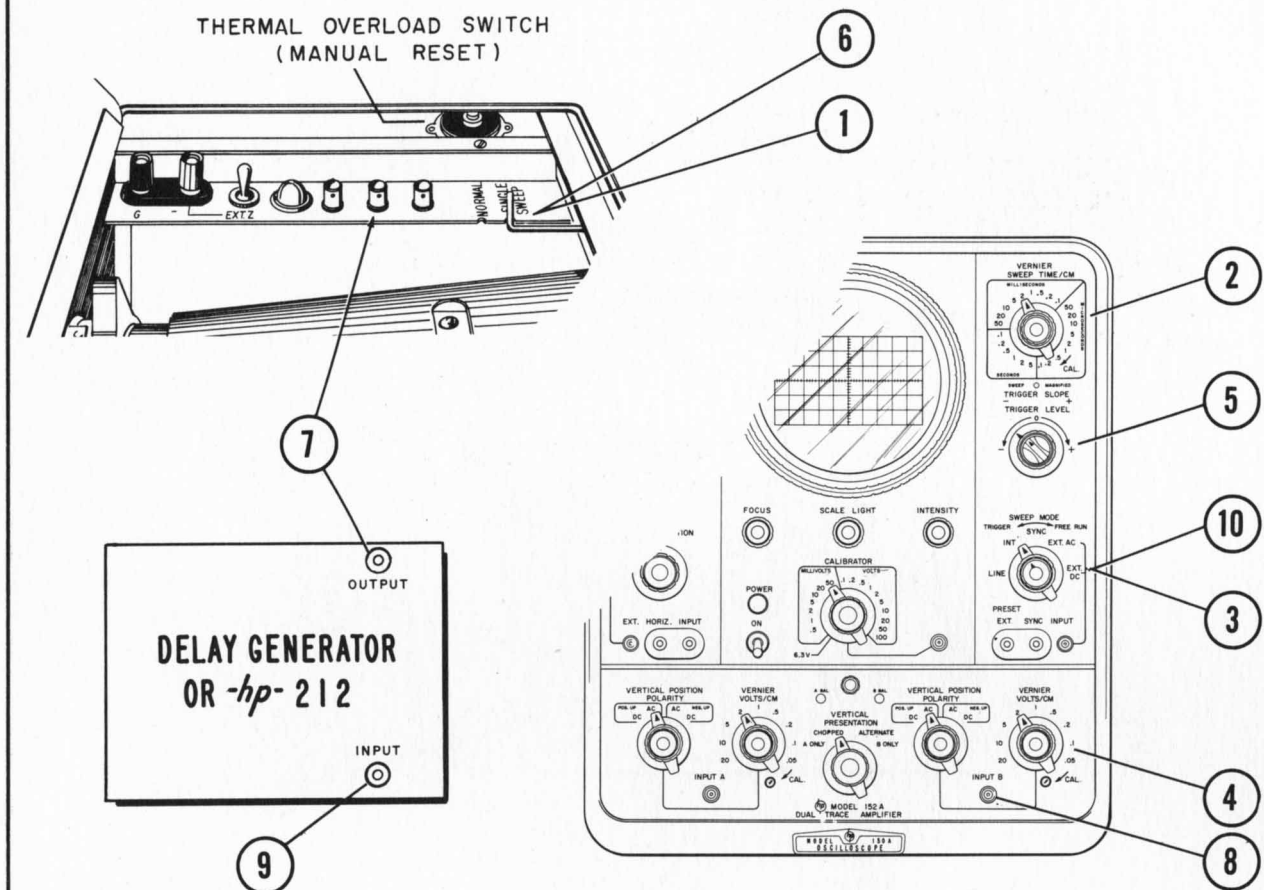

1. Set selector inside top access to NORMAL.
2. Select sweep speed.
3. Set SYNC switch to INT and SWEEP MODE to PRESET.
4. Select desired vertical sensitivity.
5. Adjust TRIGGER LEVEL and SLOPE for desired triggering.
6. Switch selector to SINGLE.
7. Connect output of DELAY GENERATOR to RESET terminal inside top access.
8. Connect signal to be observed to scope input. (Channel A or B as desired.)
9. Connect trigger source to input of delay generator. Trigger-source signal in some applications may be same as signal to be observed (step 8) or it may be some other signal. This signal serves as a single sweep retriggering source. (See SINGLE SWEEP OPERATION.)
10. It may be desired to have the sweep start immediately at end of delay period instead of awaiting the arrival of signal to be observed. To accomplish this, follow steps 1 through 9, except that after step 6, set SWEEP MODE control to FREE RUN.

FIGURE 2-15

## VERTICAL VOLTS/CM CALIBRATION

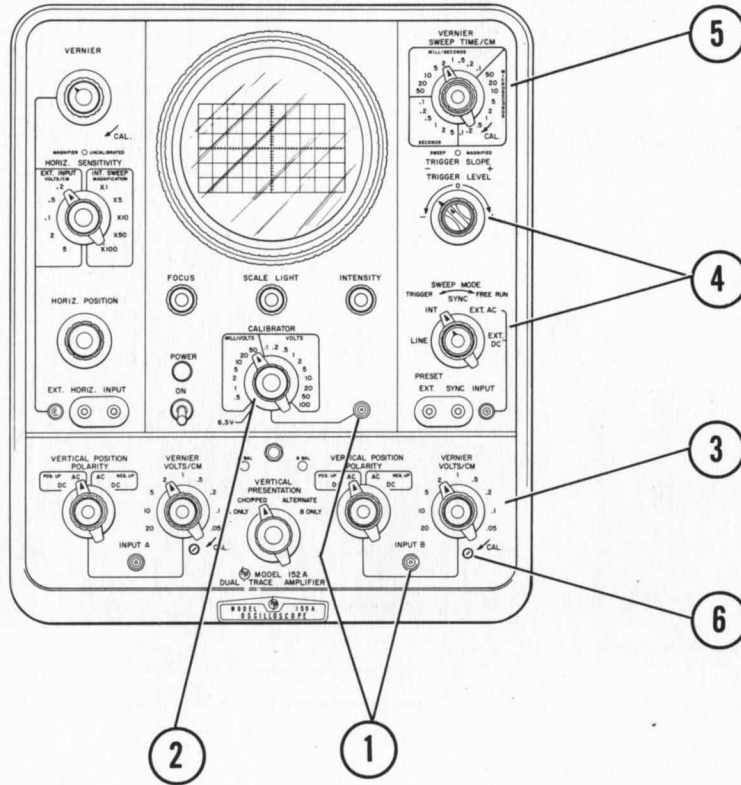

This procedure assumes that vertical balance adjustments (Figure 2-11) have been made.

1. Connect CALIBRATOR output (or any accurate ac voltage) to the vertical INPUT (assume B in this case).
2. Set CALIBRATOR to the .2 volt position (use 2 volt position if AC-21A probe is used).
3. Set VOLTS/CM switch to .05, and switch

VERNIER to CAL.

4. Sync scope internally.
  5. Use convenient sweep speed (app. .5 MS/CM).
  6. Adjust R589 (accessible through front panel as shown) to obtain a vertical deflection of exactly 4 centimeters on scope graticule.
- Repeat procedure for channel A.

FIGURE 2-16

## EXTERNAL INTENSITY MODULATION

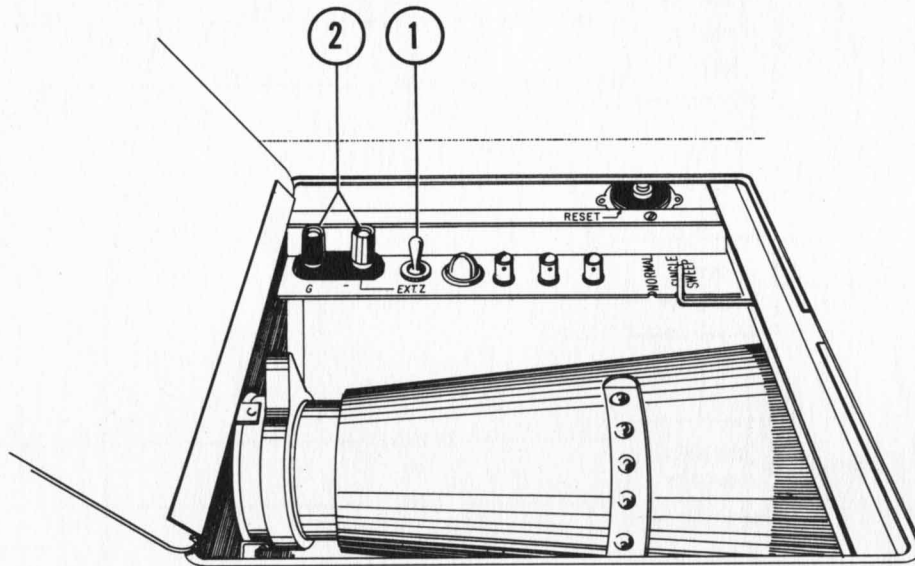

To intensity modulate the CRT with external signals:

1. Set INT. Z - EXT. Z switch to EXT. Z.
2. Connect modulating signal to input terminals. A positive voltage of 20 volts peak will blank the CRT trace from normal intensity. A negative input will brighten the trace.

FIGURE 2-17

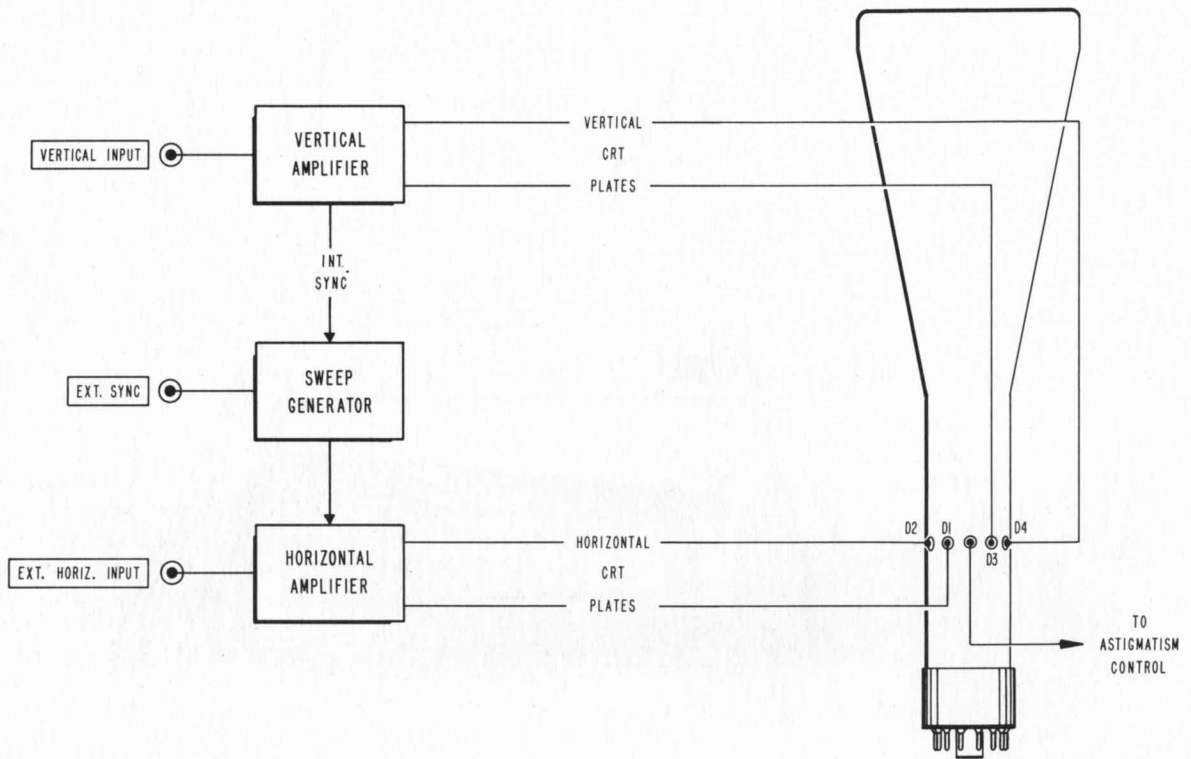

FIGURE 3-1

## SECTION III

### THEORY OF OPERATION

#### 3-1 GENERAL CONTENT

This section contains a brief description of the overall operation of the 150A Oscilloscope, descriptions of each major section and detailed explanations of the Feedback Integrator Sawtooth Generator and Schmitt Trigger. The description for each major section is supported by its complete schematic diagram, voltage - resistance-tube-location diagram, and when necessary, a switch detail diagram, at the rear of the manual. The material in this section is as follows:

- 3-2 Overall Operation and Circuit Locations
- 3-3 Synchronizing Circuit
- 3-4 Sweep Generator
- 3-5 Feedback Integrator and Diode Switch
- 3-6 Schmitt Trigger Circuits
- 3-7 Horizontal Amplifier
- 3-8 Main Vertical Amplifier
- 3-9 Model 152A Dual Trace Amplifier Plug-In Unit
- 3-10 Calibrator
- 3-11 Regulated Low-Voltage Power Supply
- 3-12 Regulated High-Voltage Power Supply
- 3-13 Single Sweep And Delayed Sweep Operation

#### 3-2 OVERALL OPERATION

The simplified block diagram in Figure 3-1 shows the basic signal circuits in the Model 150A Oscilloscope: the Vertical Amplifier, Horizontal Amplifier, Sweep Generator and Cathode Ray Tube.

a. Vertical Amplifier - The vertical amplifier receives the input signal, amplifies it, and drives the vertical deflection plates. It provides attenuation of the input signal; determines the direction of spot deflection for a given input signal polarity; determines the vertical position of the spot on the screen; supplies a signal for internal synchronization; and incorporates a 0.25  $\mu$ sec delay in the input waveform.

The complete Vertical Amplifier circuit is in three separate parts: the final amplifiers, located on the upper board; the intermediate amplifiers on the lower board on the instrument chassis, as shown in Figure 3-2, the input-preamplifier attenuators, phase inverters and beam positioners are on the etched board in the Vertical Amplifier Plug-In Unit. All connections to the plug-in unit are made through two multiple-contact connectors as the plug-in is pushed into position. Power connections to the Main Vertical Amplifier on the instrument chassis are made through a tube-socket connector, while the signal path between the intermediate and power amplifier stages is made through the special coaxial-cable delay lines.

b. Horizontal Amplifier - The horizontal amplifier receives the sweep voltage either from the HORIZONTAL INPUT jack or from the internal sweep generator, amplifies it, and drives the horizontal deflection plates. It provides attenuation of the HORIZONTAL INPUT signal or MAGNIFICATION of the internal sweep and determines the horizontal position of the spot on the screen.

The complete Horizontal Amplifier consists of the main Amplifier, and a preamplifier (used only for external signals applied to the HORIZONTAL INPUT connector). The preamplifier stage includes the VOLTS/CM portion of the HORIZONTAL SENSITIVITY selector switch and is not effective when the switch is set to one of the MAGNIFICATION positions. The MAGNIFICATION circuit of the HORIZONTAL SENSITIVITY selector is in the Main Horizontal Amplifier. The sawtooth sweep is applied to the Main Horizontal Amplifier while external signals are first fed through the HORIZONTAL SENSITIVITY switch and the preamplifier.

The complete Horizontal Amplifier circuit is located on the single etched board on the left-hand, swing-out chassis. Connections to the chassis are made through two tube-socket connectors on the board.

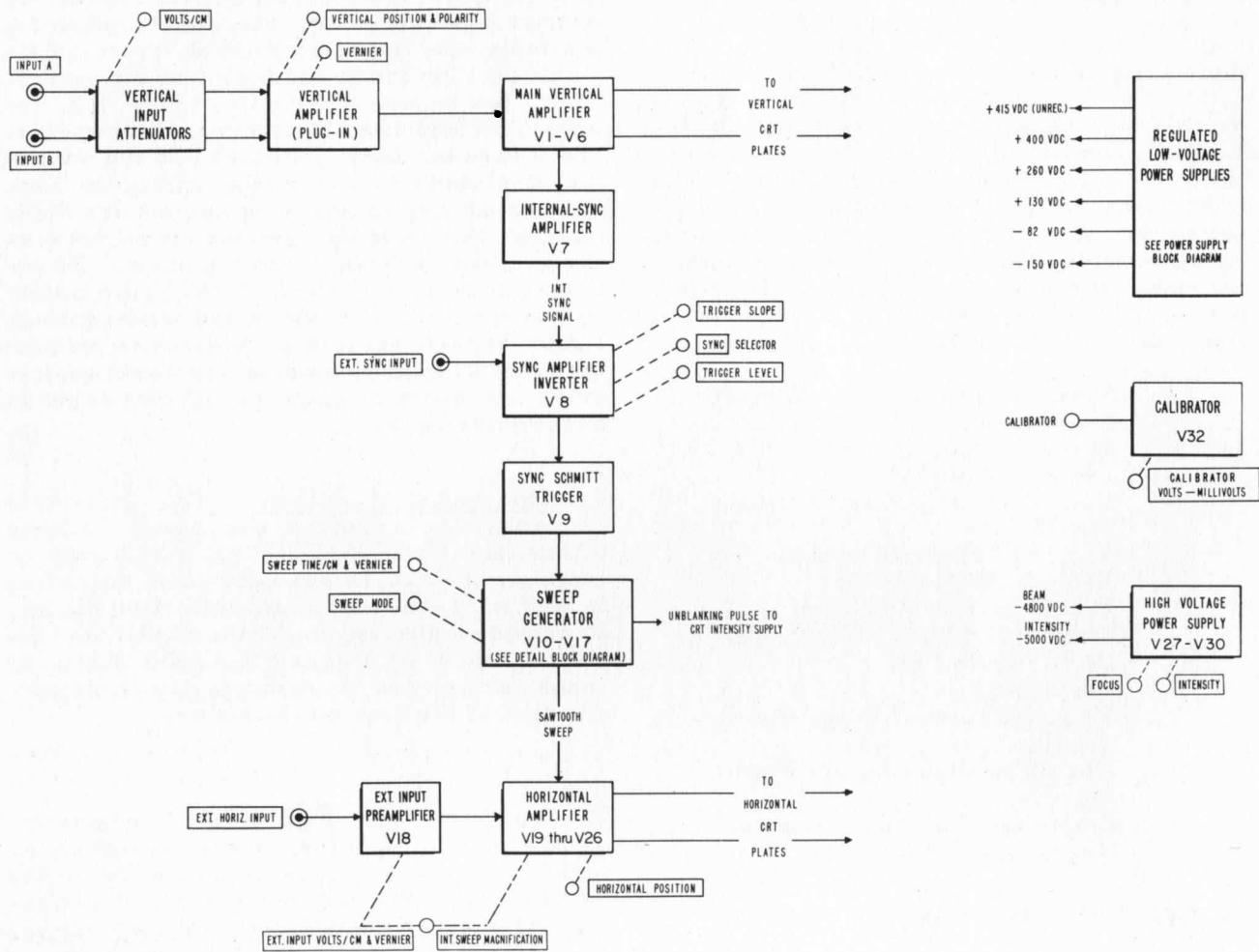

FIGURE 3-2

c. Sync Circuit - The Synchronizing Circuit receives a sync signal either from the Vertical Amplifier for internal synchronization; from the EXT. SYNC INPUT connector for external synchronization, or from an internal 6.3-volt source for line frequency synchronization. The Sync Circuit amplifies all input signals, determines the input voltage level and polarity of input sync signal which will start a sweep; and supplies a fast and reliable sync pulse for operation of the Sawtooth Generator.

d. Sweep Generator - The Sweep Generator receives a negative starting pulse from the Sync Circuit and generates a sawtooth to be fed to the Horizontal Amplifier. The Feedback Integrator determines the basic sweep time per centimeter, the Retriggering Bias Control determines the sensitivity of the generator to incoming sync signals and provides either single or repetitive sweeps. The sweep generator also supplies an unblanking pulse to the CRT and a timing signal (during each sawtooth flyback) to the Dual Channel Vertical Amplifier Plug-In Unit for ALTERNATE operation.

The complete Sweep Generator and Sync Circuit is located on the single etched board on the right-hand, swing-out chassis. All connections to this chassis are made through three tube-socket connectors and three pin connectors on the board.

e. The CRT - The CRT is a type 5AMP, a mono-accelerator tube with the cathode operated at -5000 volts. The 5AMP may be obtained with four different phosphors: 1, green medium; 2, green long; (normally supplied with the 150A) 7, blue long; the 11, blue short. All are interchangeable with little readjustment and the tube is easily changed through the front panel. The mono-accelerator anode makes possible a simple astigmatism adjustment (located inside the access hole) which requires no resetting when adjusting the FOCUS or INTENSITY. The deflection plate terminals located on the periphery of the tube are connected through removable jumpers directly to the Main Vertical Amplifier.

### 3-3 SYNCHRONIZING CIRCUIT

The Synchronizing Circuit consists of an Input Amplifier-Phase Inverter (V8) and a Schmitt Trigger wave shaper (V9). V8 receives synchronizing signals either from the EXT. SYNC INPUT connector on the panel, the Main Vertical Amplifier, or from the line frequency, as selected by the SYNC selector

switch. All incoming sync signals are amplified and inverted in V8A, or are amplified without inversion in V8B. The desired polarity of sync signal that is to be used to start the sweep is then taken from the appropriate plate by the TRIGGER SLOPE control. A negative-going signal is required for the following Schmitt Trigger V9; consequently, positive input-sync signals are taken inverted from the plate of V8B while negative signals are taken uninverted from V8A.

The TRIGGER LEVEL control shifts all of V8's operating potentials in a positive or negative direction so an amplified input sync signal meets the trigger-voltage level of the following Schmitt Trigger with more or less sync voltage input.

Sync Schmitt Trigger V9 requires a negative-going input voltage to start the desired operation, and produces a reliable output pulse to start the Sweep Generator. Once triggered by the negative-going portion of the sync pulse, V9 must be reset by a positive-going voltage (which normally follows on a repetitive waveform) before it can again be triggered and start another sweep. If the input sync voltage moved only once in one direction it would produce a single sweep, but would not reset V9, and no more sweeps would be possible until V9 was returned to somewhat beyond its original state (see para. 3-6 for an explanation of the hysteresis in a Schmitt Trigger).

The negative output pulse from V9B is differentiated, producing a 5-volt negative spike which starts the sawtooth sweep.

Triggering Sensitivity Adjustment R66 varies the gain of V9A to vary the hysteresis of the trigger circuit, thus determining the input voltage level which will cause the trigger to switch state, (see para. 3-6). Triggering Symmetry Adjustment R72 varies the grid bias level on V9B to shift the hysteresis area of the trigger circuit in a positive or negative direction. This adjustment positions the hysteresis voltage limits equally above and below the 0-signal input voltage level. Since both controls affect the gain of the circuit, adjustment of either one affects the other; however, varying the plate load resistance of V9A varies the degree of hysteresis predominantly, while varying the grid bias on V9B varies the voltage position of the hysteresis area predominantly.

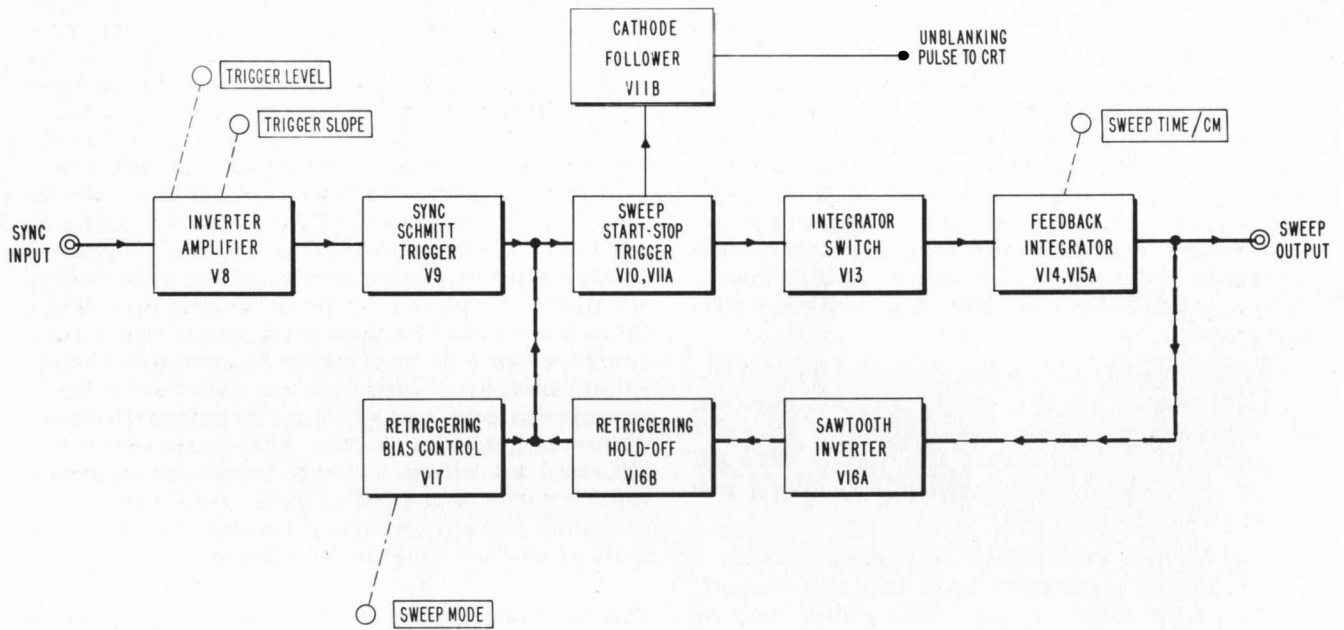

FIGURE 3-3



### 3-4 SWEEP GENERATOR

The Sweep Generator consists of tubes V10, V13, V14, V15 and V16, the sweep sawtooth slope being created by Feedback Integrator V14; the sawtooth slope being terminated by the feedback loop consisting of V16A, B and V17B. The sensitivity of the Sweep Generator to the trigger pulse from V9 is adjustable by the front panel SWEEP MODE control through V17A. The action of the circuit is as follows:

With no input sync pulse, Sweep Start-Stop Trigger V10 produces a low output-voltage which keeps Feedback Integrator V14 turned off. When V10A receives a negative sync pulse, it switches state and produces a high positive voltage which permits V14 to generate a linearly decreasing voltage. This decreasing voltage is inverted by V16A and fed back to the input of V10A through V16B and V17B. When the positive increasing voltage from V16A reaches a predetermined level (which is the upper hysteresis limit of V10), it triggers V10 back to its original state, shuts off the Feedback Integrator and terminates the decrease of voltage, thus creating a sawtooth. (See para. 3-6 for explanation of hysteresis in the Schmitt Trigger circuit.)

During the sawtooth, V10 cannot be re-triggered by subsequent negative sync pulses from V9 because V10A is in the cut-off condition.

To prevent subsequent negative sync pulses from retriggering V10 immediately after a sweep and to permit all circuits to recover, a hold-off bias is applied to the input grid of V10A. The hold-off bias maintains a sufficiently positive voltage on the grid of V10A so the negative-going sync pulses from V9 cannot drive the grid across the lower hysteresis limit and retrigger V10 until the hold-off voltage drops back to the normal grid-bias level. The hold-off bias voltage is obtained from a capacitor-discharge circuit, the discharge time being determined by the  $r$  and  $c$  values selected by the SWEEP TIME/CM selector.

The hold-off time is automatically adjusted to be from 3 times to  $1/20$  of the sweep time. During the sweep, V16B acts as a normal cathode follower, reproducing at its cathode the positive sloped sawtooth. During the retrace V16B is cut off. The cathode capacitor charged to the most positive voltage during the sweep, slowly discharges through the shunt resistors, providing a hold-off voltage for V10.

To vary the sensitivity of the sawtooth generator to the incoming negative sync pulses from V9, the negative grid-bias voltage applied to the grid of V10A is moved closer to or farther from the lower trigger level of V10. If the grid bias is adjusted with the SWEEP MODE control very close to the trigger point, V10 can be switched by very small negative voltages, if the bias voltage is reduced below the lower trigger point the sweep generator will free-run. If the grid-bias voltage is moved in a positive direction, away from the lower hysteresis limit, a larger negative pulse is required to trigger V10.

The negative sync pulses from V9 which trigger the sweep generator are 5 volts peak or greater for sync signals up to approximately one megacycle. Since the sweep generator is set to respond to input triggers of approximately 2 volts peak, when the SYNC control is set to PRESET, the sync pulses from V9 provide very reliable triggering for nearly all sync signals encountered. However, as the repetition rate of the incoming sync signal is increased above one megacycle, the spike from Schmitt Trigger V9 will decrease in size, and the sensitivity of the Sawtooth Generator must be increased by lowering the bias voltage to V10A with the SWEEP MODE control.

V17B serves to combine the variable bias with the sawtooth and hold-off voltages which are fed to the grid of Schmitt Trigger V10.

### 3-5 FEEDBACK INTEGRATOR AND DIODE SWITCH

The complete Feedback Integrator Circuit consists of Feedback Integrator V14 which creates the sawtooth slope, Diode Switch V13 which starts and stops the integrator action, and Cathode Follower V15A which provides d-c coupling from the Integrator plate to the grid. To direct-couple the Integrator plate to the Cathode Follower grid requires the three constant voltage lamps, I3, I4, and I5 in series to drop the d-c plate level to an appropriate value for the grid of V15A. Prior to the generation of a sawtooth, the plate-to-grid coupling is through the Diode Switch and the integrator-capacitor is shorted. During the generation of the sawtooth, plate-to-grid coupling is through the integrator capacitor. The operation of the circuit before and during a sweep is as follows:

Before a sync signal is received, Start-Stop Trigger V10 produces a relatively low, positive output-voltage level, which is fed through Cathode Follower V12A to the cathodes of the Diode Switch V13. The two diodes conduct, effectively shorting out the Integrator Capacitor (C55 through C63), and effectively connecting the plate of the Feedback Integrator to the grid through Cathode Follower V15A. This d-c degenerative feedback locks the circuit in a stable state holding the output voltage of the sweep generator stationary and the spot on the screen motionless. Thus the sweep starts from a fixed position regardless of sweep speed.

When a negative synchronizing pulse triggers Start-Stop Trigger V10, the Trigger produces a high, positive output-voltage which biases the Diode Switch V13 beyond cutoff, opens the Switch, and permits the Integrator grid voltage to rise and begin charging the feedback capacitor. While the grid side of the capacitor charges toward approx. +130 volts, the plate-side potential drops 80 volts for each volt of grid voltage rise.

The sawtooth slope is determined by the values of the grid-to-B+ resistor (R143 through R156) and the grid-to-plate capacitor (C55 through C63) as selected by the SWEEP TIME/CM selector switch.

To obtain the graduations in sweep time, beginning on the shortest sweep, the switch selects one capacity value and three different total resistance values (in the ratio of 1:2:5) for the first three ranges, and repeats this process using 10 x larger values of capacity; however, between the 5 and 10 microsecond ranges and between the .5 and 1 second ranges the capacity remains the same and the resistance value is increased by a factor of 10.

During the generation of the sawtooth, the grid-side of the capacitor has risen only 1/80 of the plate voltage swing, or approximately 1.4 volts. Since the first 1% portion of a capacitor charging curve is very linear, the resultant plate swing is also very linear. In addition, the degenerative plate-to-grid feedback through the integrator capacitor provides three important characteristics: it stabilizes the circuit so that normal changes in tube characteristics have little effect upon the slope and linearity of the sawtooth; it improves the linearity over that obtainable with a simple integrator followed by an amplifier; it increases the apparent value of the integrator capacitor by a factor equal to the gain of the integrator tube, as compared to the action of a simple integrator followed by an amplifier which multiplies the rate of rise of the capacitor charging curve by the gain of the amplifier. The apparent increase in value of the timing capacitor is due to the degenerative feedback inherent in the Feedback Integrator which reduces the tendency of the grid voltage to change by a factor equal to the gain of the amplifier.

A portion of the sawtooth voltage is coupled back to the Start-Stop Trigger to close the Diode Switch and to the sweep generator when its output has reached 110 volts. 110 volts is sufficient to cause a sweep 11 centimeters long. Closing the Diode Switch allows the timing capacitor to discharge and commences the retrace. During the sweep retrace, the integrator charging resistor is supplemented by R89 which is returned to -150 volts, thus giving a positive going voltage of constant slope at the output, in the same manner as described above.

For the various SWEEP TIME/CM ranges the ratio of retrace to sweep time varies from 1/3 to 1/1000 in accordance with the ratio of R89 to the particular charging resistance in use (R148 to R156).

### 3-6 SCHMITT TRIGGER CIRCUITS

A Schmitt Trigger consists of two amplifiers (twin triodes in the 150A) having d-c plate-to-grid coupling from A to B amplifier and d-c cathode-to-cathode coupling. The circuit has two stable states; A side conducting, B side cut off; B side conducting, A side cut off. The change-over from one state to the other is very rapid, producing fast rise and decay times from each side of the circuit, either of which can be used for triggering subsequent circuits.

The d-c voltage level applied to the A-side grid determines which state the circuit will be in. If the grid voltage is above a certain level, A side will conduct and B side will not; if below that same level, B side will conduct and A side will not. Each time the A-side grid voltage crosses this threshold, the circuit will change state. In practice, the threshold voltage is higher when moving the grid in a positive direction, and lower when moving the grid in a negative direction. The two different voltage levels are called the upper and lower hysteresis limits of the circuit.

To trigger the circuit, the A-side grid voltage must cross the particular hysteresis limit which will change the state of the circuit. If A side is already conducting, driving the grid voltage positive through its upper hysteresis limit will have no affect, but driving the grid voltage negative through its lower hysteresis limit will put A side out of conduction, and B side into conduction.

The initial A-side grid bias can be positioned anywhere inside or outside the hysteresis area, thus establishing the input voltage level required to change A's state. In the Sync Schmitt Trigger, the A-side grid bias is positioned midway between the upper and lower hysteresis limits, while in the Stop-Start Schmitt Trigger the grid bias is adjustable from below the lower hysteresis limit up to about midway between the hysteresis limits.

In the Sync Schmitt Trigger, A side is conducting and a negative sync signal is required to drive the grid voltage from the midway bias to below the lower negative hysteresis limit to switch the circuit. The input sync signal must then drive the grid beyond the upper positive hysteresis limit to reset the circuit for the next incoming sync pulse.

In the Start-Stop Trigger, A side is conducting, and the grid voltage can be set by the SWEEP MODE control to be below the lower hysteresis limit, in which case the trigger automatically switches state without an input trigger pulse and the sawtooth generator free runs. As the bias level is moved above the lower hysteresis limit, the circuit requires increasingly larger input trigger pulses to switch the trigger. The incoming sync signal is not large enough to pass the positive hysteresis limit, so cannot reset the trigger to its original state. The positive voltage which resets the trigger is obtained from the inverted sawtooth fed back to the A-side input.

### 3-7 HORIZONTAL AMPLIFIER

The complete Horizontal Amplifier consists of the Main Horizontal Amplifier which drives the deflection plates; and a preamplifier for signals applied to the EXT. HORIZ. INPUT permits vernier gain control and gives beam deflection to the right for negative input signals. The Main Amplifier is push-pull and the entire amplifier is direct-coupled. The Main Amplifier contains gain adjustments for the MAGNIFICATION ranges of the HORIZ. SENSITIVITY switch, frequency response, balance and centering adjustments. The preamplifier contains an input voltage divider, which in conjunction with the gain selector in the main amplifier, provides the EXT. INPUT VOLTS/CM ranges of the HORIZ. SENSITIVITY selector. The operation of the Horizontal Amplifier is as follows:

Horizontal deflection signals are selected either from the EXT. HORIZ. INPUT preamplifier or from the Sweep Generator by the HORIZ. SENSITIVITY selector and are then coupled to the grid of V20 through frequency-compensated voltage dividing networks. V20 and V21 are the two sides of a push-pull amplifier. The phase inverted signal for V21 is obtained through amplifier V19A and cathode Follower V19B. The inverted signal voltage is developed by bringing the two grid returns from V20 and V21 to a common point, and driving the phase inverter from this junction.

The maximum gain of the Main Horizontal Amplifier is set by adjusting R199 which varies the gain of Phase Inverter V19. Varying the gain of the Phase Inverter results in an unbalance in signal

levels to the grids of V20 and V21, but the balance is restored later in the amplifier by the common cathode resistors for V20, V21 and V23, V24.

The MAGNIFICATION and VOLTS/CM positions of the HORIZ. SENSITIVITY selector determine the horizontal deflection sensitivity by inserting input attenuators and adjusting the degeneration in the common cathode circuit of V20 and V21. In the X1 position, the cathode-to-cathode resistance is highest (gain minimum) and the sawtooth input to V20 is attenuated by a factor of approximately 10. In the X5 MAGNIFICATION position, the attenuation factor is reduced to approximately 2, increasing deflection sensitivity 5 times. In the X10, X50 and X100 MAGNIFICATION positions the cathode-to-cathode resistance of V20 and V21 is progressively decreased and the deflection sensitivity increased 2, 10 and 20 times over that present on the X5 position. The X100 Magnification Gain Adj. potentiometer, R213, provides minor adjustment in the cathode-to-cathode resistance to compensate for transconductance variations and is most effective in the X100 positions, when the cathode-circuit resistance is lowest.

Similar operations are performed in the EXT. INPUT positions. In the .2, .5, and 1 VOLT/CM positions of the HORIZ. SENSITIVITY selector, the gain ratios are set by cathode-to-cathode resistors as described above. Attenuation is inserted at the preamplifier input for the 2 and 5 VOLTS/CM positions.

There is an unlabeled switch position on the HORIZ. SENSITIVITY selector between the 5 VOLTS/CM and the X100 MAGNIFICATION positions. In this position, signals applied to the EXT. HORIZ. INPUT connector are fed directly to the Main Horizontal Amplifier without going through the Ext. Input Preamplifier. This position is useful during adjustment of the gain and frequency response of the Main Horizontal Amplifier. In this position the Main Horizontal Amplifier is connected exactly as in the X5 MAGNIFICATION position. Under these conditions the deflection sensitivity is 2 VOLTS/CM.

The push-pull signals from V20 and V21 are direct-coupled through Cathode Follower Drivers V22A and B to the Output Amplifiers V23 and V24. The signals

from the plates of the Output Amplifiers are returned through feedback networks to the input of the Drivers. The feedback networks contain adjustments of the transient response to assure linear amplification of the sawtooth voltage for all sweep times.

The signals from the Output Amplifiers are coupled through Output Cathode Followers V25A and B to the horizontal deflection plates. The Capacitance Drivers V26A and B improve the performance of the Output Cathode Followers during negative-going portions of the output waveform. Without a capacitance driver the output-tube impedance is increasing during a negative-going swing, and the increasing discharge time of the small circuit capacity prevents the cathode voltage from accurately following the grid voltage. This effect is prevented by increasing the current thru the Output Cathode Follower during periods when its output moves in a negative direction. The increase in cathode current is brought about by supplying the capacitance driver grid with a positive-going voltage through a differentiating network (C96, R239, and C95, R242) from the opposite side of the circuit. The Capacitance Driver for a particular side is ineffective during the positive-going portion of the output from that side.

Neon lamps are used in the grid circuits of V19B, V23, and V24 to provide direct coupling without loss of signal amplitude. The neon lamps are returned at -150 volts through a value of resistance that assures reliable lamp operation. A small bypass capacitor assures good coupling at high frequencies.

### 3-8 MAIN VERTICAL AMPLIFIER

The signal from the plug-in vertical amplifier is fed through the left-hand connector on the plug-in unit chassis to the Main Vertical Amplifier on the instrument chassis. The Main Vertical Amplifier consists of an input amplifier, delay line, buffers and output amplifiers, all push-pull and direct coupled. The entire circuit contains only two adjustments, a gain control to standardize the overall amplification and a frequency response control to compensate the high frequency end of the pass band.

Input amplifiers V1 and V2 provide a maximum gain of about 20 db. R5, the gain adjustment potentiometer, inserts degeneration in the cathode-to-cathode coupling between V1 and V2 to vary their gain over a 4 db range.

The signals from V1 and V2 are fed through two 0.25 microsecond delay lines (one in each side of the amplifier) to the final amplifier stages. Each delay line consists of a 25-inch length of RG-176/U coaxial cable. To provide satisfactory delay i.e., exactly equal phase shift in both sides of the amplifier at all frequencies, the physical lengths of the cables are cut to provide identical electrical lengths. Both ends of each cable are terminated with the resistance value which matches the characteristic impedance of the cable. These terminating resistors are R1, R12, R8 and R13.

At the various frequencies the operation of the circuit is as follows: Beginning at D-C and up to 25 cycles, the signal from V1 travels through R4 through the delay line, then R12 and a second resistor R10, thus giving a 50% signal loss at the grid of V3. At approximately 25 cycles, C1 and C5 become effective, shunt the two 330K resistors and produce a capacitive 2:1 division of the signal. At 3 KC the terminating resistors R4 and R12 are equal to the magnitude of the reactance of C1 and C5 and therefore at the high frequencies the line sees only R4 and R12 and is correctly terminated. V1 now sees its plate load R4 shunted by R12 at the other end of the line, thus cutting the plate load in half. The effect of the gradual transition from a 2:1 voltage divider to a 2:1 decrease in amplification provides flat amplification in conjunction with accurate matching over the band. To prevent capacitive mismatch of the delay lines at high frequencies the plate circuits of V1 and V2 are coupled to the delay lines through bridged-T networks. To reduce capacitive loading at the output end of the cables, double cathode followers are used as buffers ahead of the output amplifiers. The low-frequency gain of output amplifiers V6 and V7 is approximately 16 db. When replacing the delay lines, replace in pairs with specially prepared cables obtained from the Hewlett-Packard Company.

### **3-9 MODEL 152 DUAL TRACE AMPLIFIER PLUG-IN UNIT**

The Dual Trace (vertical) Amplifier contains two identical amplifiers, each with an input-sensitivity range switch, trace positioning circuit and about half of the total decibel gain

in the complete vertical deflection system. The output circuits of two amplifiers are joined and the resultant continuous signal is fed through push-pull cathode followers to the Main Vertical Amplifier on the instrument chassis. All circuits are direct-coupled; for a-c coupling, a blocking capacitor is switched between vertical input connector and the input attenuator.

At the input to each channel compensated voltage dividers provide attenuation of the input signal to control the vertical sensitivity of each channel in a 1, 2, 5, 10... sequence from 0.5 volts per centimeter (no attenuation of the input signal) by 20 volts per centimeter (attenuating the input signal by a factor of 400). Each step of attenuation is separate and independent of the others because there is no cascading of attenuator sections. Frequency response of each attenuator section is adjusted individually as explained in Section 4-18E.

The first stage of the Vertical Amplifier consists of push-pull cathode followers; one side receives the input signal, as determined by the input POLARITY switch; the input to the other side is grounded. The input signal is then fed to one side of the next stage the other side of which is effectively grounded. The two cathodes of the second stage are connected together thru the VERNIER and calibrate potentiometers. The potentiometers vary the cathode-to-cathode coupling and introduce cathode degeneration to vary the gain of the stage, and at the same time permit the stage to act as a phase inverter.

Holding the position of the trace stationary when the VERNIER gain control is varied, the plate currents of the two halves of the phase inverter do not change. This requires that the bias on the two tubes remains unchanged, which in turn requires that the VERNIER gain control be operated between points having zero potential difference. The BAL control adjusts the grid bias to one side of the phase inverter so that this condition is met.

The positioning of the spot is accomplished by equally and oppositely varying the d-c level at the two plates of the phase inverter. The d-c levels as well as the signals are then direct coupled to the following amplifiers. To prevent a change in current through the cathode resistors when the POSITION potentiometers are varied, a portion of the position-

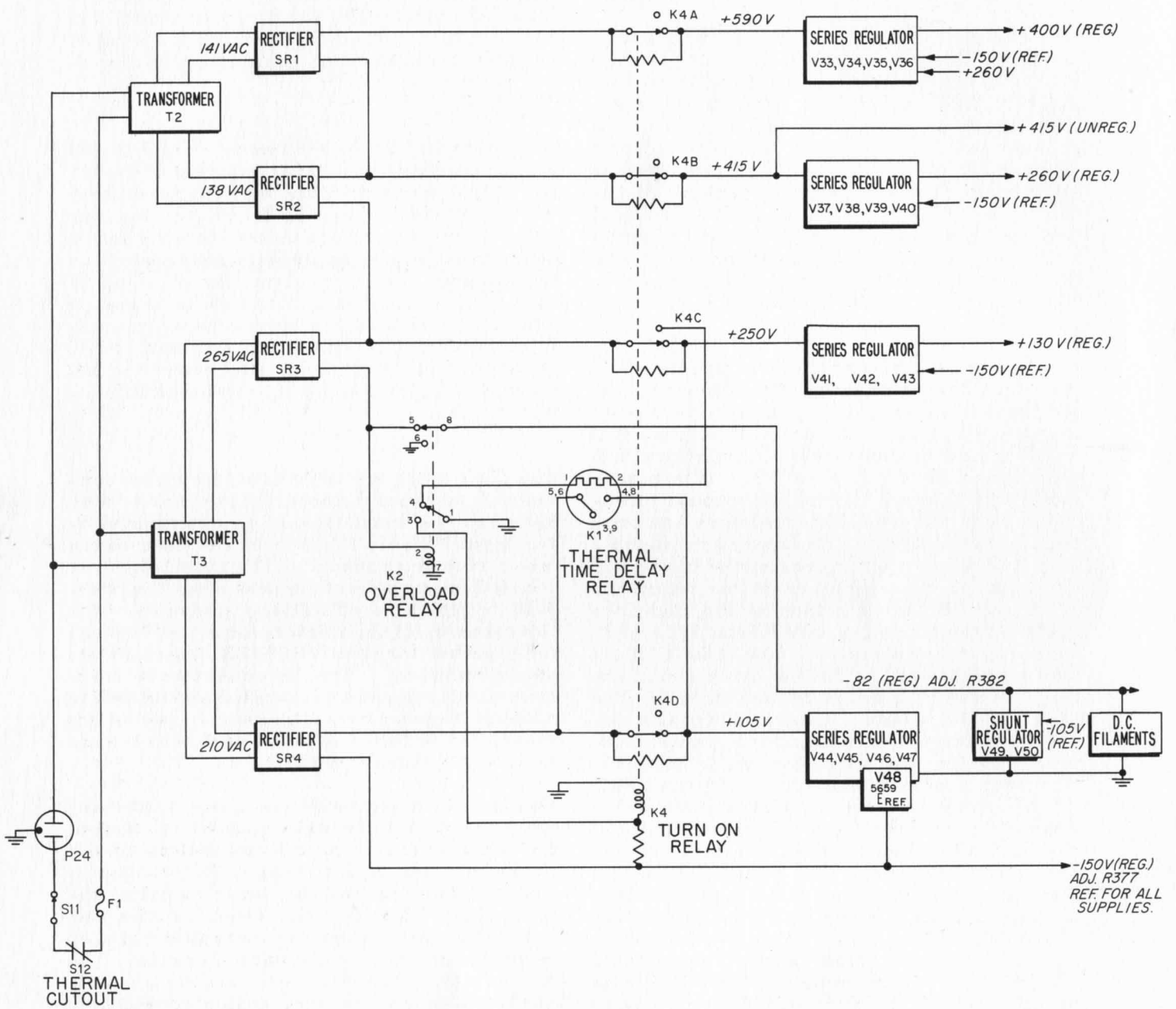

FIGURE 3-4

ing voltage is fed back to each cathode in such a manner that the currents remain unchanged.

The 3rd stage, Switched Amplifiers V503A and B, provides 15 db gain and also serves as a switch that can be turned off and on rapidly during ALTERNATE and CHOPPED operation. The plate circuits of the switched amplifiers are frequency compensated to extend the upper frequency limit to above 10 megacycles.

The plate circuits of the Switched Amplifiers in one channel are connected to the output of the other channel, without attenuation. No mixing of signals takes place since the amplifiers cannot be operated simultaneously; the "off" channel always appears as an open circuit to the "on" channel.

The Dual Channel Amplifier also contains circuits for switching the two channels off and on during CHOPPED and ALTERNATE operation.

For CHOPPED operation, the Switching Multivibrator free-runs at approximately 100 kilocycles, switching each of the channels off and on at this rate. During CHOPPED operation a fast negative pulse is taken from the Switching Multivibrator and applied through V504B to the CRT intensity grid so that the chopping lines between the two traces will be blanked out.

For ALTERNATE operation, a high negative bias converts the free-running multivibrator to a bistable flip-flop.

A signal obtained from the Sweep Generator at the end of each sweep switches the Multivibrator from one state to the other, thus alternately turning on one channel for one sweep, the other channel for the next.

### 3-10 CALIBRATOR

The calibrator circuit is a plate-coupled multivibrator which is made to free run at approximately 1000 cps, the rate being primarily determined by C116, R292 and C117, R285. The 100-volt square-wave output is positive-going with the base line clamped to ground by crystal diode CR2. The output voltage is selected from a voltage divider composed of R289, R290, R291 and the attenuator in the CALIBRATOR selector switch. The output half of the multivibrator tube, V32, is a pentode whose screen serves as the plate for the

multivibrator, while the pentode plate serves to electron-couple the multivibrator to the output circuit. During the negative-going portion of the output waveform, tube conduction discharges stray capacities rapidly and affords a comparatively fast decay time. To improve waveform rise-time when the tube goes out of conduction, CR1 clamps a portion of the plate load to the +130-volt buss during the positive-going half of the wave. This effectively reduces the resistance through which stray capacities must charge, thus reducing rise time, while retaining a high plate-load resistance to limit tube conduction during the negative-going half of the waveform.

### 3-11 REGULATED LOW-VOLTAGE POWER SUPPLY

The complete low-voltage power supply shown in figure 3-4 provides five regulated and one unregulated voltages as follows: regulated, -150 volts, -82 volts, +130 volts, +260 volts and +400 volts; unregulated, +415 volts.

Each regulated voltage supply except the -82 volt has its own transformer winding and rectifier. The -150-volt supply contains the reference voltage for all other regulated supplies and is thus the only independent one. The unregulated outputs from the rectifiers which supply the three positive-voltage supplies are stacked in series. The higher-voltage regulated supplies tap in at higher voltages on this stack. The total current requirement of the three positive-voltage regulated supplies must flow through the lowest rectifier in the stack, which is sufficient for d-c heater current to a series string of electron-tubes. Thus the negative return of the lowest stacked supply is returned to ground through the tube heaters as a load with the total heater voltage held constant by a shunt voltage regulator. The shunt regulator, V49 and V50, absorbs slight differences in the 150A's instantaneous current requirements and input variations such that the voltage applied to the d-c heater string is constant.

The operation of the four regulated-voltage supplies is identical so only the -150v supply is described. V44, V45 and V46 are the regulator tubes which act as variable resistors controlled by the voltages at the control and screen grids of Control Tube V47. If the regulated output voltage from the cathode of the Series Regulators tends to increase, the voltage at the grid of V47 tends to increase, causing V47 to draw more current. This lowers the plate voltage of V47 and con-

sequently the grid voltage on the series regulators, resulting in greater plate resistance in the series regulators. The greater plate resistance causes a larger voltage drop across the tubes, instantaneously compensating for the increased voltage output, and results in substantially constant voltage output. If the regulated output tends to decrease, the reverse of the above action occurs. The screen of V47 is used as a control grid for connecting variations and ripple in the unregulated input voltage in exactly the same manner. The three screen resistors are chosen so that input voltage changes of  $\pm 10\%$ , as caused by line voltage variations are almost wholly screen-compensated. Ripple at the input to the regulator is thus substantially reduced below the level possible by control-grid compensation. Ripple in the output voltage is coupled to the grid V47 by capacitor C143, while slow variations in the d-c level are fed to the grid of V47 through voltage divider R378, R379 and R380. The normal bias for V47 and the resultant output voltage from the regulators, is determined by the setting of potentiometer R379. The heater voltage for Control Tubes V40, V43 and V47 (controlling -150v, +130v and +260v outputs) are d-c regulated to eliminate tube contact-potential changes occurring with line-voltage variation, thus permitting extremely constant output voltages. This extremely close regulation provides the high d-c amplifier stability necessary for very low trace drift.

In the complete Low Voltage Power Supply there are four protective switches of which three are dc relays and one is a temperature actuated switch. Dc relays K1 (Thermal Time Delay Relay), K4 (Turn on Relay), and K2 (Overload Relay) protect the components of the oscilloscope from damage due to excessive voltages during the turn on period when current drain is low and output voltages tend to be high and from damage due to excessive current because of an overload or a short circuit. S12 Thermal Cutout, a temperature actuated switch, protects the oscilloscope from damage caused by excessive operating temperatures. Should the fan fail, the filter become clogged, or ambient temperature rise, S12 will shut off the instrument when the operating temperature at S12 reaches approximately 150°F.

During the time that the 150A is warming up there is almost no load on the power supplies and consequently their output voltages would rise excessively if no steps were taken to prevent such a rise. Thermal Time Delay K1 and Turn On Relay K4 prevent this rise of

voltage during the turn on period. Figure 3-4 is a block diagram of the Low Voltage Power Supply showing these relays and Overload relay K2 in the normal operating position. When power is first applied to the instrument K4 is not energized and its contacts are in the upper position. Input voltage into the series regulators is effectively reduced nearly to chassis level by the series resistors and K1 receives heater voltage from SR3. In addition to operating K1, SR3 furnishes heater current to the tubes in the dc heater string so that these tubes will be ready to operate by the time relay K1 closes. When relay K1 closes and allows the -150 volt supply to come up to full output, relay K4 is energized. Energizing K4 shorts out the series resistors in the other supplies and permits their outputs to rise to their operating values. Contacts K4C remove the heater voltage from Thermal Time Delay Relay K1 permitting it to cool and its contacts to open. Since K4 also has contacts which short the series resistor in the -150 volt supply, the cooling of K1 has no effect. However, once K1 has cooled, any interruption of ac power or of energizing voltage for K4 de-energizes K4 and thus lowers all regulated output voltages until the time delay cycle is completed.

Overload Relay K2 is energized whenever the dc heater voltage (-82 vdc) exceeds -110 volts. Since this voltage is dependent upon the current from the three positive voltage rectifiers (after the range of the shunt regulator has been exceeded) an excessive increase of current from any positive supply will trip Overload relay K2. K2 operates by de-energizing K4 to lower the voltage outputs of the series regulator as previously explained; by removing excitation voltage to the heater of K1; and by disconnecting the Shunt Regulator and the dc heater string from the -82 volt buss. If K2 did not remove the excitation voltage from K1's heater, K1 would go through its cycle of operation and connect the -150 volt supply for full output. Disconnecting all loads except the overload relay from the -82 volt buss causes all current from the positive supplies to flow through K2 thus keeping K2 energized until ac power to the instrument is interrupted. In fact, a filter capacitor in the power supply keeps K2 energized for several seconds after ac power has been removed from the instrument.

Keeping the output voltages of the Low Voltage Power Supply depressed during turn on also keeps the outputs of the High Voltage Power Supply within bounds since its output voltages are dependent upon the plate and screen voltages of the rf oscillator, V27.



### 3-12 REGULATED HIGH-VOLTAGE POWER SUPPLY

The cathode of the CRT in the 150A is operated at -4800 volts, the intensity grid at approximately -5000 volts each obtained from a supply which has an independent transformer seconding winding and rectifier, but driven by a single 60-kc high voltage oscillator.

A feedback-control amplifier V28, regulates the CRT cathode supply by determining the 60-kc oscillator's screen voltage and hence its power output. Any tendency for the output voltage of the Cathode Supply to shift is approximately cancelled by increasing or decreasing the amplitude of oscillation as required to compensate for that shift. The CRT grid-supply voltage being unregulated, varies slightly as CRT beam current is varied. This variation, however, occurs only when the beam intensity and hence oscillator excitation are varied, and is proper.

The Intensity Grid Supply is separate in order to couple CRT unblanking pulses, which vary in rate from almost d-c to radio frequency, to the Intensity Grid. To accomplish this, the supply is floating; the low-voltage end of the supply is connected to Unblanking Cathode Follower V11B in the Sweep Generator, the high-voltage end to the intensity grid through the INTENSITY control. The entire intensity-grid supply rises and falls with the unblanking pulse from V11B and the pulse is transmitted directly to the intensity grid.

The winding and stray capacities in the secondary of this supply are such that the electrical ground of the winding, with regard to the oscillator driving voltage, is shifted from the low-voltage side of the winding toward the high-voltage side. This introduces a considerable 60-kc signal voltage into the low-voltage lead, which if not suppressed, would create objectionable intensity and sweep modulation on the scope trace at the high-voltage, 60-kc oscillator frequency. This undesired 60-kc voltage is balanced out by the introduction of an out-of-phase charging current which is supplied through C107 and C108. C108 is adjusted for minimum trace distortion under the following most adverse conditions:

Mag: X100  
Sweep: 10, 20, and 50 ms/cm  
Input: 1-kc sinewave, 6-cm deflection  
Intensity: dim  
Focus and Astigmatism: optimum

Any residual distortion should be almost all 6th harmonic of the oscillator fundamental which is unavoidable.

### 3-13 SINGLE SWEEP AND DELAYED SWEEP OPERATION

Other descriptions of the operation of the 150A Sweep Generator apply principally to normal sweep operation, i. e., with S4 (inside the top access door) in the NORMAL position. Several useful modes of operation are possible with S4 in the SINGLE SWEEP position. In SINGLE SWEEP operation, starting from the already reset condition, a single sweep can be started through any of the usual channels, and the sweep terminates in the usual fashion. Before another sweep can be initiated, no matter how many triggers arrive meanwhile, a specific resetting action is necessary; the resetting action can be done either manually by use of the SWEEP MODE control or electronically by application of an appropriate pulse to the RESET connector inside the access door.

For SINGLE SWEEP operation, S4 converts V17 to a Schmitt Trigger circuit, and ties the cathodes of V17A, V17B, and V16B together. In this explanation it will be assumed that the sweep generator is in the armed condition; the SWEEP MODE control is in the PRESET position; V17A is conducting, V17B cutoff; indicator lamp I6 is lit, indicating the armed condition; with these conditions the next negative sync pulse from Schmitt Trigger V9 will start a sweep. Refer to Figure 3-5; the armed level at the common cathodes is  $E_1$ , and the trigger occurs at  $t_1$ . At time  $t_2$ , shortly after the sweep has been triggered, the positive-slope sawtooth at the grid of V16B causes its cathode to take control of the common cathode circuit and to raise that voltage until the lower hysteresis limit of Schmitt Trigger V17 is reached. When this happens, at time  $t_3$ , conduction switches from V17A to V17B (indicator lamp I6 goes out) and the cathode

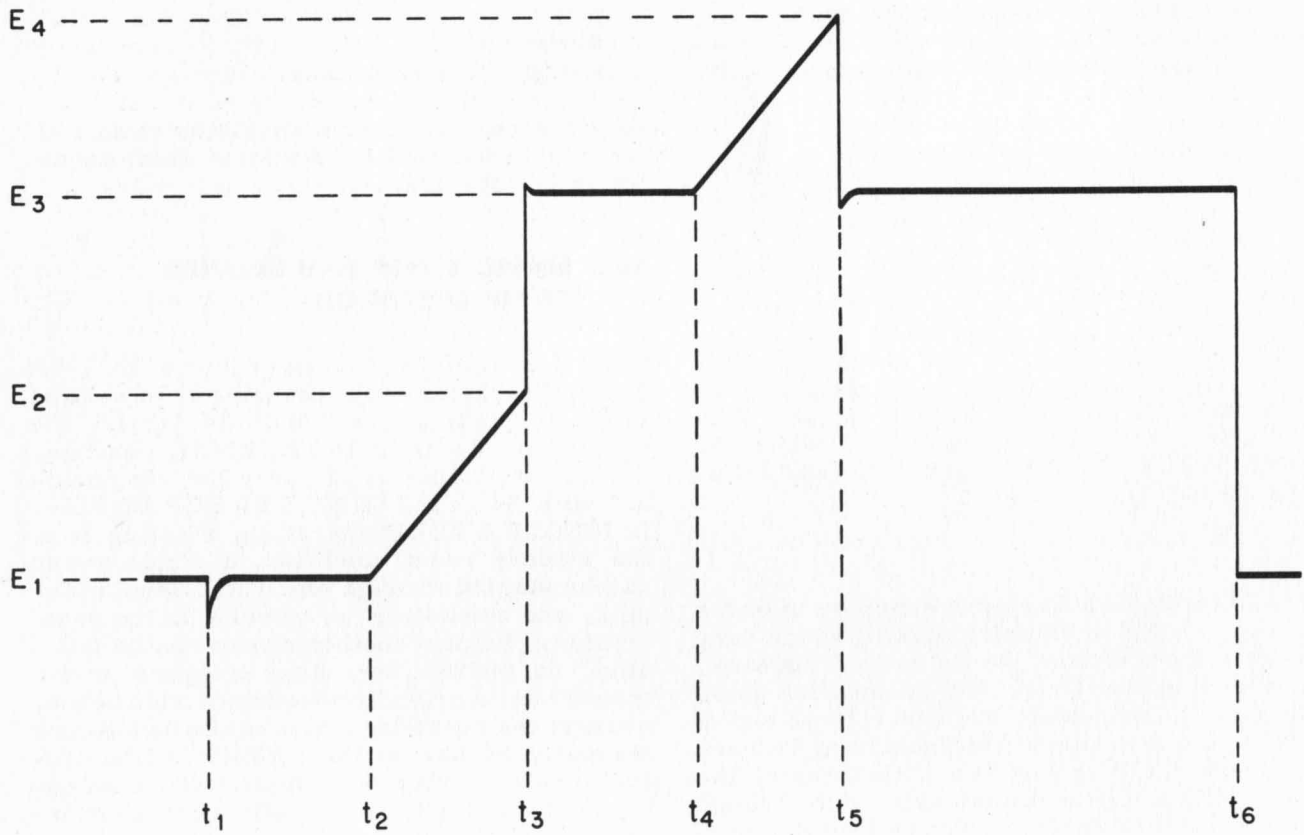

FIGURE 3-5

potential jumps to E<sub>3</sub>; from time t<sub>3</sub> to time t<sub>4</sub> V17B controls the common cathode voltage. Eventually, the inverted sawtooth at the grid of V16B rises to such a value that V16B regains control of the common cathode circuit, and when E<sub>4</sub>, the upper hysteresis limit of V10, is reached, the sweep is terminated, at time t<sub>5</sub>. At the termination of the sweep, the voltage at the grid of V16B drops back to E<sub>3</sub>, at which time V17B regains control and establishes the lock-out bias applied to the grid of V10A. This lock-out bias level E<sub>3</sub> is thus the same as the level established at t<sub>3</sub> when conduction was switched from V17A to V17B. As long as this condition remains the sweep cannot be retriggered, since the output of Sync Schmitt Trigger V9 is insufficient to overcome the lock-out bias. To reset the sweep circuit so that it can again be triggered by V9, it is necessary to switch conduction from V17B back to V17A (at which time indicator lamp I6 will re-light). This can be done manually by rotating the SWEEP MODE control away from PRE-SET and back again, or it can be done electronically by applying a resetting pulse to the RESET connector inside the top access door (the pulse must be from one to four microseconds wide and from +15

to +25 volts high). In Figure 3-5 reset is shown at time t<sub>6</sub>, when the common cathode voltage drops from E<sub>3</sub> back to E<sub>1</sub>.

Manual single-sweep operation is convenient for viewing or photographing a single non-recurrent phenomenon; electronic-reset operation in conjunction with an external delay generator as the source of the resetting pulse will normally be used in viewing repetitive waveforms. Two modes of electronic-reset operation are available. One mode, obtained with the SWEEP MODE control set to PRE-SET, provides a sweep triggered by the first vertical signal after the reset pulse; thus the display is not affected by jitter between the delay trigger and the signal under observation. The other mode, obtained with the SWEEP MODE control in FREE-RUN, starts a sweep instantaneously after the reset pulse, regardless of the presence or absence of vertical signals, usually the same results can be obtained without an external delay generator through NORMAL operation of the sweep generator in conjunction with the INT. SWEEP MAGNIFICATION positions of the HORIZ. SENSITIVITY selector.

## SERVICING ETCHED CIRCUITS

- ① APPLY HEAT SPARINGLY TO LEAD OF PART TO BE REPLACED. REMOVE PART FROM BOARD AS IRON MELTS THE SOLDER.

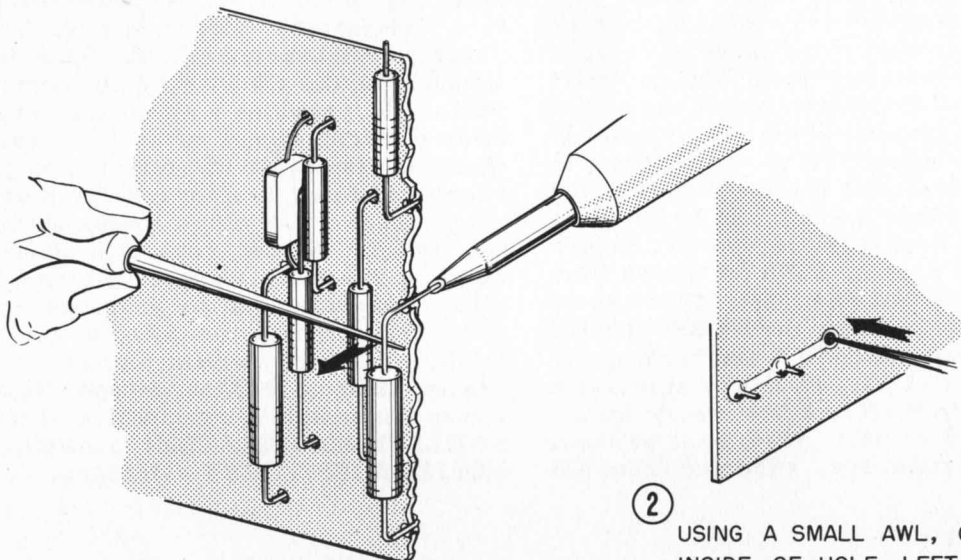

- ② USING A SMALL AWL, CAREFULLY CLEAN INSIDE OF HOLE LEFT BY OLD PART.

- ③ BEND CLEAN LEADS ON NEW PART AND CAREFULLY INSERT THROUGH HOLES ON BOARD.

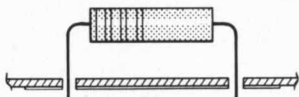

- ④ HOLD PART AGAINST BOARD AND SOLDER LEADS.

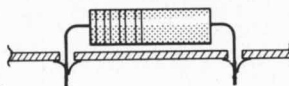



FIGURE 4-1

## SECTION IV

### MAINTENANCE

#### 4-1 INTRODUCTORY

This section contains instructions for adjusting and servicing the 150A Oscilloscope. The 150A is constructed so that each of the major circuit sections is physically located on a single etched circuit board, except for the Main Vertical Amplifier which utilizes two separate chassis. The material in this section is divided as the circuit sections, each section having a complete set of adjustment instructions, and at the rear of the manual, a schematic and a voltage-resistance diagram. The material in this section is as follows:

- 4-2 Replacing the Air Filter
- 4-3 Removing the Cabinet
- 4-4 Connecting for 230 - Volt Power Lines
- 4-5 Servicing Etched Circuits
- 4-6 Tube Replacement Chart
- 4-7 Isolating Troubles to Major Sections
- 4-8 Adjusting the Low-Voltage Supplies
- 4-9 Adjusting the RF High - Voltage Supply
- 4-10 Replacing and Adjusting the CRT
- 4-11 Adjusting the Calibrator
- 4-12 Adjusting the Main Horizontal Amplifier
- 4-13 Adjusting the Ext. Horiz. Input Preamplifier
- 4-14 Adjusting the Sync Circuit
- 4-15 Adjusting the Preset Sensitivity of the Sweep Generator
- 4-16 Calibrating the Sweep Generator
- 4-17 Adjusting the Gain and Frequency Response of the Main Vertical Amplifier
- 4-18 Adjusting the  152A Dual Trace Amplifier

#### 4-2 REPLACING THE AIR FILTER

The air-filter element in the 150A is a renewable type. It is retained in the bottom of the instrument cabinet by two bullet catches, and is removed by pulling straight down. To renew the filter element, wash in warm water

and detergent, then recoat with the special oil, Filter Coat No. 3, made by Research Products Corp., Madison 10, Wisconsin. Inspect the air filter often when the 150A is in constant use.

#### 4-3 REMOVING THE CABINET

The 150A chassis and panel are removed from the cabinet by removing the four retainer screws on the rear of the cabinet and sliding the chassis forward out of the cabinet.

#### 4-4 CONNECTING FOR 230-VOLT POWER LINES

The 150A is normally shipped from the factory with the dual primary windings of the two power transformers connected in parallel for use on 115-volt a-c lines. The windings can easily be reconnected in series for use on 230-volt power if desired. The primary connections to both power transformers are identical, and each requires the same change in connections. To reconnect the primary windings of T2 and T3 for use on 230 volts, on each transformer disconnect the jumpers which join terminals 1 to 4 and 2 to 5. Connect 10-ohm disk thermistors RT301 to T2 and RT302 to T3 between terminals 4 and 5. Replace the 6-amp fuse with a 3-amp fuse and the 150A can now be operated from 230 volt lines with no change in operation.

#### 4-5 SERVICING ETCHED CIRCUITS

Figure 4-1 illustrates how to replace electrical parts on etched circuits.

When servicing etched circuits, DO NOT push or pull wires in such a way as to raise the wiring from the board.

When soldering leads on the etched board, use a 50 watt iron or smaller. Apply heat sparingly to the leads on the part to be replaced, not to the wiring on the board.

Before installing new parts, clean holes to receive new part without forcing. Have new

# MAJOR SECTIONS

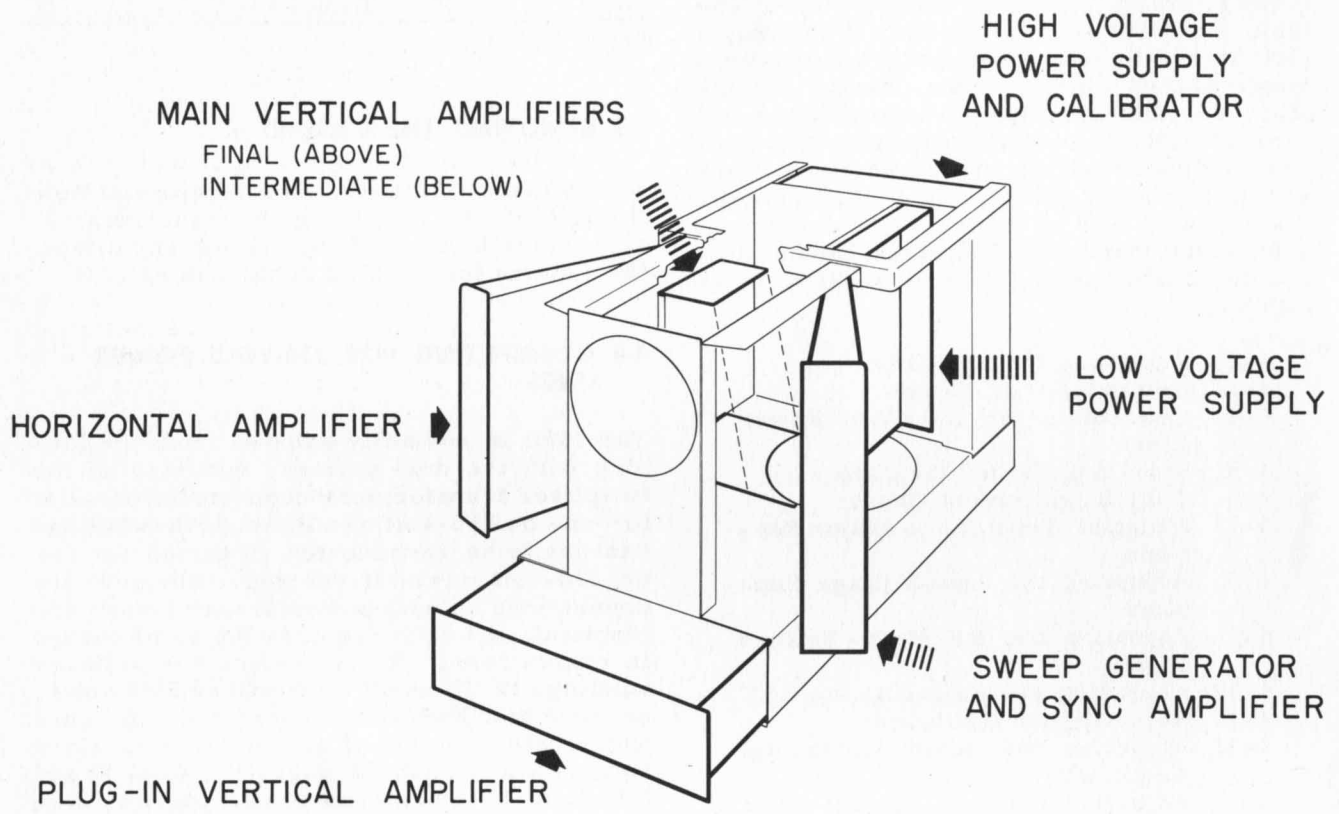

FIGURE 4-2

leads tinned and if necessary fluxed to receive solder quickly with a minimum of heat and without residue.

#### 4-6 TUBE REPLACEMENT CHART

The heaters of some of the tubes in the 150A Oscilloscope are operated in series from a regulated d-c voltage obtained from the Low-Voltage Power Supply. This series heater string is shown in one piece on the Low-Voltage Power Supply schematic diagram; the actual connection through each circuit is shown individually on the schematic of the circuit. When replacing tubes during trouble shooting, if one of the series tubes is pulled, it will turn off all the other tubes in the string.

#### 4-7 ISOLATING TROUBLES TO MAJOR SECTIONS

In any case of trouble shooting, attempt operation of the various sections of the oscilloscope and determine which major section contains the circuit failure. When this is determined, refer to the Location Diagram, the Voltage-Resistance Diagrams and the Tube Replacement Chart for assistance with changing tubes and measuring voltages and resistances in each circuit. See that all the tubes are lighted; check by replacement or with a tube checker; then measure voltages. Start by measuring the voltages of the main power leads from the power supply, then measure voltages at the sockets of tubes in the circuits which are suspected. When trouble shooting direct-coupled, push-pull circuits, the two sides of the circuit are normally balanced and cause the spot to be stationary in the center of the scope screen. A fault in either side will usually unbalance the circuit and cause the spot to move off the screen. To bring the spot back, short together the control grids (or the plates) of the two sides of one stage. This eliminates signals of all types, d-c unbalance, jitter, etc. which originate prior to the shorted points. If shorting the two halves of a stage together does not bring the spot on the screen and hold it motionless, a subsequent circuit is faulty. By continuing this process through the amplifier the trouble can be isolated to a small circuit area. If shorting the plates together returns the spot, the trouble can be in the plate-load resistors or in the grid or cathode circuits of the following stage.

a. Check the Low-Voltage Power Supply voltages as described in paragraph 4-8.

b. Check the High-Voltage Power Supply voltages as described in paragraph 4-9.

c. Check the Calibrator as described in paragraph 4-11. The Calibrator can then be used to quick-check the horizontal and vertical amplifiers and the sync circuits.

d. Check the Sweep Generator. With the SWEEP MODE control, attempt free-running; then, stop the free-running. Connect the CALIBRATOR output to the SYNC input and attempt synchronization with various CALIBRATOR output levels at various settings of the SWEEP MODE control. With instrument out of cabinet, note condition of the "SWEEP ON" neon indicator lamp. If the lamp is not lighted no sweep is in process, since the lamp is operated by the sweep "turn-on" voltage.

e. Check the Vertical Amplifier by connecting the CALIBRATOR output to the vertical inputs. Note the resultant deflection and wave shape. If one channel of the plug-in does not operate, trouble shoot that channel; if neither one operates properly, trouble shoot the Main Vertical Amplifier.

f. Check the Horizontal Amplifier in the same manner as the Vertical Amplifier.

#### 4-8 ADJUSTING THE LOW-VOLTAGE POWER SUPPLIES

The complete, low-voltage power supply provides five, separately-regulated output voltages: -150 vdc, -82 vdc, +130 vdc, +260 vdc and +400 vdc. All are located on the one etched circuit shown in Figure 4-3. The low voltage supply has two interdependent adjustments which set the -82-volt filament supply and the -150-volt output. There are no separate adjustments for the +130-volt, +260-volt and +400-volt regulated supplies. All the positive voltages depend upon correct adjustment of the -150-volt supply; the +400 vdc supply depends also upon having the correct output voltage from the +260-volt supply.

All regulated voltages can be conveniently measured through the access hole over the High-Voltage Power Supply etched-circuit board at the top-rear of the instrument chassis. To adjust the -82-volt and the -150-volt supplies refer to Figure 4-3 and proceed as follows:

TUBE REPLACEMENT CHART

MAIN VERTICAL AMPLIFIER			
Tube Designation	Tube Type	Tube Function	Adjustment Required
V1, V2	6197 or 6CL6	Input Amplifier	Adjust the Main Vert. Ampl. Gain, R5 (see para. 4-17)
V3 AB V4 AB	6BQ7A	Double Cathode Followers	No adjustment required.
V5, V6	6197 or 6CL6	Output Amplifiers	Adjust the Main Vert. Ampl. Gain, R5 Adjust High Frequency Response, C8 (see para. 4-17)
V7 AB	6AU8	Internal-Sync Preamplifier	No adjustment required.
SWEEP GENERATOR			
V8	6BQ7A	Sync Amplifier-Inverter	No adjustment required.
V9	6BQ7A	Sync Schmitt Trigger	Adjust Trigger Sensitivity, R66 (see para. 4-14) Adjust Trigger Symmetry, R72 (see para. 4-14)
V10 AB	6BQ7A	Sawtooth Start-Stop Trigger	Adjust Preset Adj., R103 (see para. 4-15)
V11 AB	1/26BQ7A	Cathode Followers	No adjustment required.
V12 AB	1/26BQ7A	Cathode Followers	No adjustment required.
V13	6AL5	Integrator Switch	No adjustment required.
V14	6AH6	Feedback Integrator	Adjust Sweep Amplitude, R122 Calibrate Sweep Speeds, R143, R144, R145, R157, C59, C61, C41, C78 (see para. 4-16)
V15 AB	6BK7A	Cathode Followers	No adjustment required.
V16 AB	6BQ7A	Sawtooth Inverter and Re-triggering Holdoff Cathode Follower	Adjust Preset Adj., R103 (see para. 4-15) and Adjust Sweep Amplitude R122 (see para. 4-16a)



TUBE REPLACEMENT CHART

SWEEP GENERATOR (Cont'd.)			
Tube Designation	Tube Type	Tube Function	Adjustment Required
V 17 AB	6BQ7A	Retriggering Bias Control Tube	Adjust Preset Adj., R 103 (see para. 4-15)
HORIZONTAL AMPLIFIER			
V 18	6BQ7A	Ext. Horiz. Input Pre-Amplifier	Adjust Input Capacity Adj., C74 and Frequency Response Adj., C75. Adjust Ext. Gain, R178 Adjust Ext. Bal., R185 (see para. 4-13)
V 19 AB	6BQ7A	Amplifier-Phase Inverter	No adjustment required.
V20, V21	6AH6 or 6845	Push-Pull Amplifiers	Adjust Main Horiz. Gain (see para. 4-12a) Adjust X100 Magnification Cal. (see para. 4-12b) Adjust X5 to X100 Magnification Centering and X1 Centering (see para. 4-12c) Adjust Frequency Response (see para. 4-12d)
V22 AB	6BQ7A	Push-Pull Cathode Followers	No adjustment required.
V23, V24	6197 or 6CL6	Push-Pull Output Amplifiers	Adjust Main Horiz. Gain (see para. 4-12a) Adjust Frequency Response (see para. 4-12d)
V25 AB	6BQ7A	Push-Pull Output Cathode Followers	No adjustment required.
V26 AB	6BQ7A	Push-Pull Capacitance Drivers.	No adjustment required.
HIGH VOLTAGE SUPPLY AND CRT CIRCUIT			
V27	6AU5GT	HIGH VOLTAGE POWER SUPPLY 60-KC, Hi-Voltage Oscillator	Check both high-voltage outputs. (see para. 4-9)
V28 AB	12AU7	Voltage Control Tube	Check both high-voltage outputs. (see para. 4-9)

TUBE REPLACEMENT CHART

HIGH VOLTAGE SUPPLY AND CRT CIRCUIT (Cont'd.)			
Tube Designation	Tube Type	Tube Function	Adjustment Required
HIGH VOLTAGE POWERSUPPLY			
V29	3A2	Beam Hi-Voltage Rectifier	Check both high-voltage outputs. (see para. 4-9)
V30	3A2	Intensity Hi-Voltage Rectifier	Check both high-voltage outputs. (see para. 4-9)
V31	5AMP	Cathode Ray Tube	Adjust Astigmatism, (R2, R3) Main Vert. Gain Adj., R5 Main Horiz. Gain Adj., R199 (see para. 4-10, 4-17, and 4-12a)
CALIBRATOR			
V32	6U8	1-KC Multivibrator	No adjustment required. Visually inspect waveform.
LOW VOLTAGE POWERSUPPLY			
V33, V34, V35	12B4A	+400-Volt Series Regulators	No adjustment required.
V36	6BH6	+400-Volt Control Tube	No adjustment required.
V37, V38, V39	12B4A	+260-Volt Series Regulators	No adjustment required.
V40	6BH6	+260-Volt Control Tube	No adjustment required.
V41, V42	12B4A	+130-Volt Series Regulators	No adjustment required.
V43	6BH6	+130-Volt Control Tube	No adjustment required.
V44, V45, V46	12B4A	-150-Volt Series Regulators	Check -150V Adjust. (see para. 4-8)
V47	6BH6	-150-Volt Control Tube	Check -150-Volt output (see para. 4-8)
V48	5651	Power Supply Reference Tube	Check -150-Volt output (see para. 4-8)
V49 AB	12AX7	-82-Volt Control Tube	Check -82-Volt output (see para. 4-8)
V50	12B4A	-82-Volt Shunt Regulator	No adjustment required.

TUBE REPLACEMENT CHART

hp MODEL 152A DUAL TRACE AMPLIFIER			
Tube Designation	Tube Type	Tube Function	Adjustment Required
V501 in A V507 in B	6BQ7A	Input Cathode Followers	Adjust Input Capacitors, C517 and C518 for INPUT A, C548 and C549 for INPUT B. (see para. 4-18d) Adjust Balance, R519 for INPUT A, R586 for INPUT B. (see figure 2-11)
V502 in A V508 in B	6BQ7A	Phase Inverter	Adjust Vert. Gain Cal. R524 for INPUT A R589 for INPUT B (see figure 2-14) Adjust Vertical Centering R561 (see para. 4-18a) Adjust Balance, R519 for INPUT A R582 for INPUT B (see figure 2-11)
V503 in A V509 in B	6BQ7A	Switched Amplifiers	Adjust Neut. Capacitor, C519 Adjust Neut. Capacitor, C520 (see para. 4-18b)
V504 AB	6AN8	Alt. Sweep Trigger Amp. and Cathode Follower	No adjustment required. Check triggering at highest sweep rates.
V505	12AU7A	Switching Multivibrator	Select tube for best symmetry during chopped operation.
V506 AB	6BK7A	Amplifier	Make certain that the trace does not switch channels before the end of a sweep on ALTERNATE operation. Check on slowest sweep speed.
V510	6BQ7A	Output Cathode Follower	Adjust Vertical Centering, R561 (see para. 4-18a)

# LOW VOLTAGE POWER SUPPLY REGULATOR

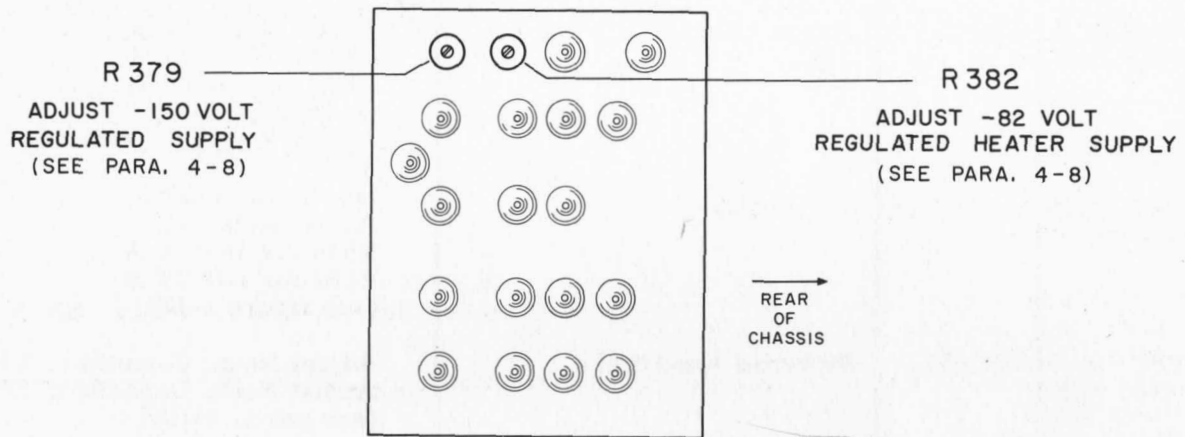

FIGURE 4-3

- a. Remove the 150A from the cabinet; turn on and allow to warm up for 5 minutes.
- b. With an accurate d-c voltmeter, measure the d-c voltage between the -150-volt measuring point and chassis.
- c. If necessary, adjust R379 to obtain -150 volts.
- d. Measure the d-c voltage between the -82-volt measuring point and chassis.
- e. If necessary, adjust R382 to obtain -82 volts.
- f. Recheck the -150-volt supply. Measure the +130, +260 and +400 volt outputs. The voltages of these supplies are fixed by 1% resistors and should be within 2% of their specified voltages.
- c. Connect a d-c voltmeter having an input impedance of 1000 megohms between ground and the -4800-volt measurement point.
- d. If necessary, adjust R275 to obtain -4800 volts.
- e. Measure the d-c voltage at the grid of the CRT when the intensity is turned to minimum.
- f. To minimize the ripple on the -5000-volt output set the SWEEP TIME/CM selector to the 20 MILLISEC/CM and the HORIZ. SENSITIVITY selector to the X100 position.
- g. Apply a 500 cps sine wave to the vertical INPUT A to obtain a sine presentation on the 150A showing one cycle of sine wave.
- h. Using an insulated screwdriver, adjust C 108A to obtain minimum residual ripple modulation on the sine wave trace.

#### 4-9 ADJUSTING THE RF HIGH-VOLTAGE POWER SUPPLY

Be careful when adjusting the high-voltage CRT beam and intensity supplies; the voltages for the CRT cathode and intensity control grid are -4800 and -5050 volts to chassis, respectively. Use a high-voltage, high impedance probe such as Model 459A DC Resistive Voltage Multiplier with the 410B Voltmeter.

The r-f high-voltage supply provides two separately rectified dc output voltages from a single 60 kc oscillator; -4800 vdc regulated for the cathode of the CRT and -5000 vdc unregulated for the grid. R275 (see Figures 4-4 and 4-13) sets the -4800 vdc cathode voltage by controlling the amplitude of oscillation of the oscillator and thus varies the grid supply voltage at the same time. However, the grid voltage should remain between -4950 vdc and -5050 vdc when the INTENSITY control is turned to minimum and no sweep is occurring.

To adjust the high voltage supply refer to Figure 4-4 and proceed as follows:

- a. Remove the instrument from the cabinet. Turn the instrument on and allow to warm up for 5 minutes.
- b. Check the output of the low-voltage power supply (see paragraph 4-8).

#### 4-10 REPLACING AND ADJUSTING THE CRT

##### WARNING

HANDLE THE CATHODE RAY TUBE CAREFULLY. Impulsion causes broken pieces to travel forward, out of the tube.

##### CAUTION

Turn the INTENSITY control to minimum when applying power to a new CRT. The phosphor can be damaged quickly by too much brightness.

The CRT can be replaced without removing the instrument cabinet. To replace the cathode-ray tube, refer to Figures 2-9 and 2-10 and proceed as follows:

- a. Loosen the clamp on the CRT socket.
- b. Remove the five clip leads to the deflection-plate and accelerator terminals on the neck of the CRT. If necessary, rotate tube to gain access to the terminals.
- c. Remove the front-panel bezel (see Figure 2-9).

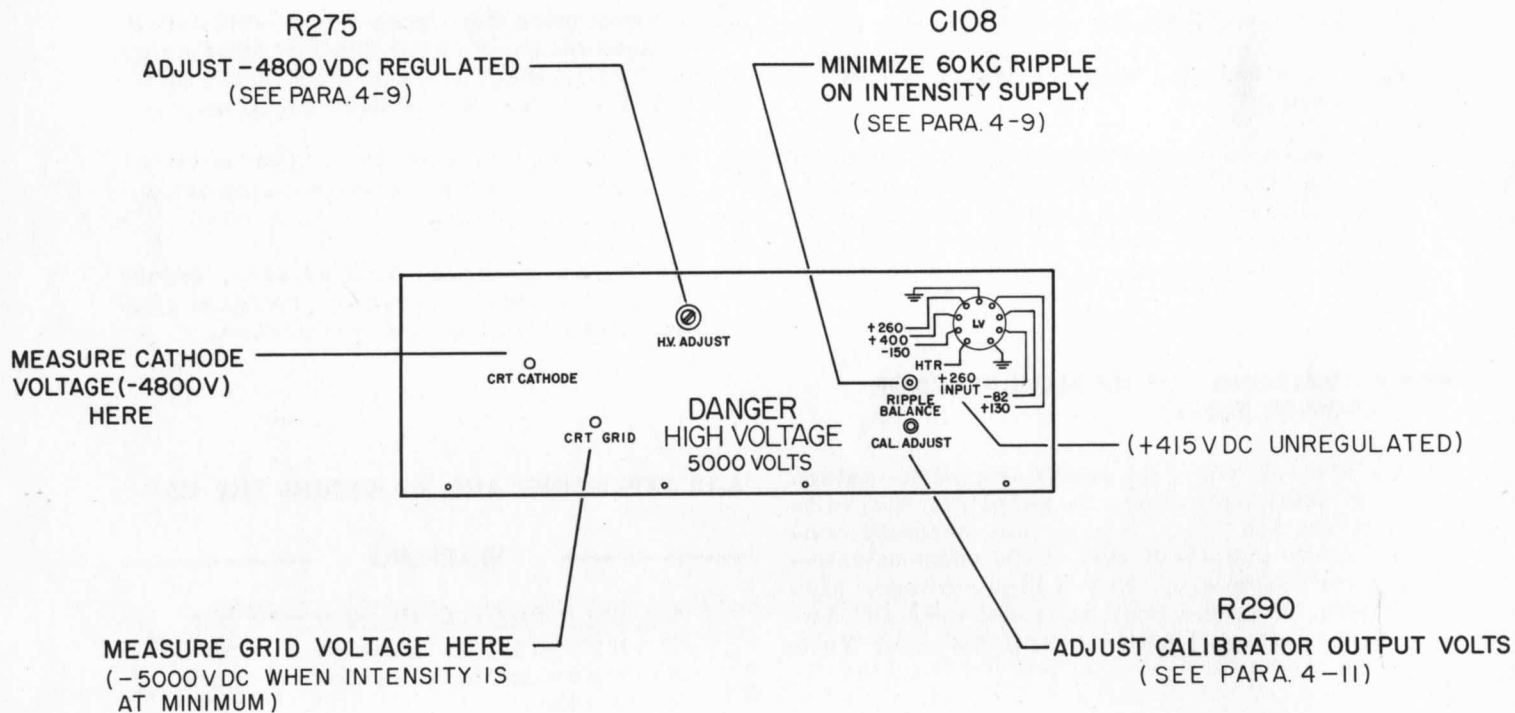

FIGURE 4-4

- d. Grasp the CRT base and, using the alignment lever as a fulcrum, work the CRT base free of the socket.
- e. Remove the CRT through the front panel.
- f. Insert the replacement CRT through the front panel and connect to socket.
- g. Replace front-panel bezel.
- h. Position the socket assembly so that the face of the CRT is seated on the bezel. Reconnect the five deflection-plate and accelerator leads.
- i. Set the INTENSITY control to Max. CCW position. Turn the instrument on and allow to warm up.
- j. Set SWEEP MODE control to FREE RUN.
- k. Adjust the INTENSITY control to obtain a weak trace; adjust the FOCUS control for a sharp trace, and with the vertical position control, center the trace vertically.
- l. Align trace with graticule (see Figure 2-10).
- m. Making certain the CRT face is against the bezel, tighten the clamp on the CRT socket.
- n. To readjust the astigmatism control, connect the CALIBRATOR output to the vertical input.
- o. Set the VOLTS/CM and CALIBRATOR selectors to obtain approximately 6 cm deflection.
- p. Simultaneously adjust the focus and the astigmatism for the best overall focus, or for optimum sharpness in any desired area.
- q. Check the gain calibration of the Main Vertical and Main Horizontal Amplifiers. Paragraphs 4-17 and 4-12.

#### 4-11 ADJUSTING THE CALIBRATOR

The output voltage from the CALIBRATOR is approximately a 1000-cycle/sec. square wave which is 0 volts during the off period and +100 volts peak during the on period when set for

100 volts. The peak positive voltage is set by a screwdriver adjusted potentiometer located on the High-Voltage Regulator deck (see Figure 4-4). This peak positive voltage can be measured with a d-c voltmeter when V32 is removed.

To measure and adjust the 100-volt, CALIBRATOR output, refer to Figure 4-4 and proceed as follows:

- a. Remove the 150A from the cabinet; turn on and allow to warm up for 5 minutes.
- b. Set the CALIBRATOR selector to the 100 volt position.
- c. Connect an accurate d-c voltmeter to the CALIBRATOR output.
- d. Remove V32. If necessary, adjust R290 to obtain exactly +100 vdc at the CALIBRATOR output connector. If the d-c voltage cannot be brought to 100 volts, check the +130- and the -150-volt supplies. If the voltage is still too high, replace crystal diode CR1.
- e. Replace V32.

#### 4-12 ADJUSTING THE MAIN HORIZONTAL AMPLIFIER

The Main Horizontal Amplifier contains the following screwdriver adjustments located on the Horizontal Amplifier (left-side) swing-out chassis:

- 4-12a. Main Horizontal Gain Adjustment
- 4-12b. X100 Magnification Calibration
- 4-12c. X5 Magnification Centering and X1 Centering
- 4-12d. Main Horizontal Amplifier Frequency Response Adjustments

#### 4-12A MAIN HORIZONTAL GAIN ADJUSTMENT

Before adjusting the main horizontal gain check and if necessary adjust the astigmatism control as instructed in paragraph 4-19.

The gain of the Main Horizontal Amplifier is adjusted by potentiometer R199 and should be

# HORIZONTAL AMPLIFIER

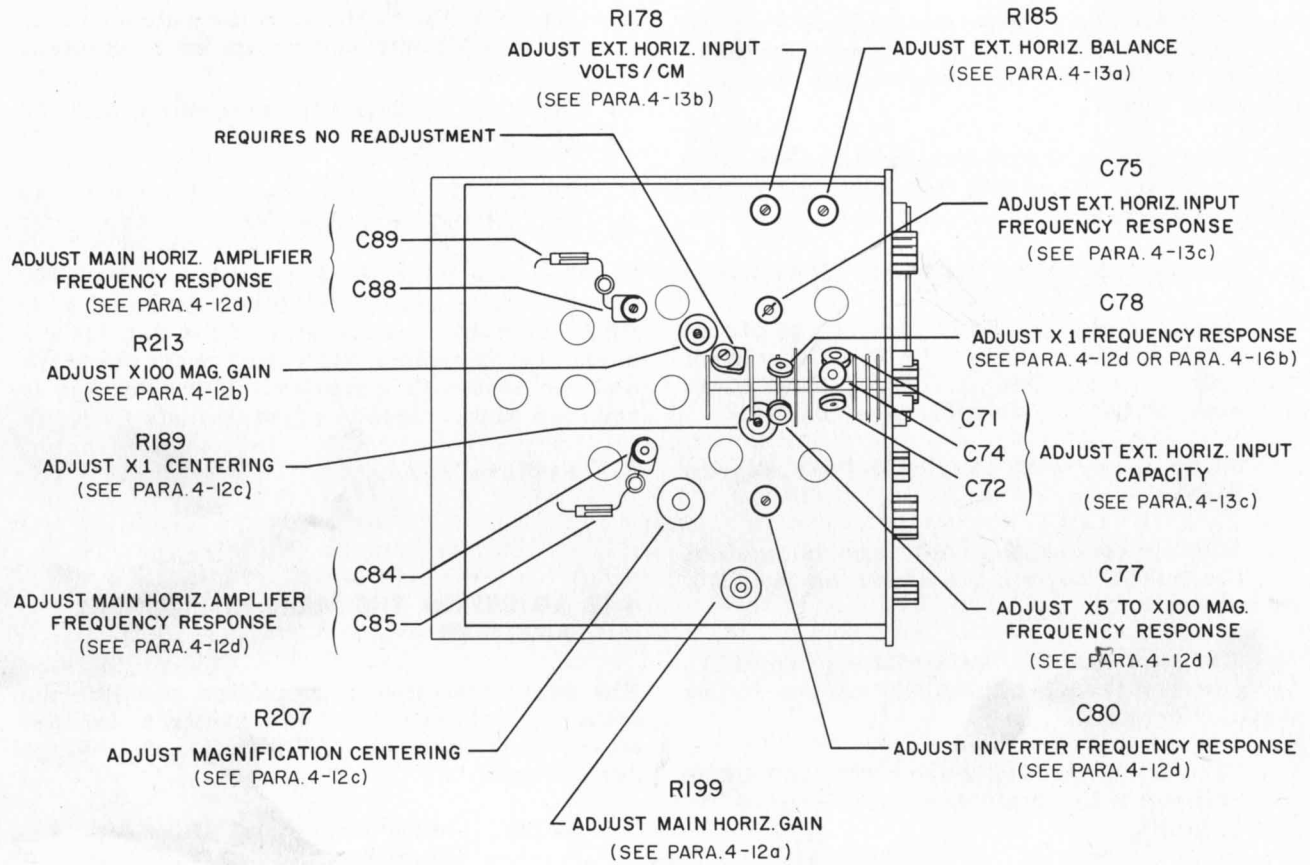

FIGURE 4-5



set to produce an initial deflection sensitivity of 10 volts/centimeter when the HORIZ. SENSITIVITY selector is set to the X1 MAGNIFICATION position. When R199 is adjusted, Inverter Frequency Response adjustment C80 is also affected, and the frequency response must be checked and adjusted as shown in paragraph 4-12d. To adjust the Main Horizontal Amplifier Gain, refer to Figure 4-5 and proceed as follows:

- a. Pull the 150A approximately 5 inches out of the cabinet; turn on and allow to warm up for five minutes.
- b. Set the CALIBRATOR selector to the 20 volt position. Connect the CALIBRATOR output to both the EXT. HORIZ. INPUT and EXT. SYNC INPUT connectors.
- c. Connect the SAWTOOTH OUTPUT inside the top access door to the vertical INPUT A connector.
- d. Set the INPUT A VOLTS/CM selector to the 5 VOLTS/CM position; set the HORIZ. SENSITIVITY selector to the straight down position midway between the X100 MAGNIFICATION and the 5 VOLT/CM positions; set the SWEEP TIME/CM selector to the .5 MILLISECOND/CM position.
- e. Adjust the TRIGGER LEVEL control to give a stable trace. Several cycles of square wave should now be presented vertically on the 150A scope screen.
- f. Adjust the Main Horiz. Gain Adj. R199 to obtain exactly 10 centimeters horizontal deflection for the 20-volt peak-to-peak input.
- g. Check frequency response as shown in paragraph 4-12d.
- h. Adjust the X5 to X100 and the X1 Centering adjustments as shown in paragraph 4-12c.

The basic gain of the Horizontal Amplifier is now correctly set. If the overall calibration of the SWEEP TIME/CM selector is no longer correct, the Sweep Generator is in need of adjustment, see paragraph 4-16.

#### 4-12B X100 MAGNIFICATION CALIBRATION

The X100 range of the INT. SWEEP MAGNIFICATION selector is the only range that has a calibration adjustment; however, this adjustment also affects the X50 and X10 ranges

to lesser degrees. On the X100 range, the sensitivity of the Horizontal Amplifier should be just 100 times the X1 sensitivity of .1 CM/VOLT, or 10 CM/VOLT, and is set by adjustment of potentiometer R213. The CALIBRATOR output can be used for this adjustment. To calibrate the X100 MAGNIFICATION range of the HORIZ. SENSITIVITY selector, refer to Fig. 4-5 and proceed as follows:

- a. Pull the 150A approximately 5 inches out of the cabinet; turn on and allow to warm up for five minutes.
- b. Set the CALIBRATOR selector to the 1 VOLT position.
- c. Note the single grey wire that connects between the Sweep Generator swing-out chassis and the Horizontal Amplifier swing-out chassis. Disconnect this lead from the pin connector on the Horizontal Amplifier etched board. Connect a jumper from the CALIBRATOR output to this board connection.
- d. Also, connect the CALIBRATOR output to the EXT. SYNC INPUT connector.
- e. Connect the SAWTOOTH OUTPUT inside the top access door to the vertical INPUT A connector.
- f. Set the vertical INPUT A VOLTS/CM selector to the 5 VOLTS/CM position; set the HORIZ. SENSITIVITY selector to X100 MAGNIFICATION position; set SWEEP TIME/CM to .5 MILLISECONDS/CM position; set the SWEEP MODE control to PRESET.
- g. Adjust the TRIGGER LEVEL control to give a stable trace. Several cycles of square wave should now be presented vertically on the 150A scope screen.
- h. Adjust the X100 Magnification Gain Adj. R213 to obtain exactly 10 centimeters peak-to-peak horizontal deflection.
- i. Check magnification obtained on the X50 range. If necessary, refine the adjustment of R213 to obtain best overall accuracy.

#### 4-12C X5 TO X100 MAGNIFICATION CENTERING AND X1 CENTERING

The MAGNIFICATION centering adjustments position the spot at the center of the screen when the cathodes of V20 and V21 are at equal potentials. This assures that when the sweep

is magnified, the center of the original trace remains in the center of the screen. The X5 to X100 Magnification Centering Adj. R207 affects all positions of the SWEEP MAGNIFICATION selector. The X1 Centering Adj. R189 readjusts the centering in the X1 position only, and must be set after R207 is correctly set. To make these adjustments refer to Figure 4-5 and proceed as follows:

- a. Remove the 150A from the cabinet; turn on and allow to warm up for five minutes.
- b. Adjust the FOCUS, INTENSITY and SWEEP MODE controls to give a small undeflected spot on the 150A screen.
- c. While repeatedly switching the HORIZ. SENSITIVITY selector from X5 to X100 positions and back, adjust the HORIZ. POSITION control until the spot does not change position as the HORIZ. SENSITIVITY selector is switched. Do not disturb this setting of the HORIZ. POSITION control.
- d. Set the HORIZ. SENSITIVITY selector to the X5 MAGNIFICATION position.
- e. Adjust the X5 to X100 Magnification Centering Adj. R207 to center the spot on the screen. Do not disturb this setting of the HORIZ. POSITION control. If the range of R207 is not sufficient to center the spot, interchange V20 and V21 or V23 with V24 and repeat step e.
- f. Set the HORIZ. SENSITIVITY selector to X1 position.
- g. Adjust the X1 Centering Adj. R189 to center the spot on the screen.

#### 4-12D MAIN HORIZONTAL AMPLIFIER FREQUENCY RESPONSE ADJUSTMENT

The linearity of the oscilloscope sweep requires complete and accurate adjustment of the Main Horizontal Amplifier Frequency Response. The frequency-response adjustments are made by viewing square waves of three different frequencies and requires a square-wave generator with risetimes of .02 microsecond or better and an output of at least 7 volts peak-to-peak. At each of the three test frequencies, adjustments are made to achieve flatness of the top and bottom of the square-wave viewed on the scope screen. Since the Main Horiz. Gain Adj. has some effect upon the frequency response of the amplifier, it should be correctly set as instructed in paragraph 4-12a before the frequency response

is adjusted. To adjust the frequency response of the Main Horizontal Amplifier, refer to Figure 4-5 and proceed as follows:

- a. Connect SWEEP OUTPUT of 150A to vertical INPUT.
- b. Connect the "75 $\mu$ " output of an  $\text{Gp}$  Model 211A Square Wave Generator to pin 1 of V20 through a 0.1  $\mu$ f, 600 volt capacitor. This connection can be made at the junction of R204 and R187. Resistor R187 is connected to the Horizontal Position control and is located directly behind this control.

Connect the "600 $\mu$ " output of the 211A to the EXT. SYNC. INPUT of the 150A under test.

- c. Set oscilloscope POLARITY switch to "AC POS. UP".
- d. Set oscilloscope SYNC control to "EXT. AC" and SWEEP MODE to "PRESET".
- e. Set vertical VOLTS/CM at "1" and VERNIER at "CAL".
- f. Set Square Wave Generator to 100 KC.
- g. Switch oscilloscope HORIZ. SENSITIVITY control to "X5".
- h. Locate "Sweep Output" connector on Sweep Generator Board. This point is most easily located as the connector with a gray wire at pin 7 of tube V13. Disconnect gray wire at this connector.
- i. Set the 211A controls to obtain a horizontal deflection of approximately 8 centimeters. Use a sweep speed that will permit viewing two or three cycles.
- j. Adjust C84 and C88 followed by C85 and C89 plus C80 to obtain the best possible square wave pattern. Capacitors C84 and C88 control one time constant, C85 and C89 a second time constant, and C80 a third time constant.

The waveforms obtained will vary with input frequency. Some high frequency ringing will be noted but should be disregarded when making these adjustments.

The following procedure is recommended:

1. Set capacitors C84 and C88 to the center of their adjustment range so they are set to approximately equal values.

2. Adjust for the best possible square wave pattern by rotating C84 and C88 each approximately the same amount to keep both capacitors as close to the same value as possible.
  3. Adjust capacitors C85 and C89 plus C80 for the best possible square wave pattern. Capacitors C85 and C89 are formed by metal straps around encapsulated resistors R219 and R224 respectively. Adjust by sliding straps along encapsulated resistors.
- k. Set the HORIZ. SENSITIVITY selector to "X10". Reduce the "75 $\mu$ " output from the 211A generator to obtain a horizontal deflection of approximately 8 centimeters. The 211A should be set to 100 KC.
  - l. Adjust capacitor C86 to obtain the best possible square wave pattern. Disregard any ringing present when making this adjustment.
  - m. Reconnect the wire disconnected in step h.
  - n. Disconnect the "75 $\mu$ " output of the 211A from pin 1 of V20, remove the 0.1  $\mu$ f capacitor used in step 2, and reconnect the "75 $\mu$ " output directly to the "EXT. HORIZ. INPUT". Set the 211A to 10 KC.
  - o. Switch the HORIZ. SENSITIVITY selector to the unmarked vertical test position. Set the 211A controls to obtain maximum horizontal deflection which will be approximately 4 centimeters. Use a sweep speed that will permit viewing two or three cycles.
  - p. Adjust capacitor C77 to obtain the best possible square wave.

#### 4-13 ADJUSTING THE EXT. HORIZ. INPUT PREAMPLIFIER

The External Horizontal Input Preamplifier contains the following screwdriver adjustments located on the Horizontal Amplifier swing-out chassis. These adjustments should not be attempted unless the gain and frequency response of the Main Horizontal Amplifier are known to be correctly adjusted.

- 4-13a. External Balance Adjustments
- 4-13b. External Horizontal Input Sensitivity Calibration
- 4-13c. External Horizontal Input Capacity and Frequency Response Adjustments

#### 4-13A HORIZ. BALANCE ADJUSTMENT

Adjustment of the horizontal Ext. Bal. Adj. potentiometer R185 minimizes shifts in horizontal centering when the VERNIER control is varied. To adjust the Ext. Bal. Adj. refer to Figure 4-5 and proceed as follows:

- a. Remove the 150A from the cabinet; turn on and allow to warm up for five minutes.
- b. Set the HORIZ. SENSITIVITY selector to the .2 VOLTS/CM range. Adjust the HORIZ. POSITION and the INTENSITY controls to obtain a spot of medium intensity.
- c. While turning the horizontal VERNIER control up and down repeatedly, adjust the Ext. Bal. Adj. potentiometer R185 until the spot does not move as the VERNIER control is moved.

#### 4-13B EXT. HORIZ. INPUT VOLTS/CM CALIBRATION

The Ext. Gain Adj. potentiometer R178 sets the gain of preamplifier tube V18 to calibrate the EXT. INPUT VOLTS/CM positions of the HORIZ. SENSITIVITY selector switch. To make this adjustment, refer to Figure 4-5 and proceed as follows:

- a. Perform steps a through d of paragraph 4-13a, above.
- b. Set the CALIBRATOR selector to the 2 VOLT position and connect the CALIBRATOR output to the EXT. SYNC INPUT.
- c. Connect the SAWTOOTH OUTPUT in the top access to the input of the plug-in vertical amplifier.

# SWEEP GENERATOR

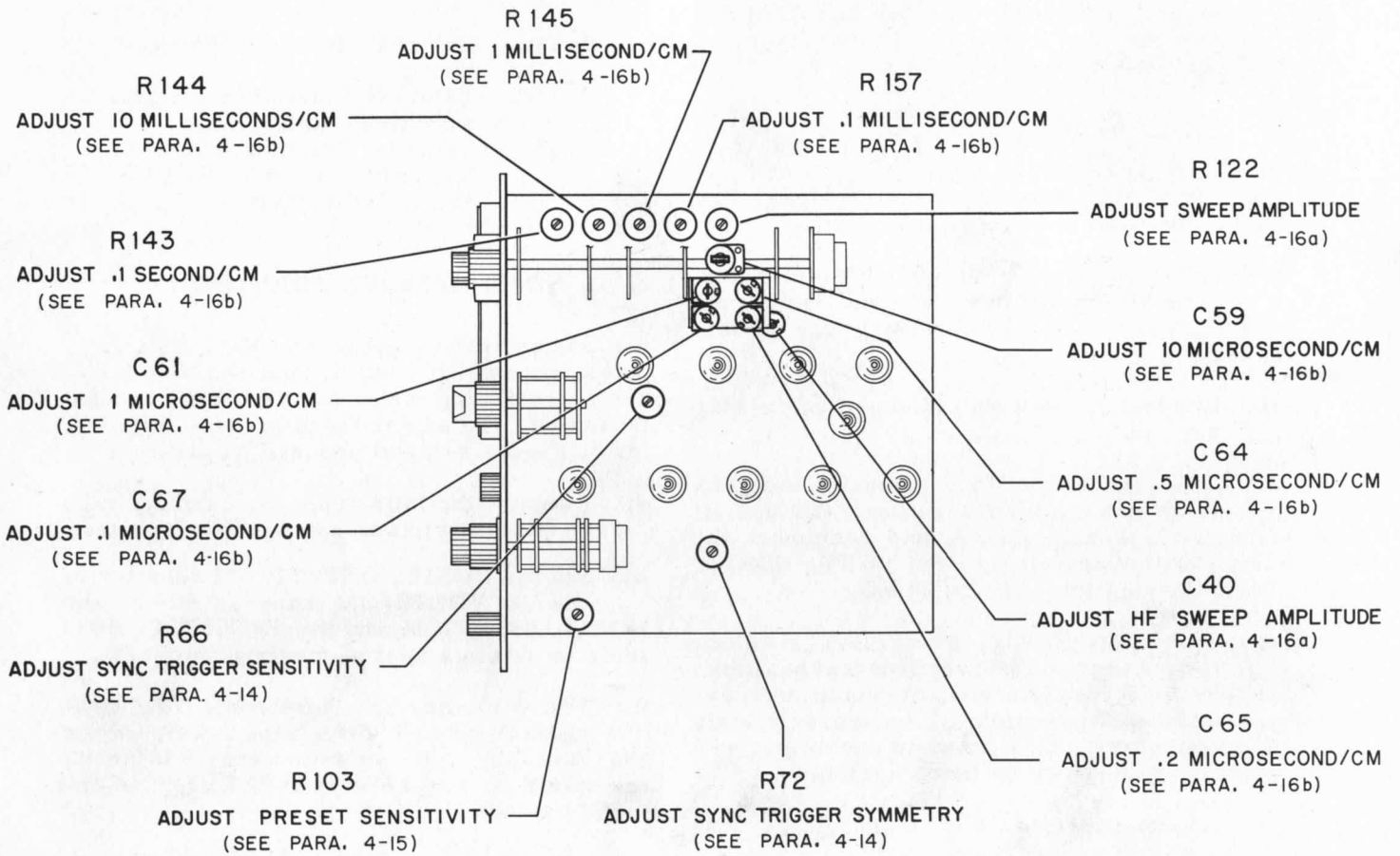

FIGURE 4-6

- d. Set the vertical VOLTS/CM selector to 2 VOLTS/CM; set the SWEEP TIME/CM selector to 1 MILLISECOND/CM; set the SWEEP MODE control to PRESET; set the SYNC selector to EXT; set the HORIZ. SENSITIVITY selector to .2 VOLTS/CM. Adjust the TRIGGER LEVEL control to obtain a stable trace.
- e. Connect the CALIBRATOR output to the EXT. HORIZ. INPUT.
- f. Set the EXT. HORIZ. INPUT VERNIER control to the CAL. position.
- g. Adjust the Ext. Gain Adj. potentiometer R178 to obtain a square wave amplitude of 10 centimeters, disregarding overshoot, if present.

#### 4-13C EXT. HORIZ. INPUT CAPACITY AND FREQUENCY RESPONSE ADJUSTMENT

The EXT. INPUT VOLTS/CM section of the HORIZ. SENSITIVITY selector switch has two adjustments for frequency response, C72 and C75, and two adjustments for standardizing the input capacitance, C71 and C74.

The two frequency response adjustments flatten the response of two different attenuator networks. The two input capacity adjustments equalize the EXT. HORIZ. INPUT capacity with the vertical INPUT A and B capacity so that the 10:1 divider probe can be used interchangeably with either input without readjustment of the probe. To make these adjustments, refer to Figure 4-5 and proceed as follows:

- a. Remove the 150A from the cabinet; turn on and allow to warm up for five minutes.
- b. Set the CALIBRATOR selector to the 5 VOLT position and connect the CALIBRATOR output to the EXT. SYNC INPUT.
- c. Connect the SAWTOOTH OUTPUT in the top access door to the vertical INPUT A.
- d. Set the vertical INPUT A VOLTS/CM selector to the 2 VOLTS/CM position; set the SWEEP TIME/CM selector to the .5 MILLISECONDS/CM position; set the SWEEP MODE control to PRESET; set the SYNC selector to EXT. Adjust the TRIGGER LEVEL control to obtain a stable vertical trace.
- e. Connect the CALIBRATOR output to the EXT. HORIZ. INPUT. Set the HORIZ. SENSITIVITY selector to the .5 VOLTS/CM

position. Several cycles of square wave should now be displayed vertically on the 150A scope screen.

- f. Adjust C75 for the straightest top and bottom on the square wave.
- g. Replace the connection from the CALIBRATOR output to the EXT. HORIZ. INPUT with the AC-21 Probe which has been adjusted for use with the 150A's vertical amplifier.
- h. Set the CALIBRATOR output to the 50 VOLT position.
- i. Adjust C74 for the straightest top and bottom on the square wave as viewed on the 150A scope screen.
- j. Set the HORIZ. SENSITIVITY selector to the 2 VOLTS/CM position. Increase the CALIBRATOR output voltage to obtain a square-wave amplitude of several centimeters.
- k. Adjust C71 and C72 to obtain the straightest top and bottom of the square wave as viewed on the 150A scope screen. C71 and C72 affect widely differing time constants such that their separate effects are easily distinguished.

#### 4-14 ADJUSTING THE SYNC CIRCUIT

The Sync Circuit has three interdependent adjustments; calibrating the zero position of the TRIGGER LEVEL control; adjusting Trigger Sensitivity; adjusting Trigger Symmetry. All three must be adjusted in one procedure.

Calibrating the zero position of the TRIGGER LEVEL control equalizes the d-c voltage level from the two plates of Phase Inverter V8 when the TRIGGER LEVEL is set to "0". Adjusting the Trigger Sensitivity establishes the minimum input sync signal voltage which will operate Schmitt Trigger V9. Adjusting Trigger Symmetry adjusts the Schmitt Trigger to have equal sensitivity to both positive and negative going signals, i.e., it adjusts the hysteresis area of V9 so that the upper and lower limits can be positioned symmetrically about the d-c bias level obtained from V8 with the TRIGGER LEVEL set to zero. To adjust the Sync Circuits, refer to Figure 4-6 and proceed as follows:

- a. Remove the 150A from the cabinet; turn on and allow to warm up for 5 minutes.

- b. Connect a d-c VTVM (isolated from chassis) to pins 1 and 6 (plates) of V8.
- c. Set the TRIGGER LEVEL control to obtain 0 volts on the voltmeter.
- d. If necessary, loosen the set screw and position the TRIGGER LEVEL knob to indicate 0 (top center) when the difference voltage as read on the voltmeter is zero. Remove the meter. Do not disturb the setting of the TRIGGER LEVEL control.
- e. Connect an audio oscillator to the SYNC INPUT connector. Adjust oscillator to be between 20 and 50 kilocycles.
- f. Connect a test oscilloscope, calibrated to give a 1 volt/centimeter vertical deflection, to pin 2 (grid) of V9.
- g. Adjust the oscillator output to obtain a 4-cm deflection on the test oscilloscope and adjust the scope sweep to observe four complete cycles on the screen. One pip should appear on each slope of the sine wave. The upper pip is the upper hysteresis limit, and should be on the positive slope of the sine wave; the lower pip is the lower limit, and should be on the negative slope of the sine wave.
- h. If necessary, adjust R66 to obtain a "hysteresis" area exactly 1 centimeter wide.
- i. If necessary, adjust R72 to position the hysteresis area exactly midway between the top and bottom of the sine waves.
- j. The two adjustments, R66 and R72, interact and must be repeated until both the hysteresis area and the position are correct.

#### 4-15 ADJUSTING THE PRESET SENSITIVITY OF THE SWEEP GENERATOR

The PRESET position of the SWEEP MODE control provides a fixed sensitivity for the Sweep Start-Stop Trigger which gives stable triggering for almost all sync signals. The sensitivity of the Sawtooth Generator is determined by the bias applied to the control grid of V10A; the more positive the bias voltage, the larger the sync signal required to trigger V10. The SWEEP MODE control adjusts this bias, and in the PRESET position, supplies an optimum fixed bias voltage. To adjust the PRESET sensitivity, refer to Figure 4-6 and proceed as follows:

- a. Remove the 150A from the cabinet; turn on and allow to warm up for 5 minutes.
- b. Set SWEEP TIME on .1 MILLISECOND/CM, SWEEP MODE on PRESET.
- c. While measuring the d-c voltage at pin 2 of V10, turn the SWEEP MODE control clockwise from the PRESET position until the Sawtooth Generator free runs. At the moment the generator begins to free run, the voltage reading will suddenly drop. Note exact voltage reading before the drop.
- d. Set the SWEEP MODE control to PRESET. Note the voltmeter reading. If necessary, adjust R103 to obtain a reading that is exactly 1.5 volts less negative than obtained in step d.

#### 4-16 CALIBRATING THE SWEEP GENERATOR

Calibrating the Sweep Generator includes one adjustment for Sweep Amplitude located in the Sweep Generator, and one fine adjustment for Sweep Slope located in the Main Horizontal Amplifier. Do not attempt the Sweep Slope Adjustments unless the Sweep Amplitude (para. 4-16a), the Main Horizontal Gain (para. 4-12a) and the Main Horizontal Frequency Response (para. 4-12d) are known to be correct. For the Slope Adjustments a crystal-controlled time-mark generator is required.

- 4-16a. Sweep Amplitude Adjustment
- 4-16b. Sweep Slope Adjustments

#### 4-16A SWEEP AMPLITUDE ADJUSTMENT

This adjustment is made by adjusting the Sweep Amplitude Adj. potentiometer R122 to give a sawtooth amplitude of -112 volts. Correct setting of this adjustment, and C40, the 0.2 microsecond Sweep Amplitude adjustment, assures that a properly adjusted Horizontal Amplifier will produce 11 centimeters of Sweep deflection. To make this adjustment, refer to Figure 4-6 and proceed as follows:

- a. Remove the 150A from the cabinet; turn on and allow to warm up for five minutes.
- b. Connect a d-c voltmeter having an

accuracy of 3% or better between pin 8 of V15 and ground.

- c. Set the SWEEP TIME/CM selector to the 1 SECOND/CM position; set the SWEEP MODE control to ccw position but not on PRE-SET.
- d. Record the voltmeter reading. This reading may be a few volts positive or negative.
- e. Set the SWEEP MODE control to FREE RUN.
- f. Observe the most negative voltage reading on the meter.
- g. If necessary, adjust R122 to make this voltage 112 volts more negative than the reading in step d.
- h. Set the SWEEP TIME/CM selector to the .2 microsecond range and adjust C40 to obtain 11 cm deflection.

#### 4-16B SWEEP SLOPE ADJUSTMENT

The Sweep Generator contains nine independent adjustments, R143, R144, R145, R157, C41, C59, C64, C65, and C67 which calibrate the sawtooth sweep for nine groups of ranges of the SWEEP TIME/CM selector. A tenth adjustment, C78 in the Horizontal Amplifier, is used only for the fastest sweep position. To make these adjustments, refer to Figure 4-6 and proceed as follows:

- a. Remove the 150A from the cabinet; turn on and allow to warm up for five minutes.
  - b. Set SWEEP/CM to ".1 MILLISECOND", sweep VERNIER to "CAL.", SYNC to "INT", SWEEP MODE to "PRESET", and HORIZ. SENSITIVITY to "X1".
  - c. Connect the output from a marker generator to the oscilloscope vertical input.
  - d. Set the marker generator for pips spaced 100 microseconds apart.
  - e. Adjust oscilloscope vertical VOLTS/CM, TRIGGER LEVEL, and TRIGGER SLOPE controls to obtain a steady trace.
  - f. Adjust R157 so pips are exactly 1 centimeter apart.
  - g. Set marker generator to 5 microseconds.
  - h. Set HORIZ. SENSITIVITY switch to "X5", "X10", "X50", and "X100" which should produce pips spaced 0.25, 0.5, 2.5, and 5 centimeters apart respectively. Return switch to "X1".
- If expanded sweep ranges are out of calibration, set HORIZ. SENSITIVITY to "X100" and adjust R213, mounted on Horizontal Amplifier deck, to space pips exactly 5 centimeters apart.
- i. Set marker generator for 1 millisecond pips and SWEEP TIME/CM to ".2 MILLI-SECOND". The pips should be exactly 5 centimeters apart.
  - j. Set SWEEP TIME/CM to ".5 MILLI-SECOND". The pips should be exactly 2 centimeters apart.
  - k. Set SWEEP TIME/CM to "1 MILLI-SECOND". Adjust R145 to set pips exactly 1 centimeter apart.
  - l. Set marker generator for 10 millisecond pips.
  - m. Switch SWEEP TIME/CM to "2 MILLI-SECONDS" and then "5 MILLI-SECONDS" which should produce pips spaced exactly 5 and 2 centimeters apart respectively.
  - n. Set SWEEP TIME/CM to "10 MILLI-SECONDS" and adjust R144 to set pips exactly 1 centimeter apart.
  - o. Set marker generator for 100 milliseconds (0.1 second) pips.
  - p. Switch SWEEP TIME/CM to "20 MILLI-SECONDS" and "50 MILLI-SECONDS" which should produce pips spaced exactly 5 and 2 centimeters apart respectively.
  - q. Set SWEEP TIME/CM to ".1 SECOND" and adjust R143 to set pips exactly 1 centimeter apart.
  - r. Set marker generator for 1 second pips.
  - s. Set SWEEP TIME/CM to ".2 SECOND", ".5 SECOND", and "1 SECOND" which should produce pips spaced exactly 5, 2, and 1 centimeters apart respectively.
  - t. Set SWEEP TIME/CM to "2 SECONDS" and "5 SECONDS" which will produce 2 pips and 5 pips per centimeter respectively.
  - u. Set SWEEP TIME/CM to "20 MICRO-SECONDS", HORIZ. SENSITIVITY to "X5", and SWEEP MODE full clockwise to "FREE RUN".

- v. Set marker generator for a 10 MC sine wave. Adjust oscilloscope controls to obtain a steady display 5 to 6 centimeters high.
- w. Adjust C67 so two cycles of the sine wave are 10 centimeters long.
- x. Set HORIZ. SENSITIVITY to "X1".
- y. Adjust C78 on the Horizontal Amplifier deck to space marker pips exactly 1 centimeter apart. If the sweep length is less than 10 centimeters.
  - 1. Disconnect any input to oscilloscope vertical amplifier or EXT. SYNC. INPUT terminals.
  - 2. Set SWEEP TIME/CM switch to ".1 MICROSECOND", sweep VERNIER to "CAL.", HORIZ. SENSITIVITY to "X1", and rotate SWEEP MODE control full clockwise.
  - 3. Set sweep length by adjusting C40 to obtain a horizontal line 10.4 centimeters long.
  - 4. A test oscilloscope can be used to make a refinement of the adjustment made in step 3. Connect the oscilloscope to pin 8 of tube V15 through a low capacity probe and observe the sweep generator waveform. Adjust C40 just short of the position that produces distortion of the waveform at the maximum negative point. Distortion, if permitted, will produce sweep "fold-over" at the end of the sweep.
- z. Set marker generator for a 5 MC sine wave.
  - aa To adjust .2 and .5 MICROSECOND sweeps:
    - 1. Set SWEEP TIME/CM to ".2 MICROSECOND" and adjust C65 to make 10 cycles of the sine wave 10 centimeters long.
    - 2. Set marker generator for 1 microsecond pips.
    - 3. Set SWEEP TIME/CM to ".5 MICROSECOND" and adjust C64 so that 5 cycles from the marker generator are 10 centimeters long.
  - ab Set SWEEP TIME to "1 MICROSECOND" and set marker generator for 1 microsecond pips.
  - ac Adjust capacitor C61 to set pips exactly 1 centimeter apart.
  - ad Set marker generator for 10 microsecond pips.
  - ae Set SWEEP TIME/CM to "2 MICROSECONDS" and "5 MICROSECONDS" which will give pips spaced 5 and 2 centimeters respectively.
  - af Set SWEEP TIME/CM to "10 MICROSECONDS" and adjust C59 to set pips exactly 1 centimeter apart.
  - ag Set marker generator for 100 microsecond pips.
  - ah Set SWEEP TIME/CM to "20 MICROSECONDS" and "50 MICROSECONDS" which should produce pips spaced exactly 5 and 2 centimeters apart respectively.



# MAIN VERTICAL AMPLIFIER

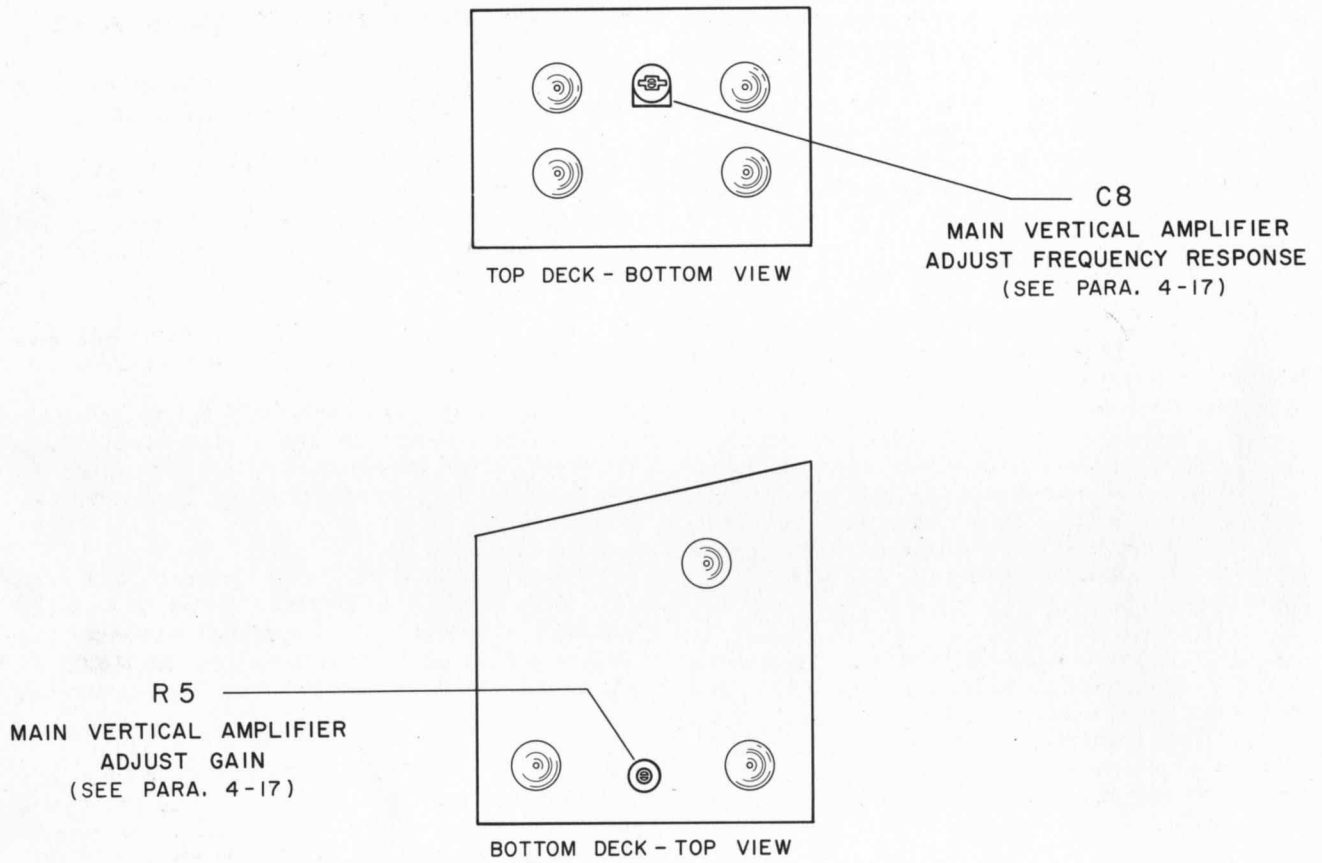

FIGURE 4-7

#### 4-17 ADJUSTING GAIN AND FREQUENCY RESPONSE OF MAIN VERTICAL AMPLIFIER

The Gain setting of the Main Vertical Amplifier is a simple potentiometer adjustment which standardizes the gain of the Main Vertical Amplifier on the instrument chassis so that any plug-in amplifier may be used in any 150A without losing deflection calibration. The adjustment requires only an a-c voltmeter calibrated in rms volts. The frequency response adjustments are screwdriver-adjusted trimmer capacitors which are easily adjusted by observing on the oscilloscope screen a 100-KC and 1-MC square wave applied to the oscilloscope input. To standardize the gain of the Main Vertical Amplifier, refer to Figure 4-7 and proceed as follows:

- a. Remove the 150A from the cabinet; turn on and allow to warm up for 5 minutes.
- b. Connect the CALIBRATOR output to the vertical INPUT connector on the plug-in amplifier being used. Synchronize the oscilloscope internally.
- c. Connect an a-c voltmeter such as the  $\text{hp}$  Model 400 series to the push-pull input connections of the Main Vertical Amplifier. The voltmeter must be isolated from chassis ground to prevent shorting out one side of the input signal.
- d. Adjust the CALIBRATOR and the vertical VOLTS/CM selector and VERNIER to obtain a voltmeter reading of exactly 1.65 volts. Note that an average reading voltmeter calibrated in rms volts of a sine wave reads 1.65 volts for the 3-volt peak-to-peak square wave used.
- e. If necessary, adjust R5 to obtain an exact 6-centimeter vertical deflection on the oscilloscope graticule. Gain standardization is complete. To set the frequency response, proceed as follows:
- f. Connect a 1 megacycle square wave having rise and decay times not greater than 0.1  $\mu\text{sec}$  to the vertical INPUT connector.
- g. If necessary, adjust C8 to obtain the flattest square wave on the oscilloscope.

#### 4-18 ADJUSTING MODEL 152A DUAL TRACE AMPLIFIER

The Dual Trace Amplifier Unit has the following screwdriver adjustments:

- a. Vertical Centering Adjustment.
- b. Neutralizing Adjustments.
- c. Output Frequency Response Adjustment.
- d. Input Capacity Adjustment.
- e. VOLTS/CM Range Switch Frequency Response Adjustments.

#### 4-18A VERTICAL CENTERING ADJUSTMENTS

The Vertical centering adjustment affects both the A and B INPUTS at the same time.

- a. Remove the air-filter element to gain access to the adjustments; turn on the 150A and allow to warm up for five minutes. Set the SWEEP MODE control to free run to obtain a straight line trace.
- b. Set the VERTICAL PRESENTATION selector for ALTERNATE operation.
- c. Since any unbalance affects the position of the trace it is imperative that each channel be balanced according to the procedure given in the Operating Instructions, Figure 2-11.
- d. Superimpose the two traces with the VERTICAL POSITION knob for each channel set equally on opposite sides of the center of their adjustment range. Adjust R561 as required to center the two traces on the screen.
- e. If the VERTICAL POSITION knobs are not both close to the center of their adjustment range there is a relative unbalance involving tubes V502, V503, V508 and V509. Such an unbalance may be corrected by interchanging or replacing these tubes. Repeat steps c and d.

#### 4-18B NEUTRALIZING ADJUSTMENTS

To prevent the higher frequencies from feeding through the push-pull Output Amplifiers when they are in a turned-off state, these amplifiers must be neutralized. Neutralization is accomplished with trimmer capacitors which are adjusted while observing the leakage of a 10-megacycle signal through the output amplifiers of the channel which is cut-off.

To neutralize the output amplifiers, refer to Fig. 4-8 and proceed as follows:

# DUAL TRACE AMPLIFIER

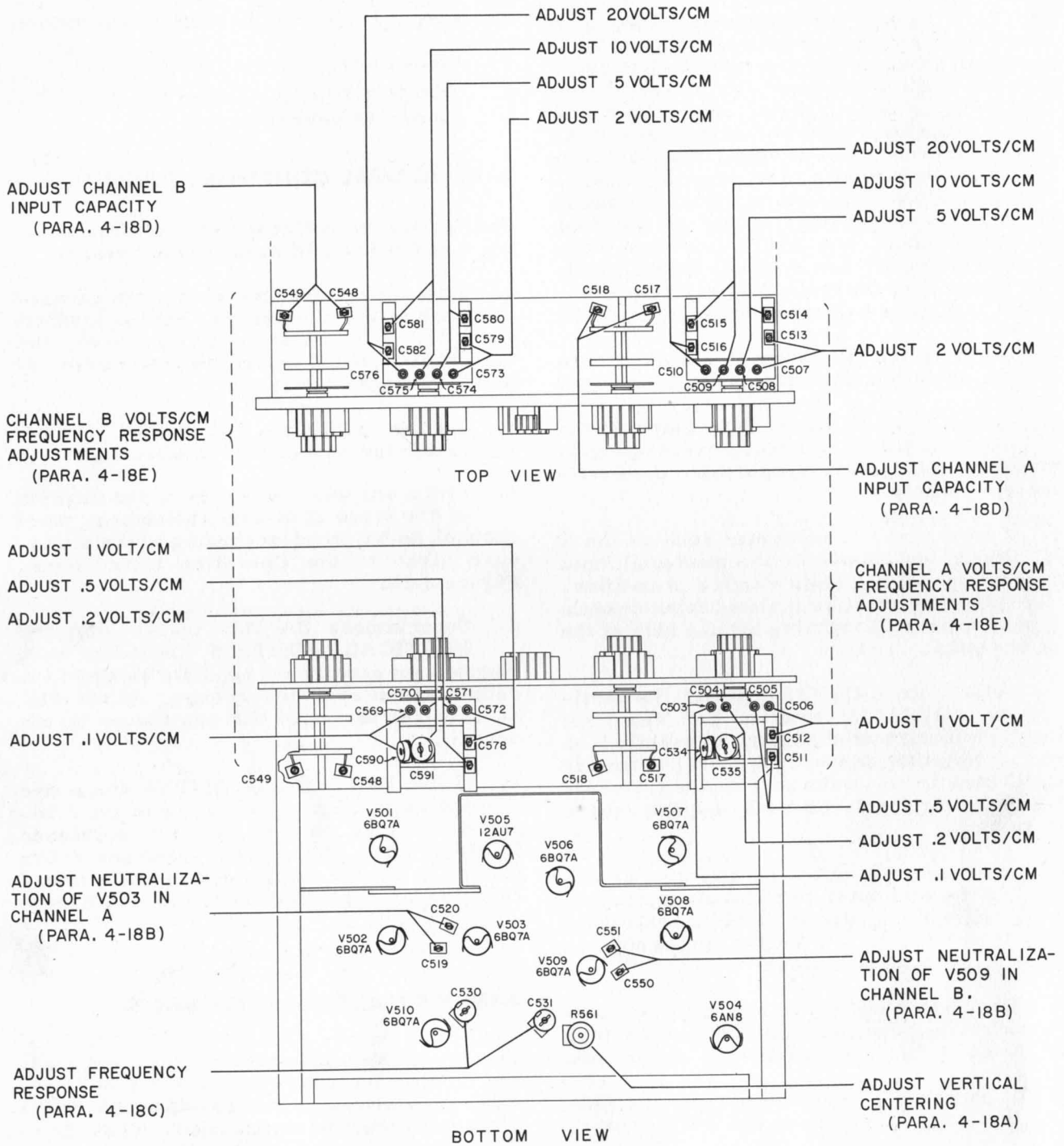

FIGURE 4-8

- a. Remove the air-filter element to gain access to the adjustments; turn on the 150A and allow to warm up for 5 minutes.
- b. Set the SWEEP TIME/CM selector to .5 MICROSECOND/CM position; set the SYNC selector to EXT. AC.
- c. Connect 10-megacycle sine wave signal to INPUT A and to EXT. SYNC INPUT.
- d. Adjust the VOLTS/CM selector to obtain a vertical deflection of 6 centimeters, then set the VOLTS/CM switch to the next more sensitive range.
- e. Set the VERTICAL PRESENTATION selector to B ONLY position.
- f. Simultaneously adjust C519 and C520 to obtain a minimum residual signal on the oscilloscope trace. The two adjustment trimmers should now have nearly equal physical settings. If they do not have nearly equal settings, the switched amplifier tube (V503 or V509) has an undesirable capacity unbalance and should be replaced.
- g. Repeat the above procedure for INPUT B, connecting the 10 MC signal to INPUT B, setting the VERTICAL PRESENTATION selector to the A ONLY position and adjusting C 550 and C551.

#### 4-18C OUTPUT FREQUENCY RESPONSE ADJUSTMENT

To compensate for circuit loading by the input capacity of output cathode followers V510A and B, the grid circuits contain resistance-capacity voltage dividers which utilize the input capacity of the Output Cathode Followers as part of the dividers. The effect is to maintain a constant signal voltage division over the full frequency range.

The time constant of this adjustment is approximately 1.5 microseconds.

To adjust Output Frequency Response trimmers C530 and C531, refer to Figure 4-8, and proceed as follows:

- a. Remove the air-filter element to gain access to the adjustments; turn on the 150A and allow to warm up for five minutes.
- b. Set the VERTICAL PRESENTATION selector for CHOPPED operation; set the

SWEEP TIME/CM selector to the 5 MICRO-SECOND position.

- c. Using the AC-21A Probe connected to the EXT. SYNC. INPUT, synchronize the 150A from the junction of R551, R552, C529.
- d. With the VERTICAL POSITION controls, center both traces.
- e. Connect the 6.3 vac from the CALIBRATOR output to INPUT A.
- f. Set the VOLTS/CM selector to obtain a vertical deflection of 6 centimeters.
- g. Adjust C530 and C531 to obtain the flattest and most stationary Channel B trace.
- h. To assure that the best transient response is obtained, apply a high-quality 100-kilocycle square wave to either Vertical Input. Adjust scope presentation for convenient viewing.
- i. If necessary, refine the adjustment of C530 and C531 equally to obtain flattest top on square wave.

#### 4-18D VERTICAL INPUT CAPACITY ADJUSTMENT

The input capacities of the vertical and horizontal input circuits in *hp* Model 150A oscilloscopes have been made adjustable so that they all can be made equal. A probe that is adjusted for one input is then correctly adjusted for all other inputs. If a tube or other component in the input circuit is changed, it may be necessary to reset the input capacity to the standard amount. To standardize an input capacity requires one input circuit which is known to be correctly adjusted and a probe which has been adjusted to this input, see Fig. 2-8. To standardize the vertical input capacities, refer to Fig. 4-8 and proceed as follows:

- a. Turn on the 150A and allow it to warm up for five minutes.
- b. Connect the standardized probe to INPUT A and to the CALIBRATOR output.
- c. Set the POLARITY selector to POS. UP, the VOLTS/CM selector to .05 and the SYNC selector to INT.
- d. Adjust C517 to obtain the flattest top on the 1 KC square wave.

e. Set the POLARITY selector to NEG. UP and adjust C518 to obtain the flattest top on the square wave.

f. To adjust INPUT B, connect the standardized probe to INPUT B and adjust C548 for POS. UP and C549 for NEG. UP.

#### 4-18E VOLTS/CM SELECTOR FREQUENCY RESPONSE ADJUSTMENTS

Each VOLTS/CM range switch consists of independent resistance-capacity voltage dividers, each section having two adjustments. One capacitor in each dividing network is adjustable to obtain balanced resistance-capacity values and provides constant voltage division over the full frequency range. The other capacitor keeps the input capacity constant. The values of resistance and capacity in the switch are such that the adjustments can be made at relatively low frequencies and the output of the internal CALIBRATOR can be used. These adjustments are dependent upon the correct adjustment of the Vertical Input Capacity (see para. 4-18d). To adjust the frequency response of all ranges of the VOLTS/CM range switch, proceed as follows:

- a. Turn on the 150A and allow to warm up for five minutes.
- b. Connect the CALIBRATOR OUTPUT to the VERTICAL INPUT of the channel to be adjusted by means of a standardized probe.
- c. Set the VOLT/CM selector to the range indicated in the following chart and adjust the CALIBRATOR for a convenient presentation on the oscilloscope screen. Make the indicated adjustments for best square-wave response.

#### NOTE

Model 152A requires two Plug-in Extenders (stock number 150A-95L) so that the 152A can be operated partially withdrawn from the 150A to gain access to some of the adjustments.

VOLTS/CM RANGE	CHANNEL A ADJS.	CHANNEL B ADJS.
.1	C503 C534	C569 C590
.2	C504 C535	C570 C591
.5	C505 C511	C571 C577
1	C506 C512	C572 C578
2	C507 C513	C573 C579
5	C508 C514	C574 C580
10	C509 C515	C575 C581
20	C510 C516	C576 C582

## SCHEMATIC DIAGRAM NOTES

1. Heavy solid line shows main signal path; heavy dashed line shows control, secondary signal, or feedback path.
2. Heavy box indicates front-panel engraving; light box indicates chassis marking.
3. Arrows on potentiometers indicate clockwise rotation as viewed from the round shaft end, counterclockwise from the rectangular shaft end.
4. Resistance values in ohms, inductance in microhenries, and capacitance in micromicrofarads unless otherwise specified.
5. Rotary switch schematics are electrical representations; for exact switching details refer to the switch assembly drawings.
6. Relays shown in condition prevailing during normal instrument operation.

## VOLTAGE AND RESISTANCE DIAGRAM NOTES

1. Each tube socket terminal is numbered and lettered to indicate the tube element and pin number, as follows:

* = no tube element	P = plate
H = heater	T = target (plate)
K = cathode	R = reflector or repeller
G = control grid	A = anode (plate)
Sc = screen grid	S = spade
Sp = suppressor grid	Sh = shield
	NC = no external connection to socket

The numerical subscript to tube-element designators indicates the section of a multiple-section tube; the letter subscript to tube-element designators indicates the functional difference between like elements in the same tube section.

A socket terminal with an asterisk may be used as a tie point and may have a voltage and resistance shown.

2. Voltages values shown are for guidance; values may vary from those shown due to tube aging or normal differences between instruments. Resistance values may vary considerably from those shown when the circuit contains potentiometers, crystal diodes, or electrolytic capacitors.
3. Voltage measured at the terminal is shown above the line, resistance below the line; measurements made with an electronic multimeter, from terminal to chassis ground unless otherwise noted.
4. A solid line between socket terminals indicates a connection external to the tube between the terminals; a dotted line between terminals indicates a connection inside the tube. Voltage and resistance are given at only one of the two joined terminals.

# MAIN VERTICAL AMPLIFIER VOLTAGE - RESISTANCE DIAGRAM

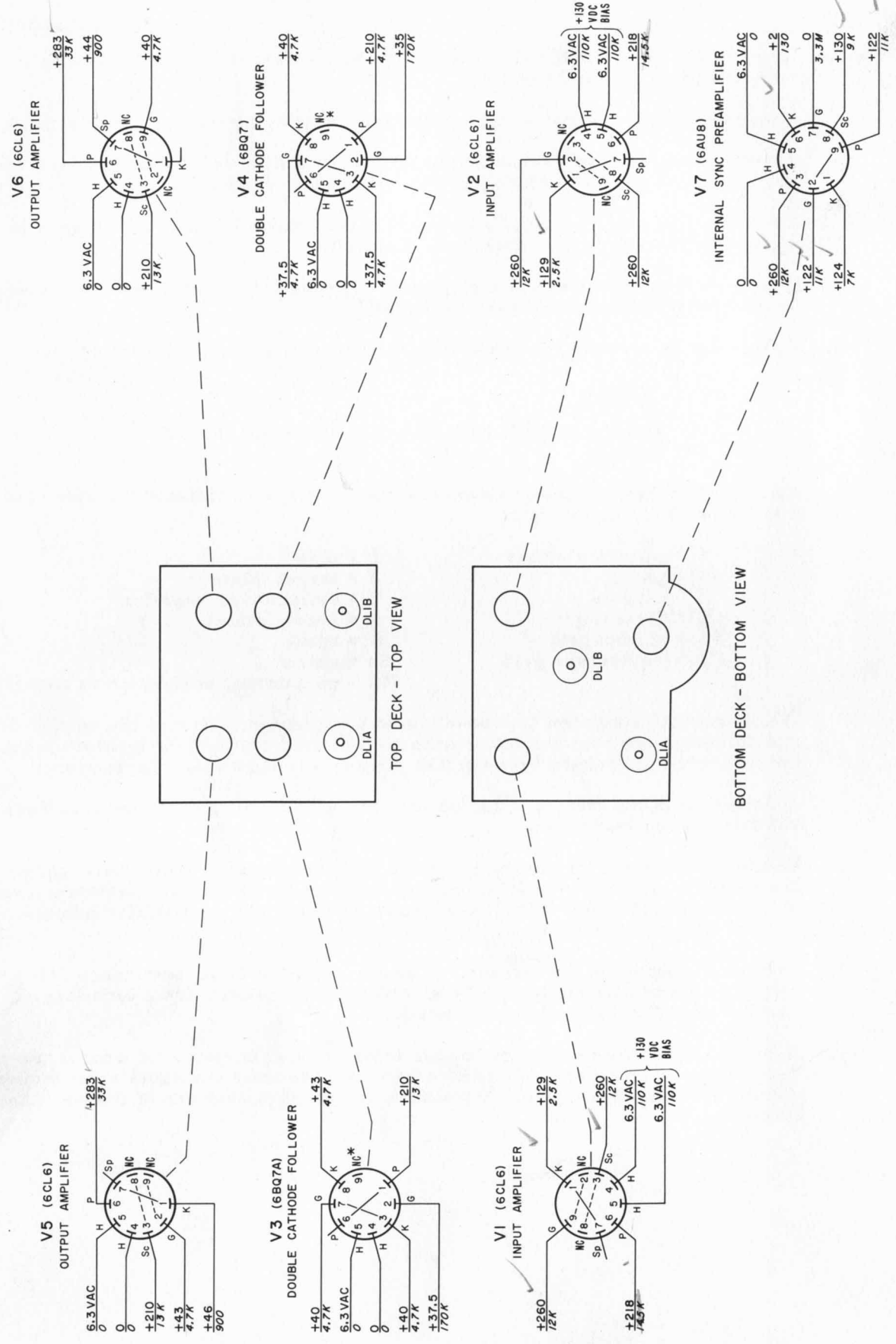

LOWER DECK

UPPER DECK

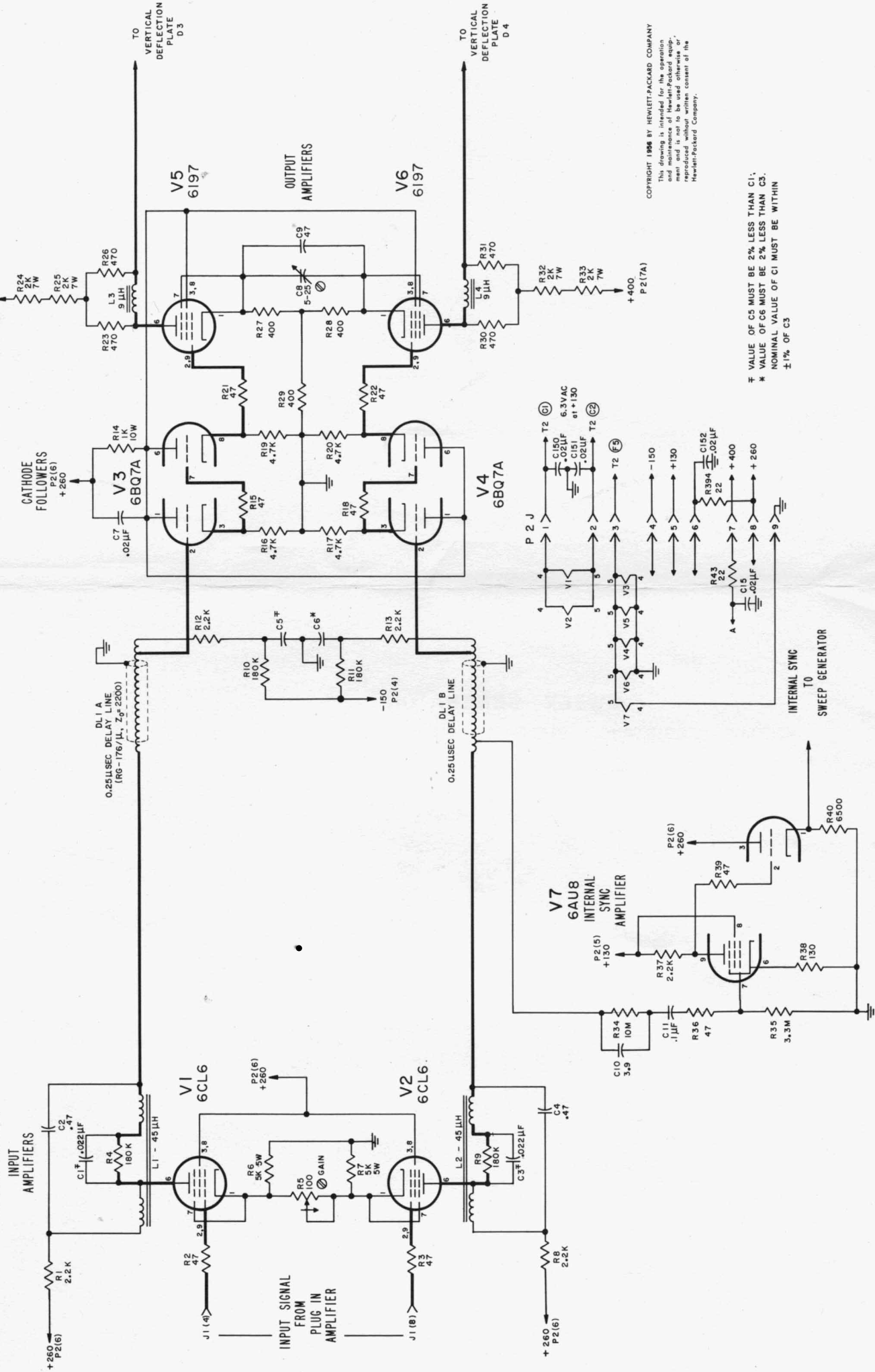

COPYRIGHT 1966 BY HEWLETT-PACKARD COMPANY  
 This drawing is intended for the operation and maintenance of Hewlett-Packard equipment and is not to be used otherwise or reproduced without the written consent of the Hewlett-Packard Company.

† VALUE OF C5 MUST BE 2% LESS THAN C1;  
 \* VALUE OF C6 MUST BE 2% LESS THAN C5.  
 ‡ NOMINAL VALUE OF C1 MUST BE WITHIN ±1% OF C3

**hp MODEL 150A**  
**MAIN VERTICAL AMPLIFIER**  
 SERIAL 1148 & ABOVE



# SWEEP GENERATOR

## VOLTAGE - RESISTANCE DIAGRAM (VIEWED FROM OUTSIDE)

NOTE: WHEN THREE VOLTAGES ARE SHOWN, THE FIRST TWO ARE THE BEGINNING AND ENDING OF A SWEEP WITH THE SWEEP MODE CONTROL SET WHERE FREE RUNNING FIRST OCCURS. THE LAST VOLTAGE IS OBTAINED WITH THE SWEEP MODE CONTROL SET TO MAX. CCW POSITION BEFORE PRESET, GENERATOR NOT SWEEPING.

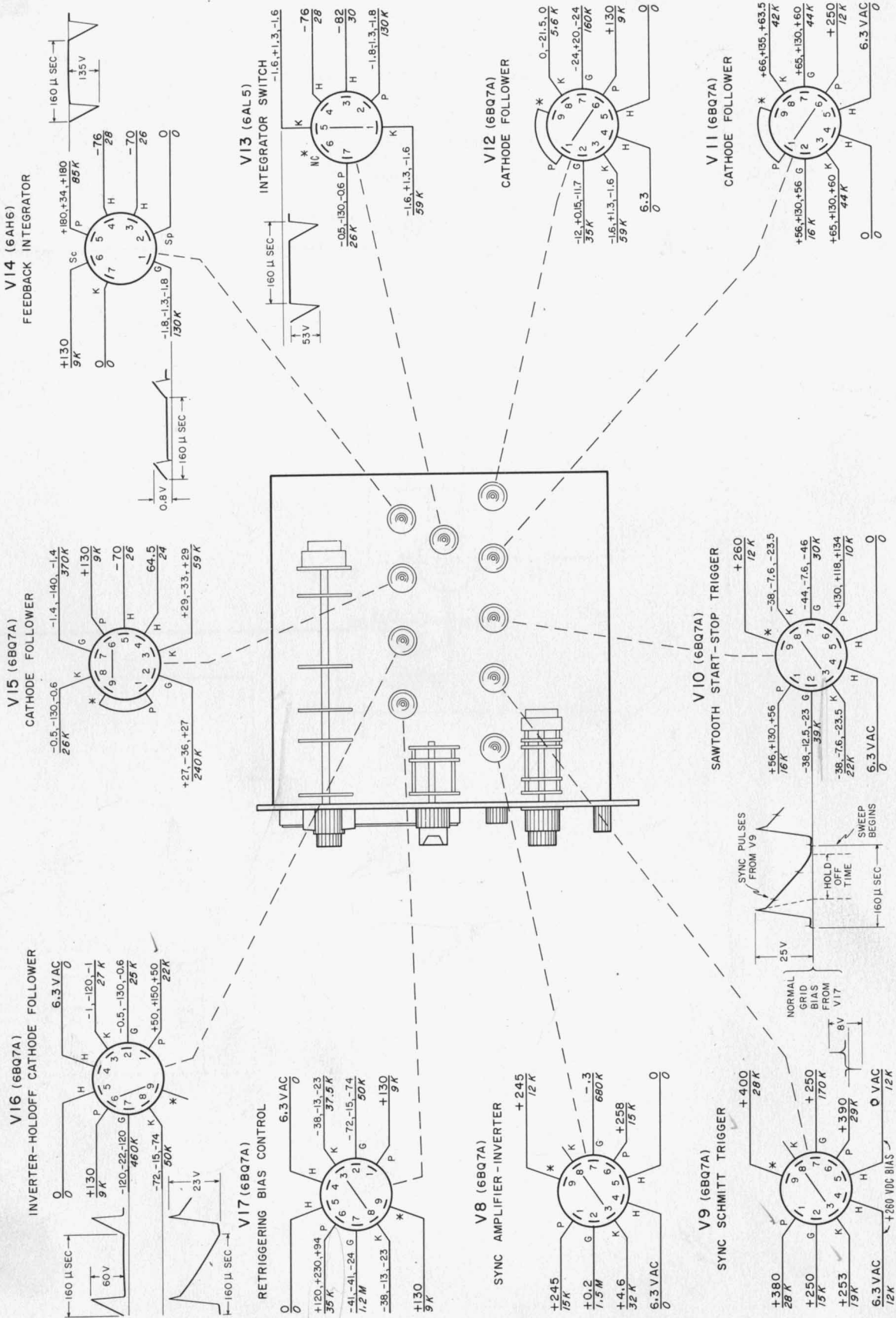

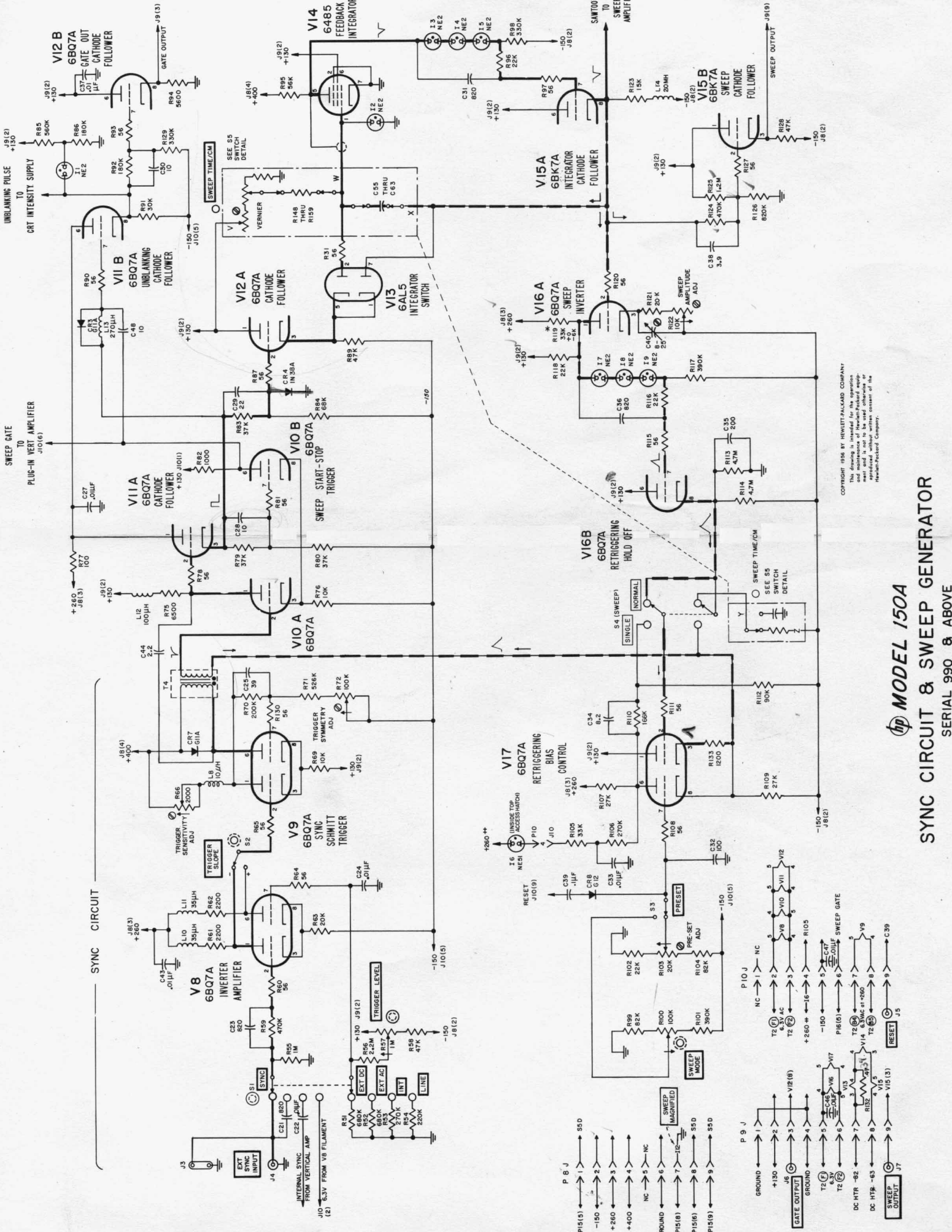

COPYRIGHT 1956 BY HEWLETT-PACKARD COMPANY  
 This drawing is unclassified but its operation may be disclosed in whole or in part without the consent of the Hewlett-Packard Company.

**MODEL 150A**  
**SYNC CIRCUIT & SWEEP GENERATOR**  
 SERIAL 990 & ABOVE

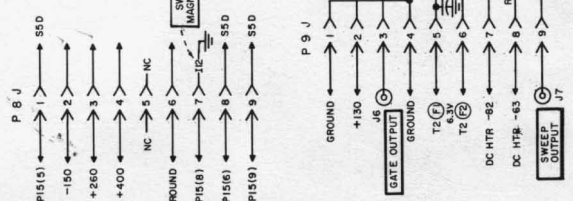

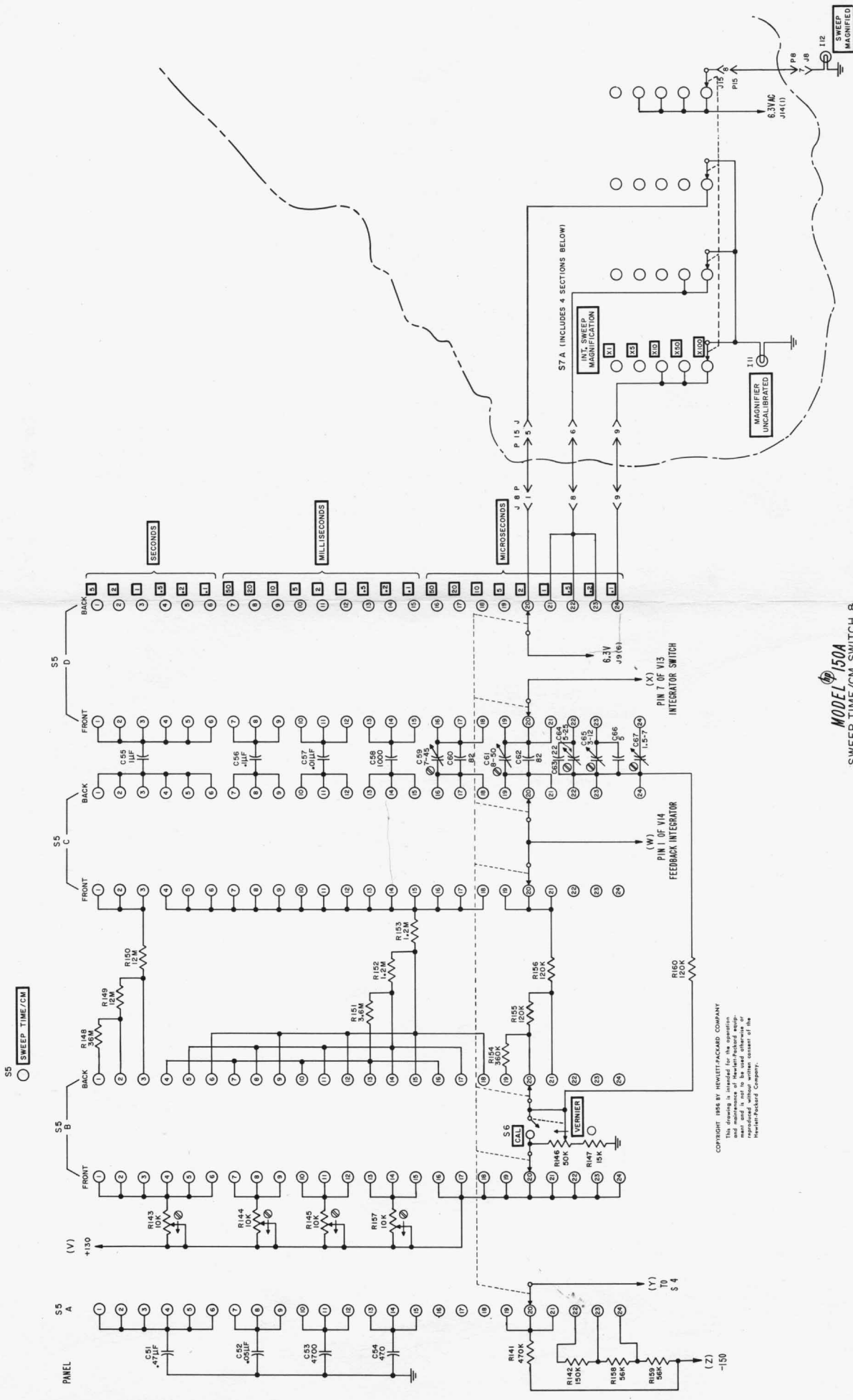

MODEL 150A  
SWEEP TIME/CM SWITCH &  
MAGNIFIER LIGHTS  
Serial 1121 & Above

COPYRIGHT 1966 BY HEWLETT-PACKARD COMPANY  
This drawing is intended for the operation of the Model 150A Sweep Time/CM Switch & Magnifier Lights. It is not to be used otherwise or modified without the written consent of the Hewlett-Packard Company.

# HORIZONTAL AMPLIFIER VOLTAGE - RESISTANCE DIAGRAM (VIEWED FROM OUTSIDE)

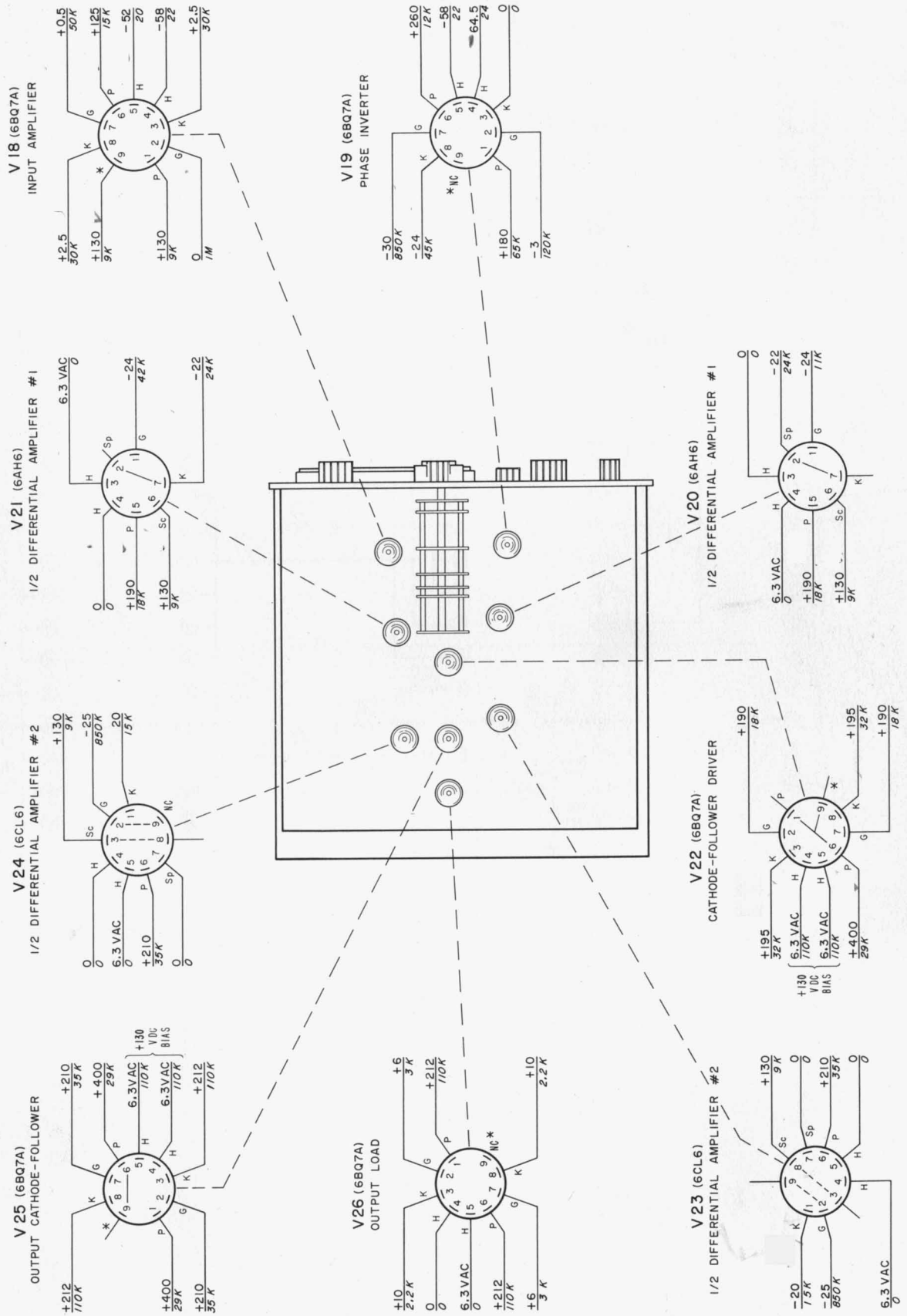

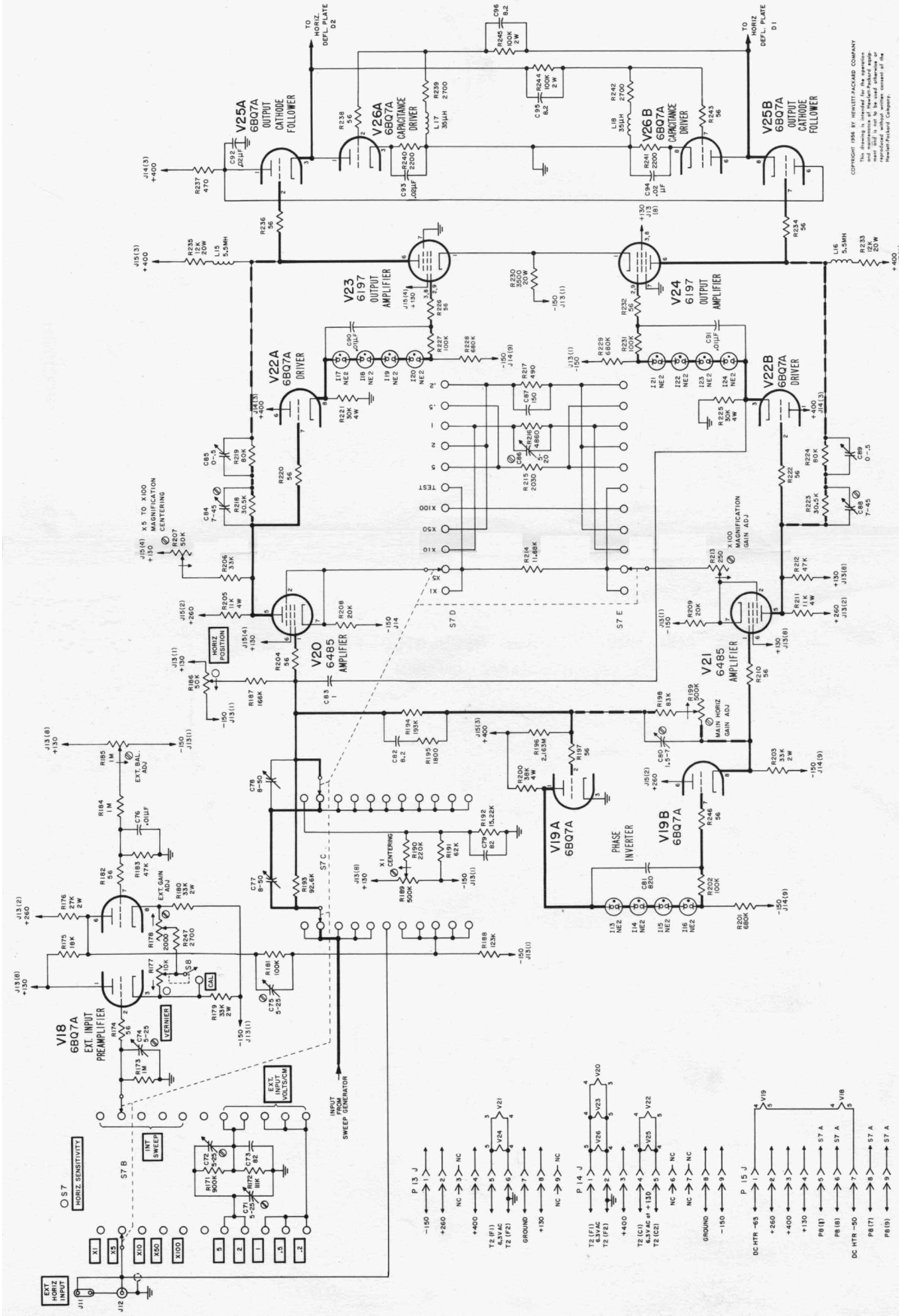

Copyright 1956 by Hewlett-Packard Company  
 This drawing is intended for the operation of the Model 150A and is not to be used otherwise or modified without the written consent of the Hewlett-Packard Company.

**hp MODEL 150A**  
**HORIZONTAL AMPLIFIER**  
 SERIAL 240 & ABOVE

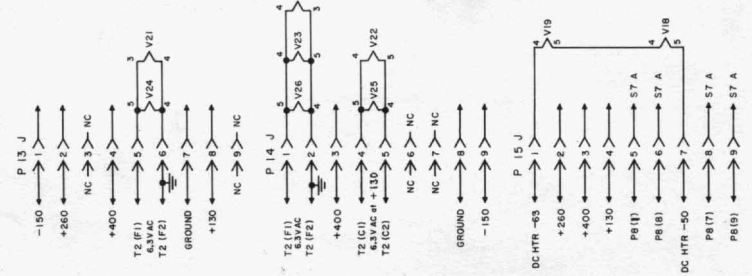

# CALIBRATOR AND HIGH VOLTAGE REGULATED POWER SUPPLY VOLTAGE - RESISTANCE DIAGRAM

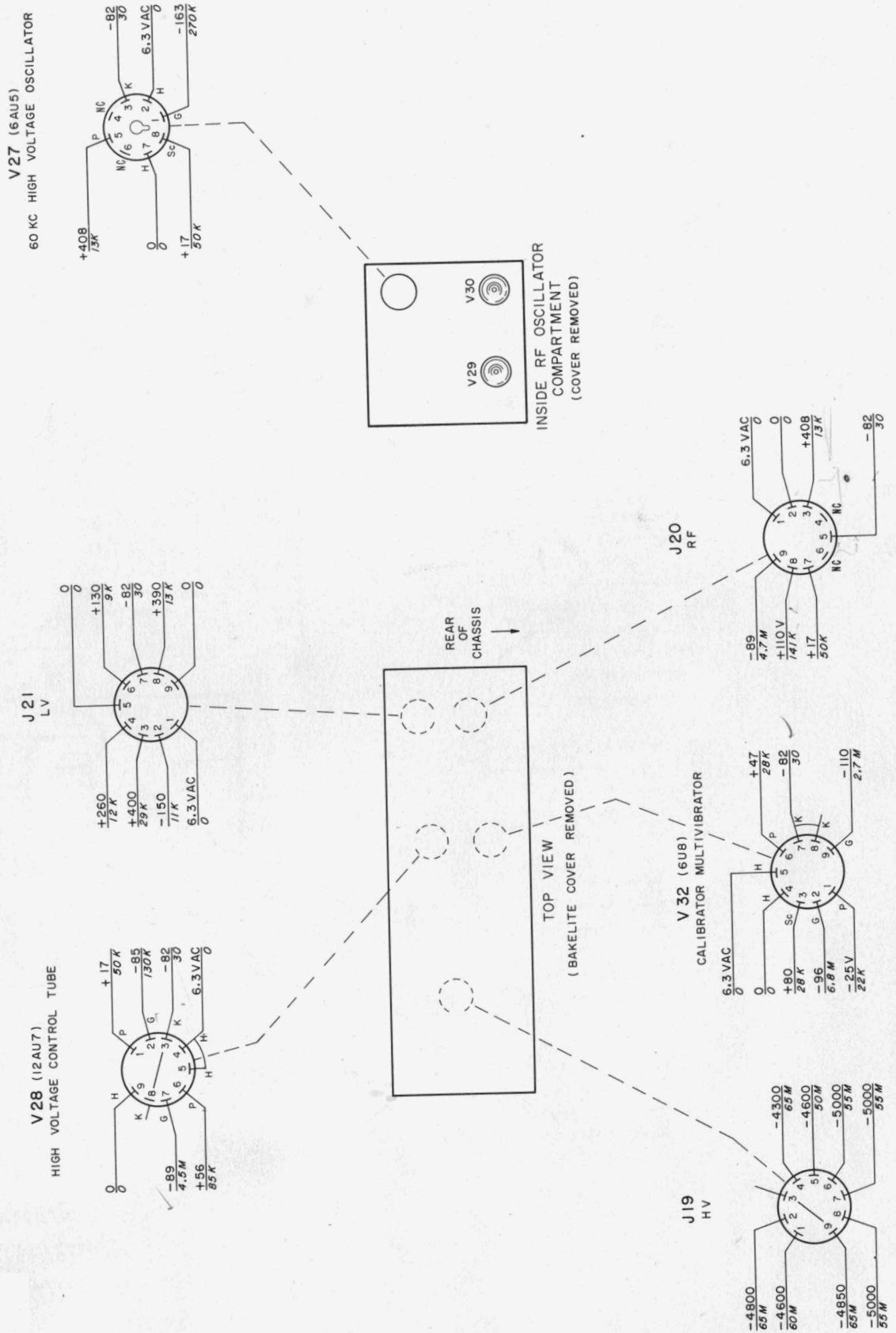



# LOW VOLTAGE POWER SUPPLY VOLTAGE - RESISTANCE DIAGRAM (VIEWED FROM OUTSIDE)

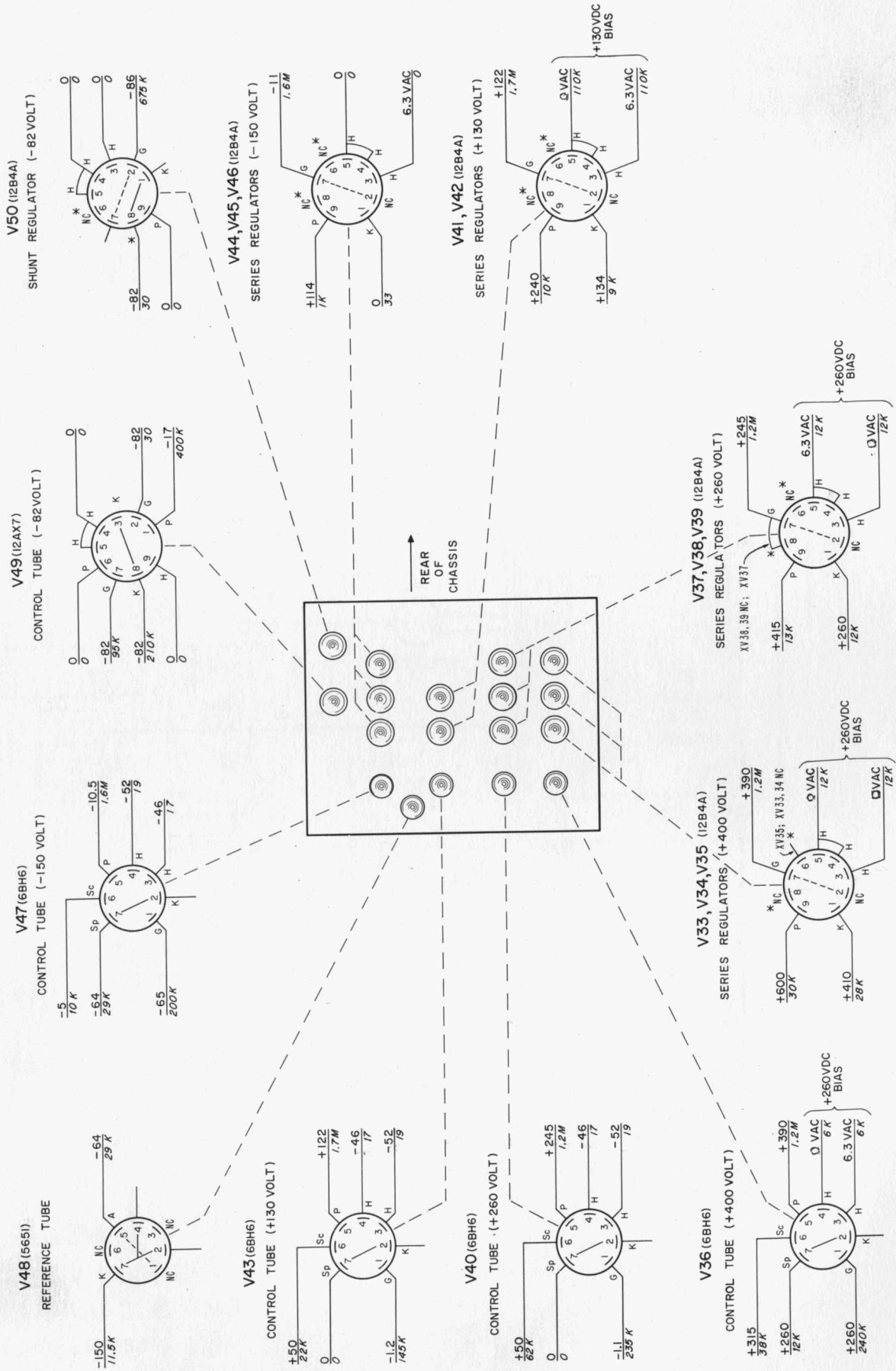



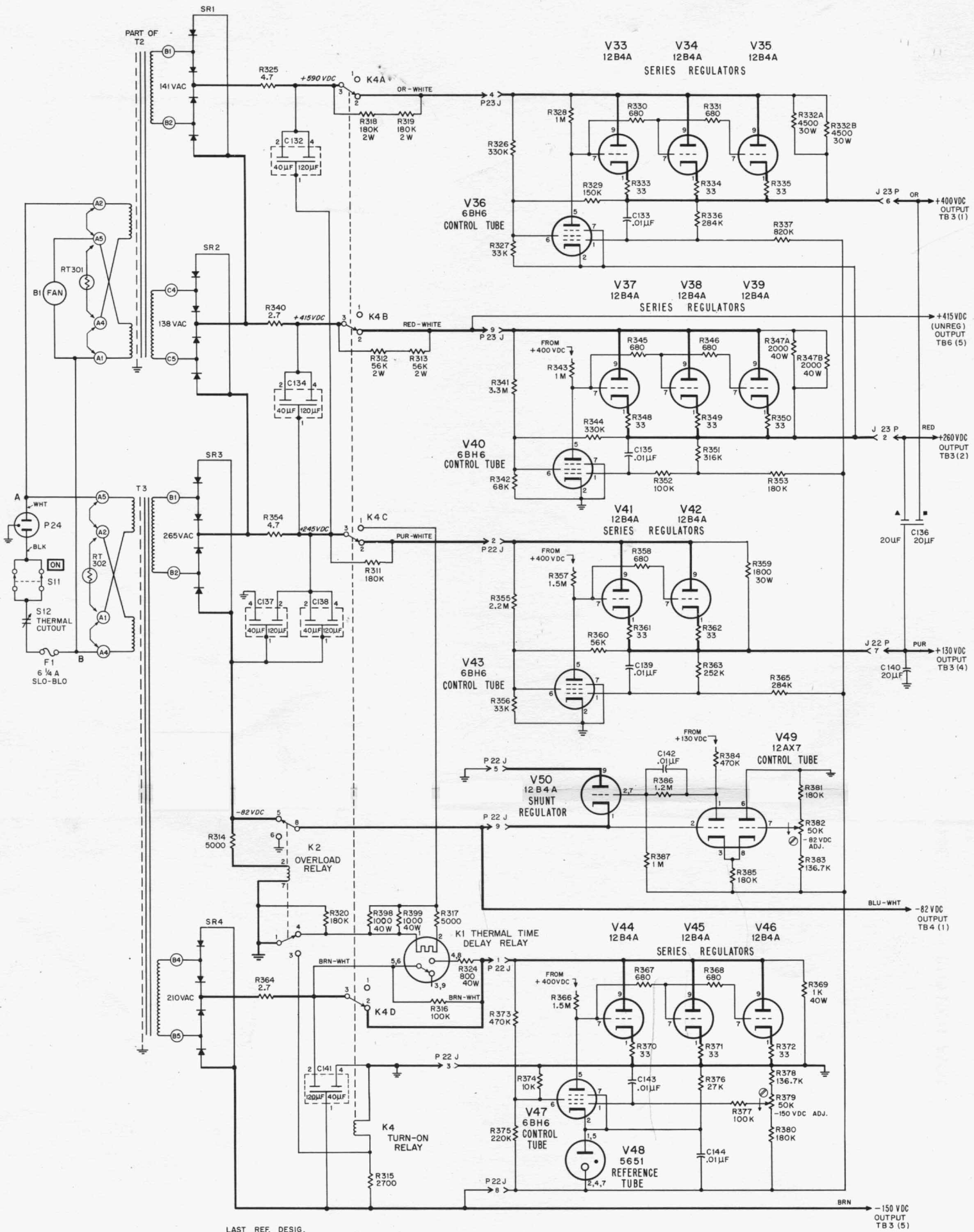

LAST REF. DESIG.

- B — 1
- C — 144
- F — 1
- J — 22
- K — 4
- P — 24
- R — 399
- RT — 302
- S — 12
- T — 3
- V — 48

**MODEL 150 A**  
 LOW VOLTAGE POWER SUPPLY  
 SERIAL 1190 & ABOVE

COPYRIGHT 1956 BY HEWLETT-PACKARD COMPANY  
 This drawing is intended for the operation and maintenance of Hewlett-Packard equipment and is not to be used otherwise or reproduced without written consent of the Hewlett-Packard Company.

# COMPLETE AC HEATER DETAIL

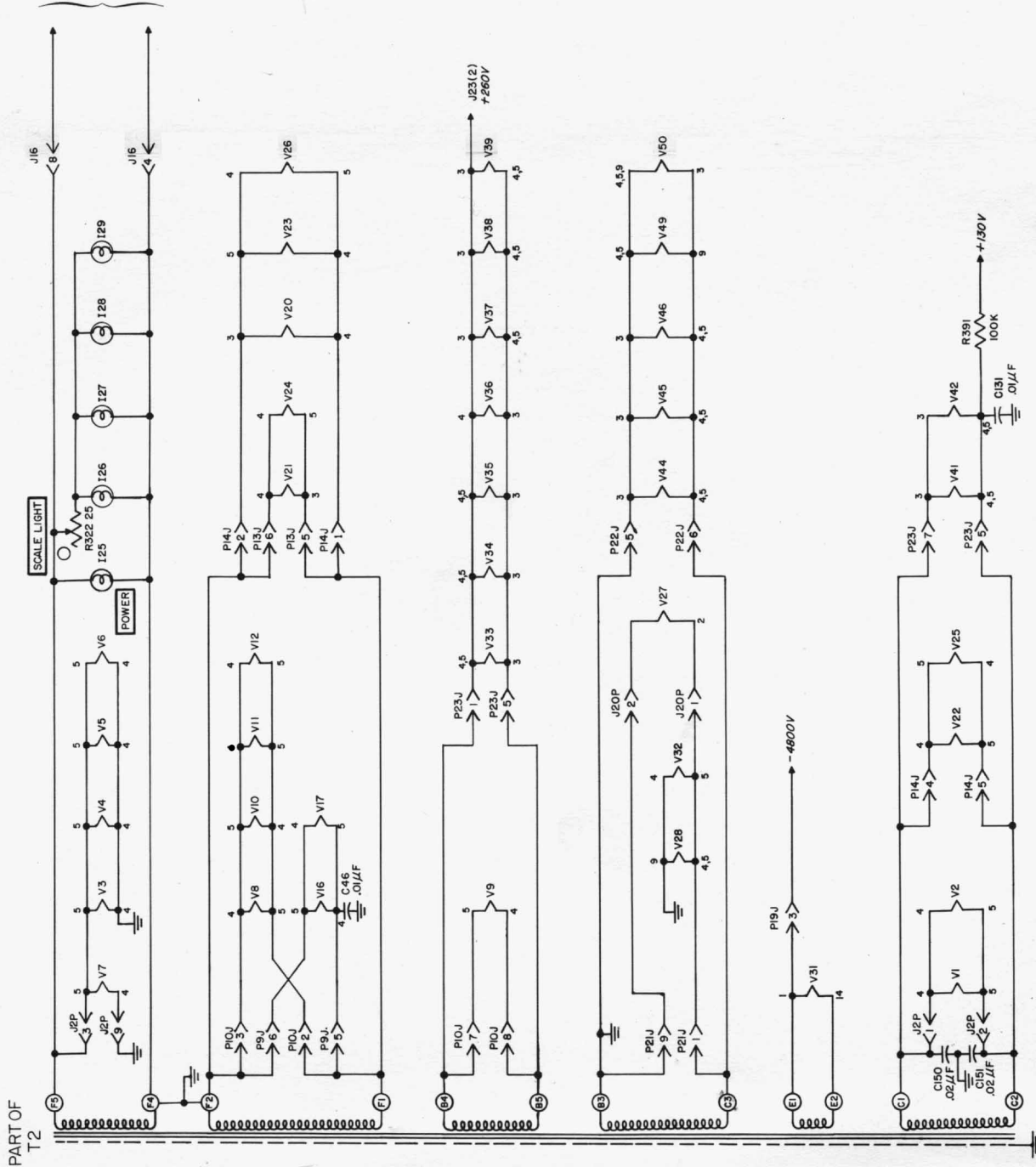

TO PLUG-IN VERTICAL AMPLIFIER

# COMPLETE REGULATED DC HEATER DETAIL

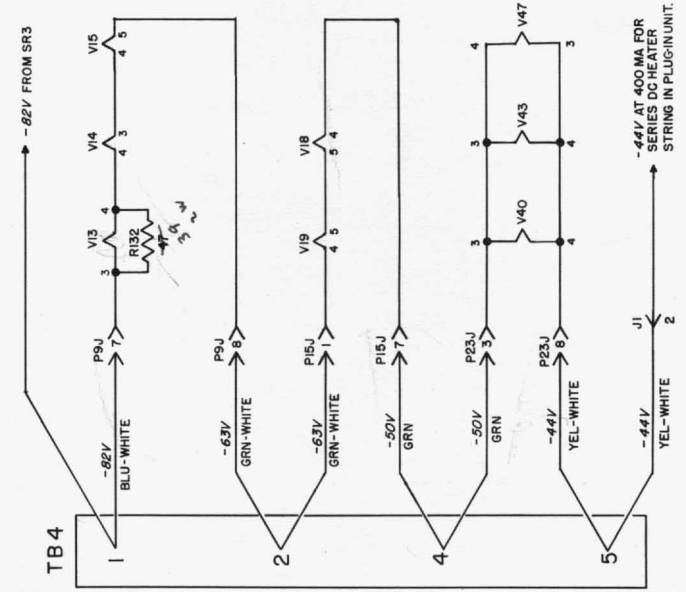

COPYRIGHT 1955 BY HEWLETT-PACKARD COMPANY  
 This drawing is intended for the operation of the Model 150A and is not to be used otherwise or reproduced without written consent of the Hewlett-Packard Company.

# MODEL 150A COMPLETE HEATER DETAIL

SERIAL 340 & ABOVE

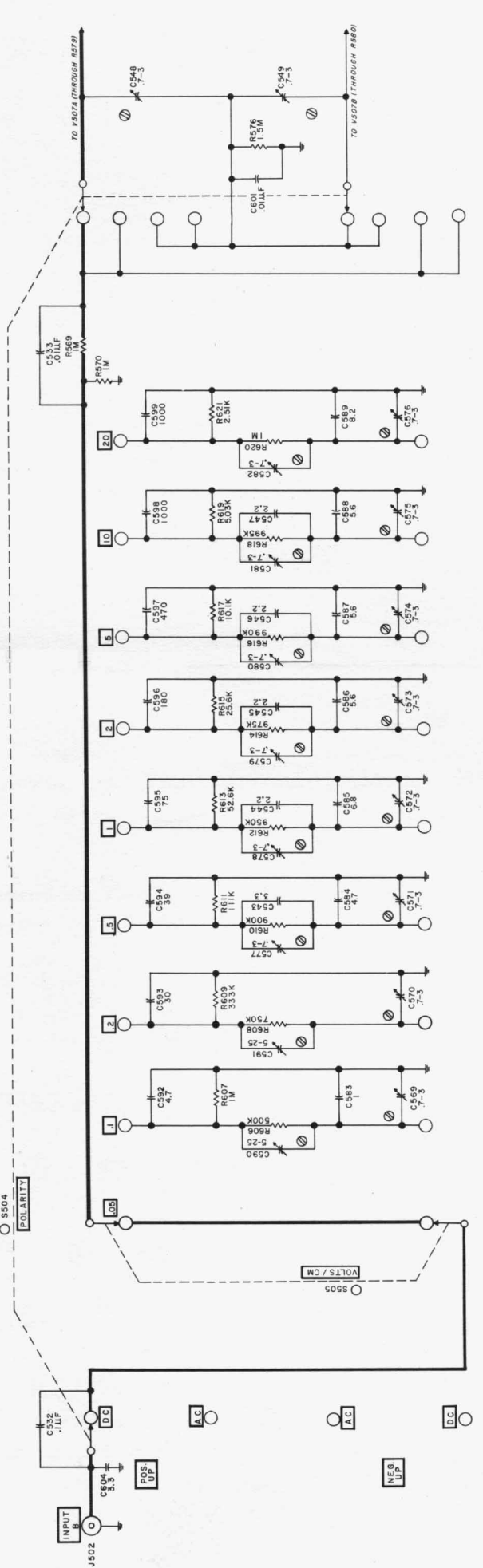
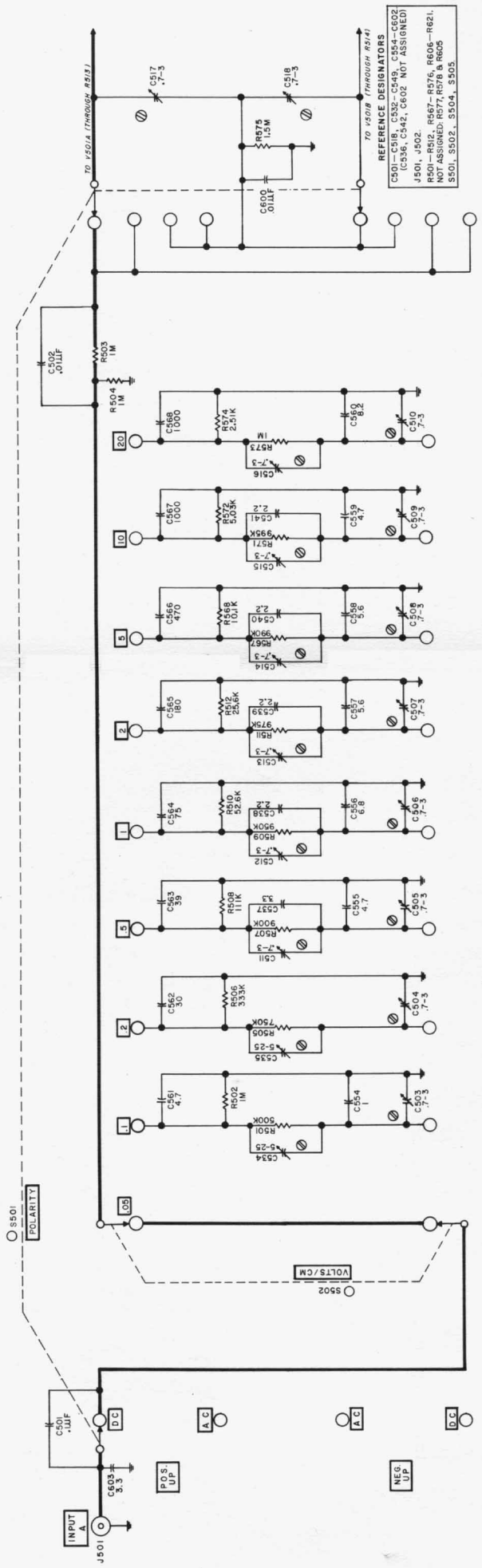

**hp MODEL 152A**  
**VOLTS/CM & POLARITY SWITCHES**  
 SERIAL 1086 & ABOVE

# 152A DUAL CHANNEL, VERTICAL AMPLIFIER, PLUG-IN UNIT

VOLTAGE - RESISTANCE DIAGRAM (VIEWED FROM BOTTOM)

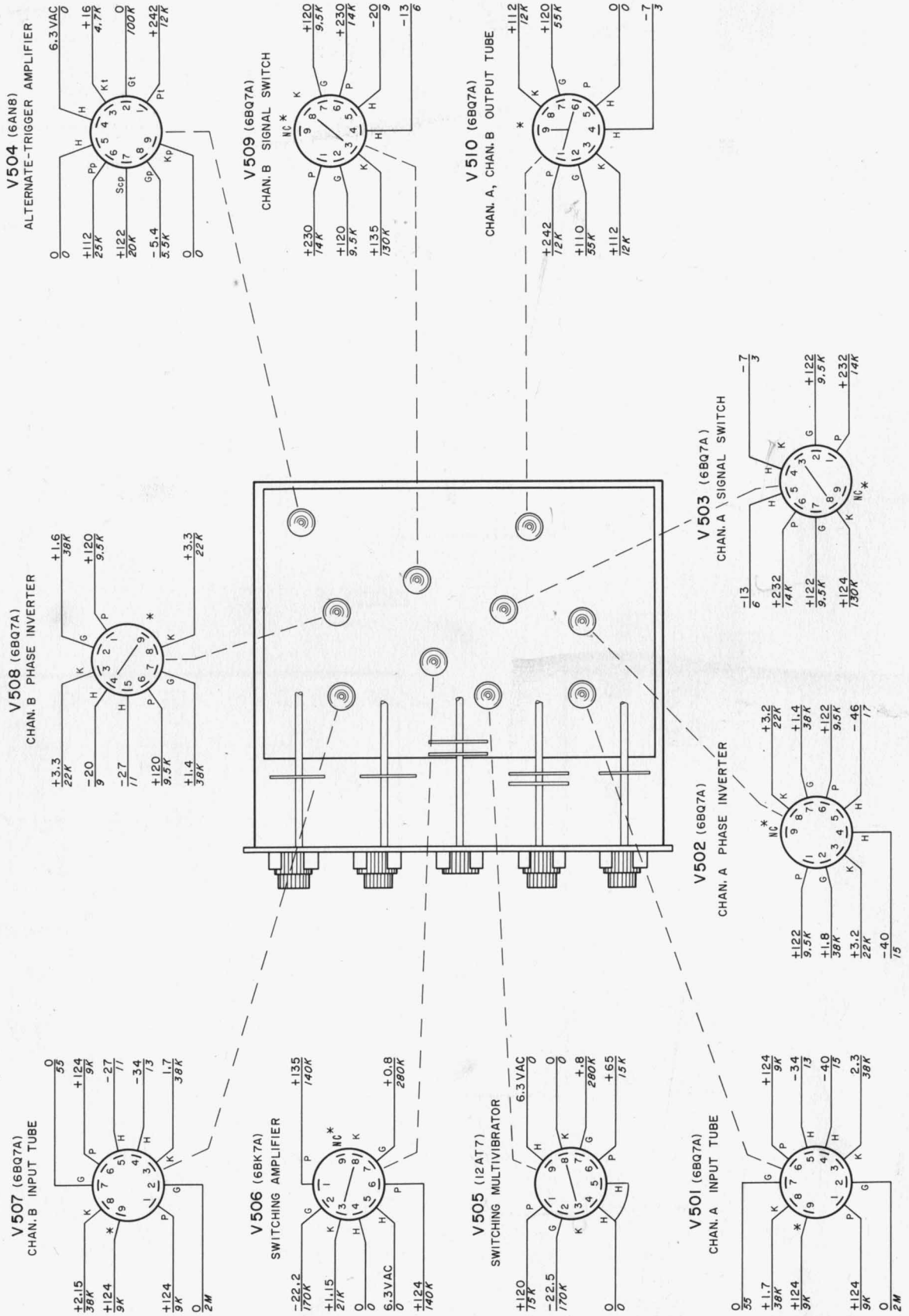

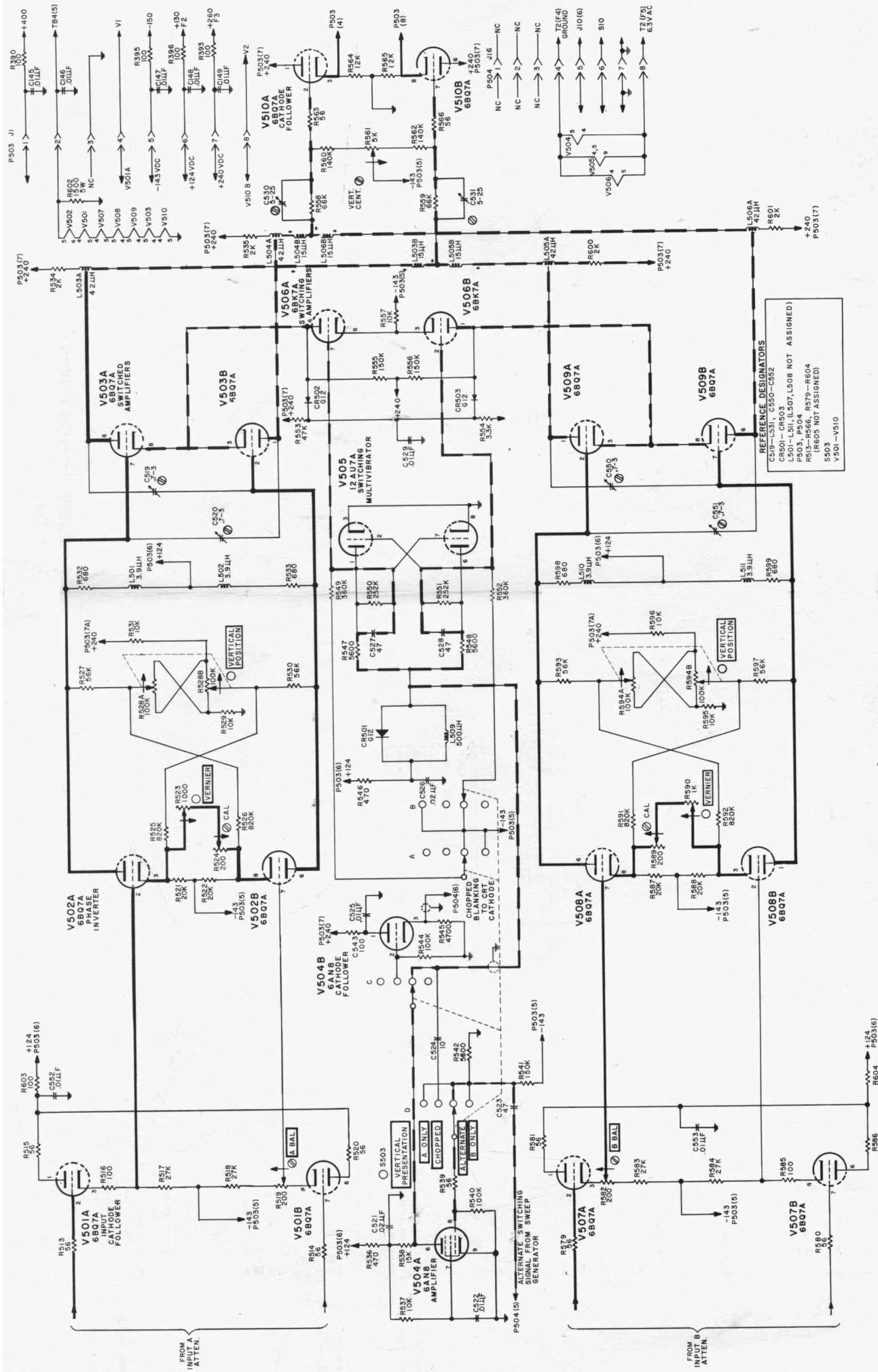

**hp MODEL 152A**  
**DUAL CHANNEL AMPLIFIER**  
 SERIAL I086 & ABOVE

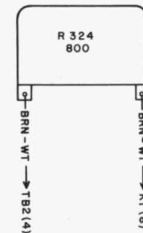
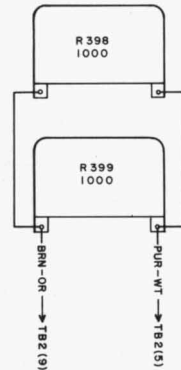
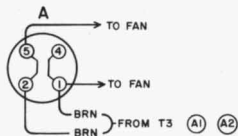
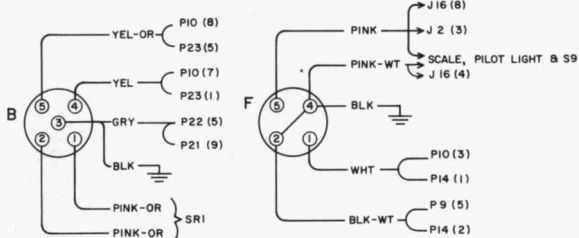
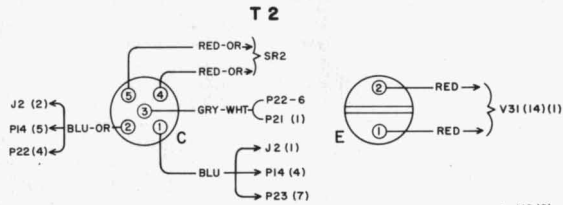
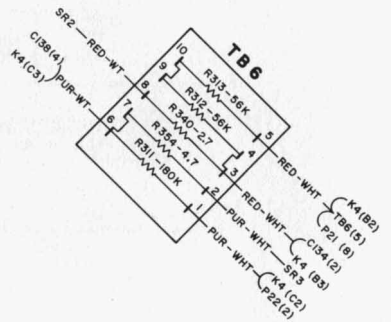
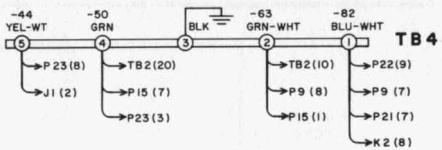
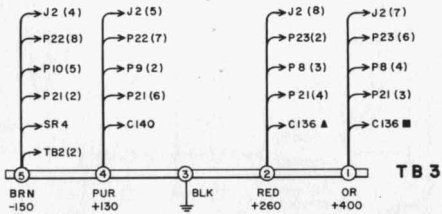
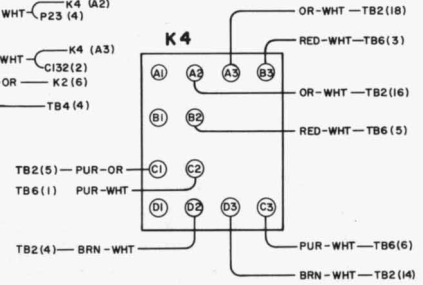
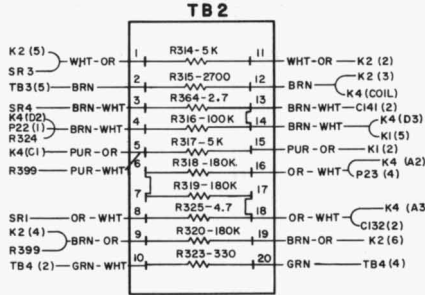
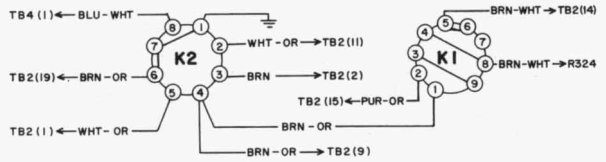
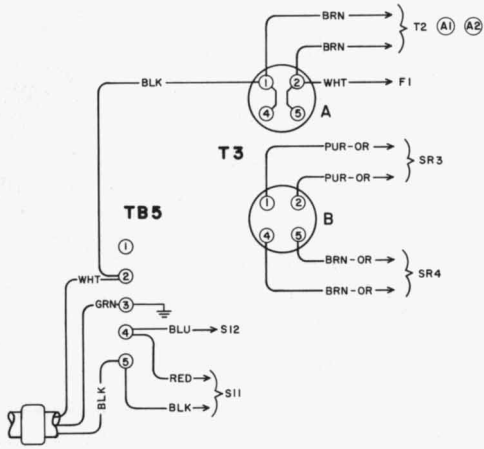

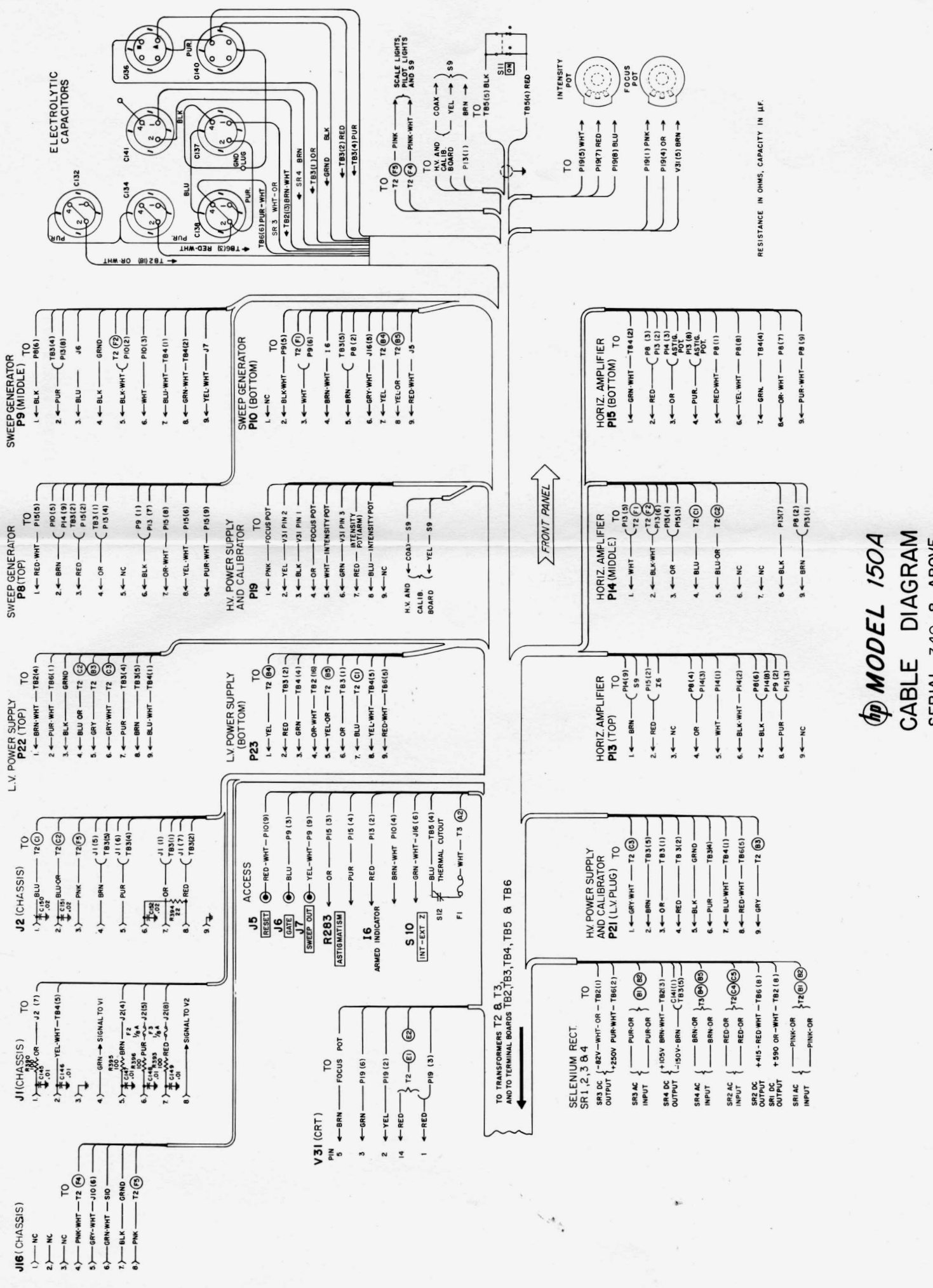

RESISTANCE IN OHMS, CAPACITY IN  $\mu$ F.

**hp MODEL 150A**  
**CABLE DIAGRAM**  
 SERIAL 340 & ABOVE

# SWEEP TIME / CM SWITCH S5

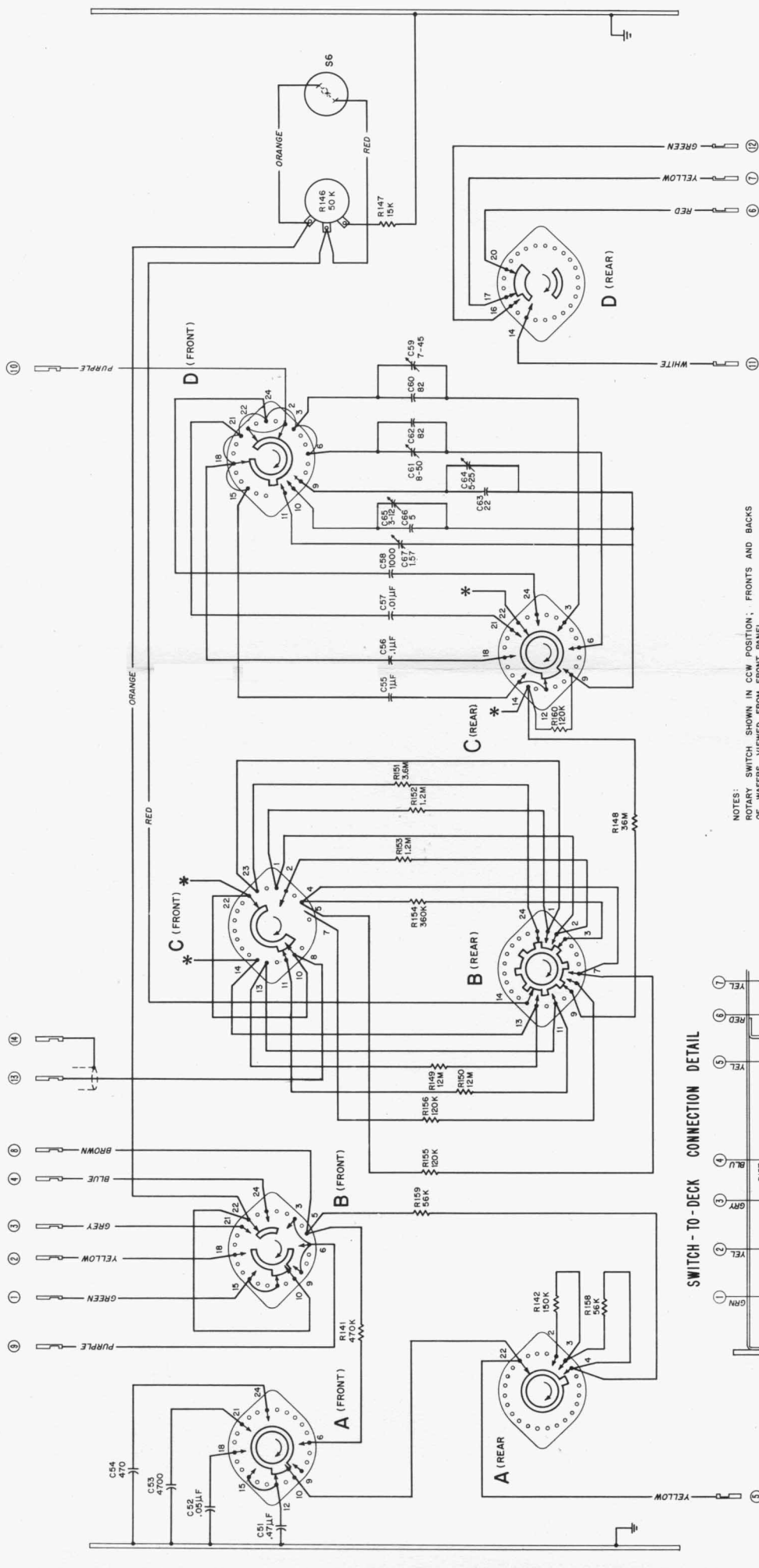

NOTES:  
 ROTARY SWITCH SHOWN IN CCW POSITION; FRONTS AND BACKS OF WAFERS VIEWED FROM FRONT PANEL.  
 \* INDICATES A CONNECTION DIRECTLY THROUGH THE WAFER, CONNECTING CORRESPONDING POINTS TOGETHER.  
 ● MALCO CONNECTOR ON BOARD.

## SWITCH - TO - DECK CONNECTION DETAIL

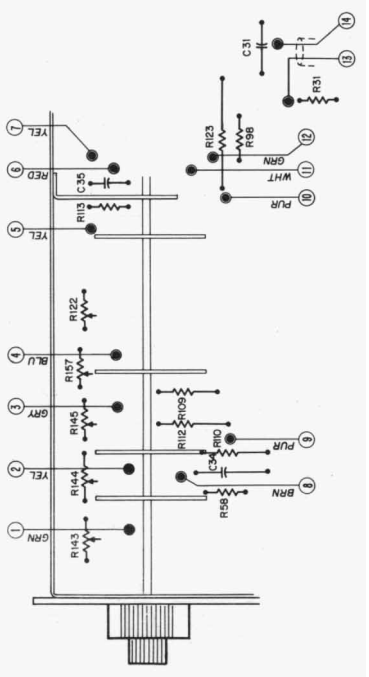

## ← FRONT PANEL



# SYNC SELECTOR SWITCH S1

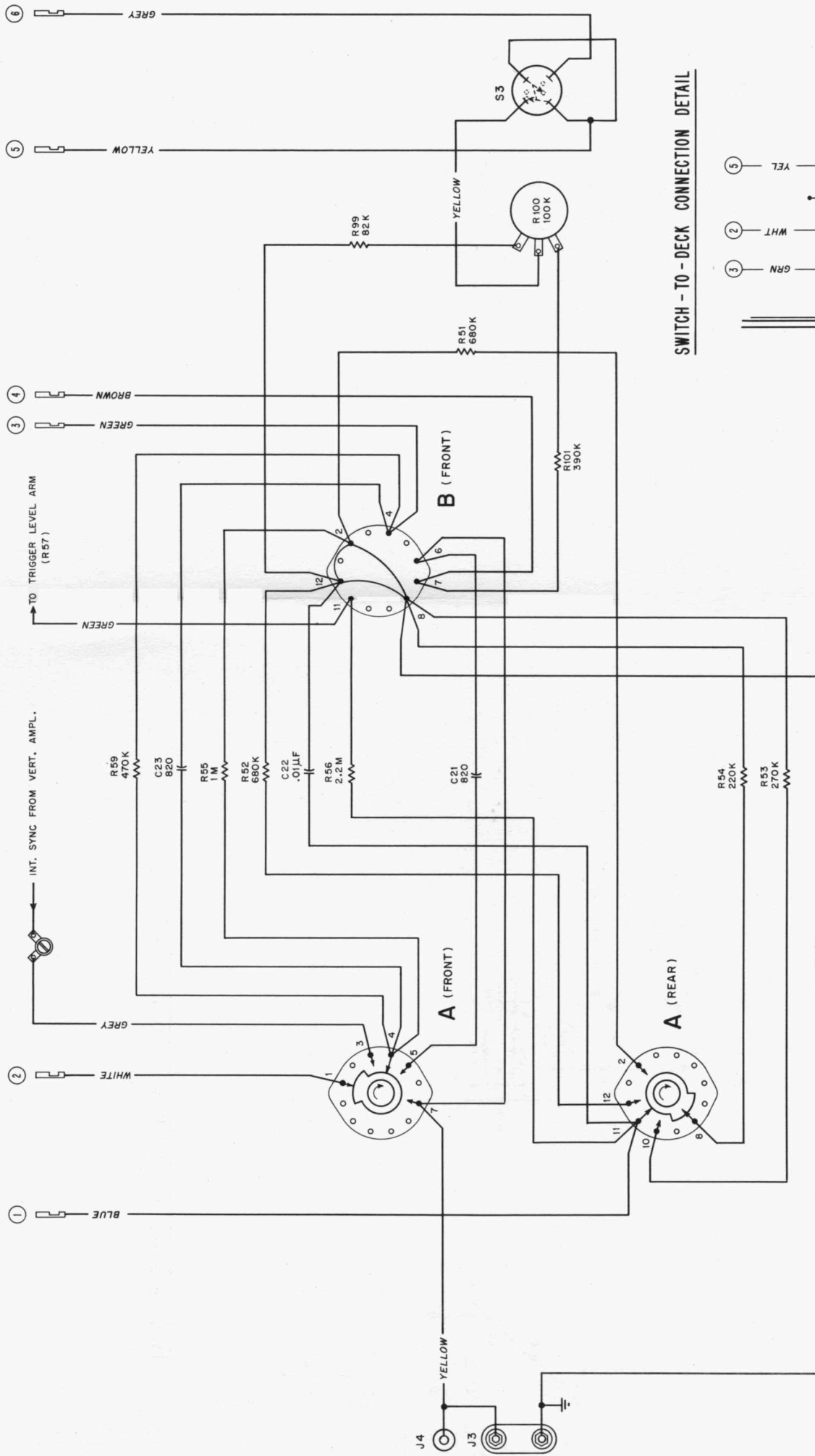

## SWITCH - TO - DECK CONNECTION DETAIL

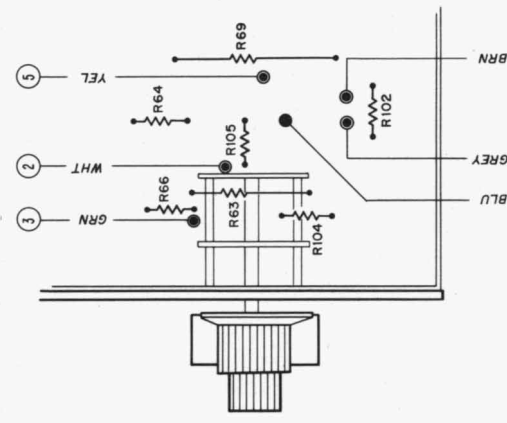

NOTES:  
 ROTARY SWITCH SHOWN IN CCW POSITION; FRONTS AND BACKS  
 OF WAFERS VIEWED FROM FRONT PANEL.  
 ● MALCO CONNECTOR

← FRONT PANEL

HORIZ. SENSITIVITY SWITCH-TO-DECK CONNECTION DETAIL

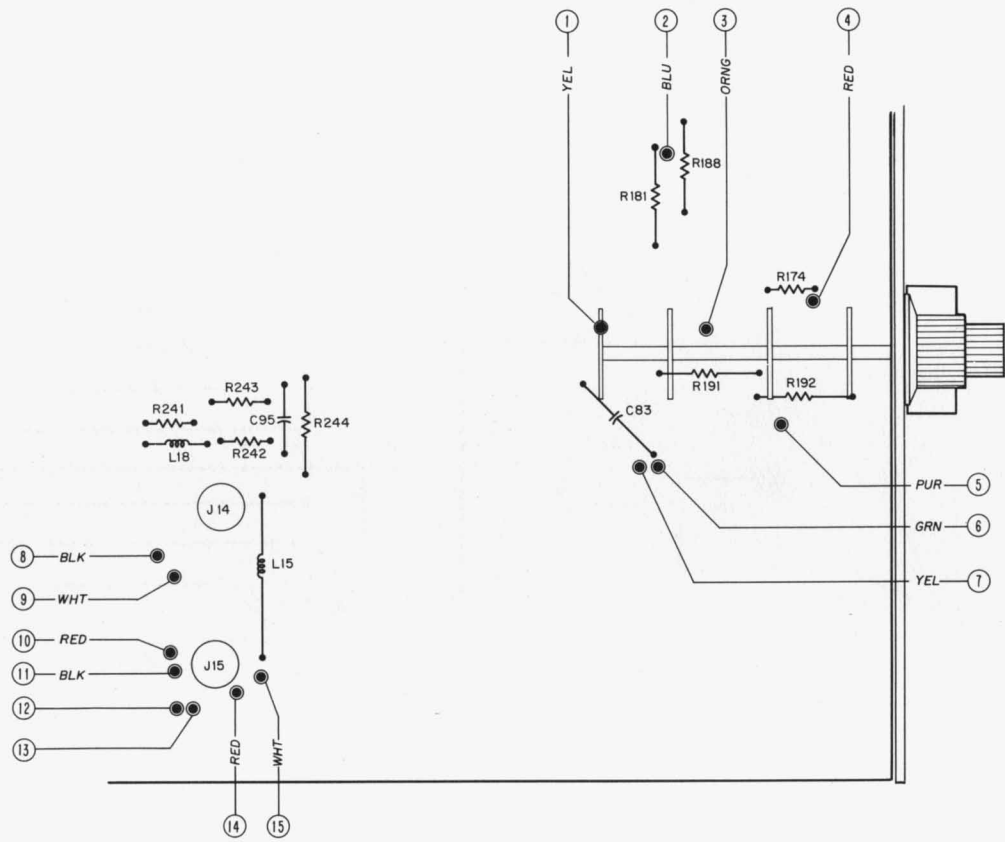

# HORIZ. SENSITIVITY SWITCH S7

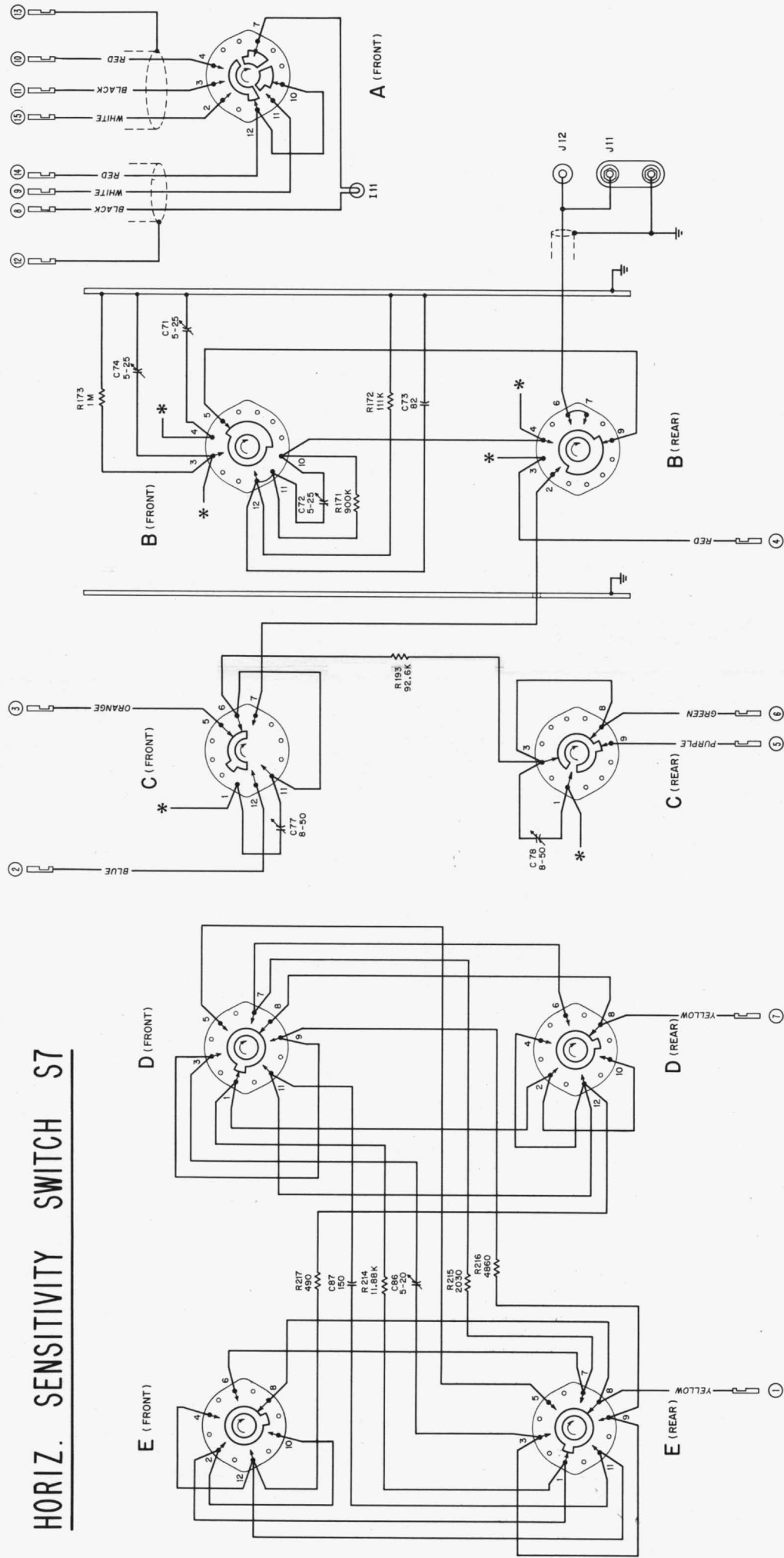

NOTES:  
 ROTARY SWITCH SHOWN IN CCW POSITION; FRONTS AND BACKS OF WAFERS VIEWED FROM FRONT PANEL.  
 \* INDICATES A CONNECTION DIRECTLY THROUGH THE WAFER, CONNECTING CORRESPONDING POINTS TOGETHER.

FRONT PANEL →

# CALIBRATOR SWITCH S9

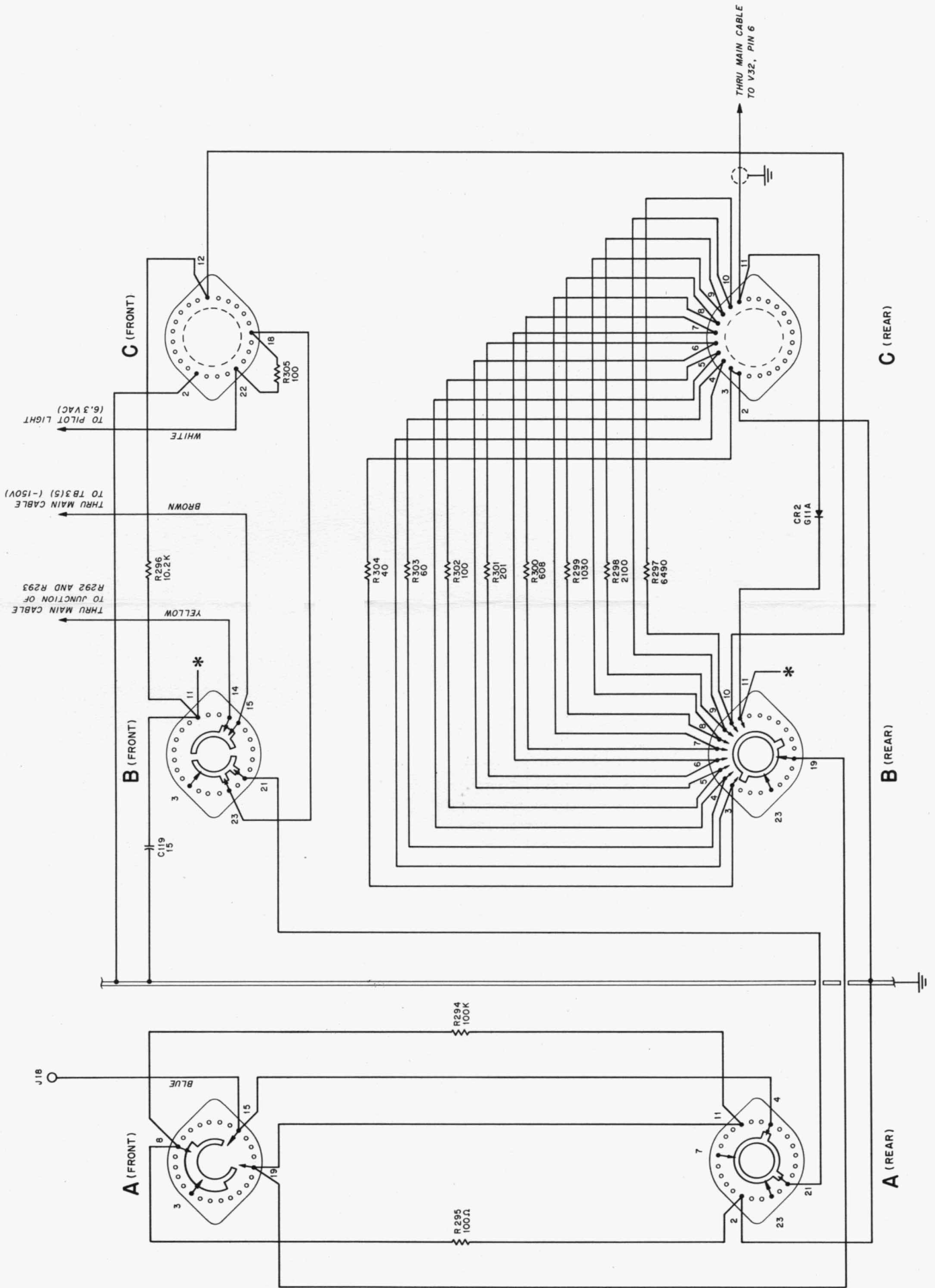

ROTARY SWITCH SHOWN IN CCW POSITION; FRONTS AND BACKS OF WAFERS VIEWED FROM FRONT PANEL  
 \* INDICATES A CONNECTION DIRECTLY THROUGH THE WAFER, CONNECTING CORRESPONDING POINTS TOGETHER.

← FRONT PANEL

**SECTION V**  
**TABLE OF REPLACEABLE PARTS**

**NOTE**

Any changes in the Table of Replaceable Parts will be listed on a Production Change sheet at the front of this manual.

When ordering parts from the factory always include the following information:

Instrument model number  
Serial number  
-hp- stock number of part  
Description of part

**TABLE OF REPLACEABLE PARTS**

Circuit Ref.	Description	Stock No.	Mfr. * & Mfrs. Designation
<u>MAIN VERTICAL AMPLIFIER</u>			
C1	Capacitor: selected values; replace in sets	150A-95D	HP
C2	Capacitor: fixed, titanium dioxide dielectric, .47 $\mu$ f, $\pm$ 5%, 500 vdcw	15-74	DD Type GA
C3	Capacitor: selected values; replace in sets	150A-95D	HP
C4	Capacitor: fixed, titanium dioxide dielectric, .47 $\mu$ f, $\pm$ 5%, 500 vdcw	15-74	DD Type GA
C5, C6	Capacitors: selected values; replace in sets	150A-95D	HP
C7	Capacitor: fixed, ceramic disc, .02 $\mu$ f, tol. +100% -0%, 600 vdcw	15-85	R. M. C. Type B
C8	Capacitor: variable, ceramic, trimmer, 5-25 $\mu$ f	13-28	L Style 557-23
C9	Capacitor: fixed, mica, 47 $\mu$ f, $\pm$ 5%, 300 vdcw	14-74	V, Type PQ
C10	Capacitor: fixed, titanium dioxide dielectric, 3.9 $\mu$ f, $\pm$ 10%, 500 vdcw	15-126	DD Type GA
C11	Capacitor: fixed, mylar dielectric, .1 $\mu$ f, $\pm$ 5%, 200 vdcw	16-103	Goodall 620M10452
C12, C13, C14	These circuit references not assigned	-----	-----
DL 1A, DL 1B	Delay Line Cable Pair: 2200 ohms	150A-16J	HP
L1, L2	Bridged "T" Coil Assembly: 2400 ohms	150A-60C	HP
L3, L4	Coil, R. F., 9 $\mu$ h	150A-60D	HP
P2	Plug, male, noval	150A-95F	HP
R1A	Resistor: fixed, metal film on glass body, 2.2K ohms, $\pm$ 1%, 4 W	334-2.2K	AB Type S30
R2, R3	Resistor: fixed, composition, 47 ohms, $\pm$ 10%, 1/2 W	23-47	B EB 4701
R4	Resistor: fixed, deposited carbon, 180,000 ohms, $\pm$ 1%, 1/2 W	33-180K	NN DC-1/2C
R5	Resistor: variable, 100 ohms, $\pm$ 20%, .2W	210-166	BO, Type 70
R6, R7	Resistor: fixed, metal film on glass body, 5000 ohms, $\pm$ 5%, 5 W	335-5K-5	AB LP-5
R8A	Resistor: fixed, metal film on glass body, 2.2K ohms, $\pm$ 1%, 4 W	334-2.2K	AB Type S30
R8B			

\* See "List of Manufacturers Code Letters for Replaceable Parts Table".

**TABLE OF REPLACEABLE PARTS**

<b>Circuit Ref.</b>	<b>Description</b>	<b>Stock No.</b>	<b>Mr. * &amp; Mrs. Designation</b>
	<u>MAIN VERTICAL AMPLIFIER (CONT'D.)</u>		
R9, R10, R11	Resistor: fixed, deposited carbon, 180,000 ohms, $\pm 1\%$ , 1/2 W	33-180K	NN DC-1/2C
R12A	Resistor: fixed, carbon film on ceramic body, 2.2K ohms, $\pm 1\%$ , 1/4 W	30-2.2K	NN DC-1/4
R13A	Resistor: fixed, carbon film on ceramic body, 2.2K ohms, $\pm 1\%$ , 1/4 W	30-2.2K	NN DC-1/4
R14	Resistor: fixed, wirewound, 1000 ohms, $\pm 10\%$ , 10W	26-17	I A-10-F
R15	Resistor: fixed, composition, 47 ohms, $\pm 10\%$ , 1/2 W	23-47	B EB 4701
R16, R17	Resistor: fixed, composition, 4700 ohms, $\pm 10\%$ , 1 W	24-4700	B GB 4721
R18	Resistor: fixed, composition, 47 ohms, $\pm 10\%$ , 1/2 W	23-47	B EB 4701
R19, R20	Resistor: fixed, composition, 4700 ohms, $\pm 10\%$ , 1 W	24-4700	B GB 4721
R21, R22	Resistor: fixed, composition, 47 ohms, $\pm 10\%$ , 1/2 W	23-47	B EB 4701
R23	Resistor: fixed, composition, 470 ohms, $\pm 5\%$ , 1/2 W	23-470-5	B EB 4715
R24, R25	Resistor: fixed, metal film on glass body, 2000 ohms, $\pm 5\%$ , 7 W	337-2K-5	AB LP-7
R26	Resistor: fixed, composition, 470 ohms, $\pm 5\%$ , 1/2 W	23-470-5	B EB 4715
R27, R28	Resistor: fixed, metal film on glass body, 400 ohms, $\pm 5\%$ , 3 W	333-400-5	AB LP-3
R29	Resistor: fixed, metal film on glass body, 400 ohms, $\pm 5\%$ , 3 W	333-400-5	AB LP-3
R30, R31	Resistor: fixed, composition, 470 ohms, $\pm 5\%$ , 1/2 W	23-470-5	B EB 4715
R32, R33	Resistor: fixed, metal film on glass body, 2000 ohms, $\pm 5\%$ , 7 W	337-2K-5	AB LP-7
R34	Resistor: fixed, composition, 10 megohms, $\pm 10\%$ , 1/2 W	23-10M	B EB 1061
R35	Resistor: fixed, 3.3 megohms, $\pm 10\%$ , 1/2W	23-3.3M	B, EB 1355

\* See "List of Manufacturers Code Letters for Replaceable Parts Table".

**TABLE OF REPLACEABLE PARTS**

Circuit Ref.	Description	Ⓢ Stock No.	Mfr. * & Mfrs. Designation
R36	Resistor: fixed, composition, 47 ohms, ±10%, 1/2 W	23-47	B EB 4701
R37	Resistor: fixed, composition, 2200 ohms, ±10%, 1 W	24-2200	B GB 2221
R38	Resistor: fixed, composition, 130 ohms, ±5%, 1/2 W	23-130-5	B EB 1315
R39	Resistor: fixed, composition, 47 ohms, ±10%, 1/2 W	23-47	B EB 4701
R40	Resistor: fixed, metal film on glass body, 6500 ohms, ±5%, 3 W	333-6500-5	AB LP-3
R41	This circuit reference not assigned	-----	-----
R43	Resistor: fixed, composition, 22 ohms, ±10%, 1/2 W	23-22	B EB 2201
V1, V2	Tube: 6197 or 6CL6	212-6197 or 212-6CL6	ZZ ZZ
V3, V4	Tube: 6BQ7A	212-6BQ7A	ZZ
V5, V6	Tube: 6197 or 6CL6	212-6197 or 212-6CL6	ZZ ZZ
V7	Tube: 6AU8	212-6AU8	ZZ
XV1, XV2, XV3, XV4, XV5, XV6, XV7	Socket, tube, noval	120-10	H, 44F-16388

\* See "List of Manufacturers Code Letters for Replaceable Parts Table".



**TABLE OF REPLACEABLE PARTS**

Circuit Ref.	Description	Stock No.	Mfr. * & Mrs. Designation
	<u>SWEEP GENERATOR</u>		
C21	Capacitor: fixed, mica, 820 $\mu\mu\text{f}$ , $\pm 10\%$ , 500 vdcw	14-28	V Type OXM
C22	Capacitor: fixed, mylar dielectric, .01 $\mu\text{f}$ , $\pm 5\%$ , 400 vdcw	16-101	Goodall 620M10354
C23	Capacitor: fixed, mica, 820 $\mu\mu\text{f}$ , $\pm 10\%$ , 500 vdcw	14-28	V Type OXM
C24	Capacitor: fixed, ceramic dielectric, .01 $\mu\text{f}$ , tol. +100%, -0%, 1000 vdcw	15-43	K Type BPD .01
C25	Capacitor: fixed, mica, 39 $\mu\mu\text{f}$ , $\pm 5\%$ , 300 vdcw	14-70	V, Type PQ
C26	This circuit reference not assigned	-----	-----
C27	Capacitor: fixed, ceramic dielectric, .01 $\mu\text{f}$ , tol. +100%, -0%, 1000 vdcw	15-43	K Type BPD .01
C28	Capacitor: fixed, ceramic dielectric, 10 $\mu\mu\text{f}$ , $\pm 0.5 \mu\mu\text{f}$ , NPO temp. coeff. 500 vdcw	15-30	K Type CI-1
C29	Capacitor: fixed, mica, 22 $\mu\mu\text{f}$ , $\pm 5\%$ , 300 vdcw	14-69	V, Type RQ
C30	Capacitor: fixed, mica, 10 $\mu\mu\text{f}$ , $\pm 10\%$ , 500 vdcw	14-10	V, Type OXM
C31	Capacitor: fixed, silver mica, 820 $\mu\mu\text{f}$ , $\pm 5\%$ , 500 vdcw	15-104	Z KR-1382
C32	Capacitor: fixed, mica, 100 $\mu\mu\text{f}$ , $\pm 5\%$ , 300 vdcw	14-76	V Type PQ
C33	Capacitor: fixed, ceramic dielectric, .01 $\mu\text{f}$ , tol. +100%, -0%, 1000 vdcw	15-43	K Type BPD .01
C34	Capacitor: fixed, titanium dioxide, 8.2 $\mu\mu\text{f}$ , $\pm 10\%$ , 500 vdcw	15-123	DD Type GA
C35	Capacitor: fixed, silver mica, 200 $\mu\mu\text{f}$ , $\pm 5\%$ , 500 vdcw	15-103	Z DR-1320
C36	Capacitor: fixed, silver mica, 820 $\mu\mu\text{f}$ , $\pm 5\%$ , 500 vdcw	15-104	Z KR-1382
C37	Capacitor: fixed, ceramic dielectric, .01 $\mu\text{f}$ , tol. +100%, -0%, 1000 vdcw	15-43	K Type BPD .01
C38	Capacitor: fixed, titanium dioxide dielectric, 3.9 $\mu\mu\text{f}$ , $\pm 10\%$ , 500 vdcw	15-126	DD Type GA
C39	Capacitor: fixed, paper dielectric, .1 $\mu\text{f}$ , $\pm 10\%$ , 400 vdcw	16-35	CC 109P10494
C40	Capacitor: variable, ceramic, with slotted head shaft, 8-50 $\mu\mu\text{f}$ , N750 temp. coeff.	13-23	L Style 557
C41, C42	These circuit references not assigned	-----	-----

\* See "List of Manufacturers Code Letters for Replaceable Parts Table".

TABLE OF REPLACEABLE PARTS

Circuit Ref.	Description	Stock No.	Mfr. * & Mfrs. Designation
<u>SWEEP GENERATOR (CONT'D.)</u>			
C43	Capacitor: fixed, ceramic dielectric, .01 $\mu$ f, tol. +100%, -0%, 1000 vdcw	15-43	K Type BPD .01
C44	Capacitor: fixed, titanium dioxide, 2.2 $\mu$ f, $\pm$ 10%, 500 vdcw	15-52	DD GA-4
C45	Capacitor: fixed, ceramic disc. .02 $\mu$ f, tol. +100%, -0%, 600 vdcw	15-85	G DD-203
C46, C47	Capacitor: fixed, ceramic dielectric, .01 $\mu$ f, tol. +100%, -0%, 1000 vdcw	15-43	K Type BPD .01
C48	Capacitor: fixed, ceramic dielectric, 10 $\mu$ $\mu$ f, $\pm$ 0.5 $\mu$ $\mu$ f, NPO temp. coeff., 500 vdcw	15-30	K Type CI-1
C49, C50	These circuit references not assigned.	-----	-----
C51	Capacitor: fixed, paper dielectric, .47 $\mu$ f, $\pm$ 10%, 200 vdcw	16-37	CC 109P47492A
C52	Capacitor: fixed, paper dielectric, .051 $\mu$ f, $\pm$ 10%, 200 vdcw	16-84	Z Type 33
C53	Capacitor: fixed, mica, 4700 $\mu$ $\mu$ f, $\pm$ 10%, 500 vdcw	14-44	Z, C-1247
C54	Capacitor: fixed, mica, 4700 $\mu$ $\mu$ f, $\pm$ 10%, 500 vdcw	14-62	V, Type "O" CM20B471K
C55	Capacitor: fixed, mylar dielectric, 1 $\mu$ f, $\pm$ 5%, 200 vdcw	16-102	Goodall 621M10552
C56	Capacitor: fixed, mylar dielectric, .1 $\mu$ f, $\pm$ 5%, 200 vdcw	16-103	Goodall 620M10452
C57	Capacitor: fixed, mylar dielectric, 0.01 $\mu$ f, $\pm$ 5%, 400 vdcw	16-101	Goodall 620M10354
C58	Capacitor: fixed, silver mica, .001 $\mu$ f, $\pm$ 5%, 500 vdcw	15-57	A 1464TT
C59	Capacitor: variable, ceramic dielectric 7-45 $\mu$ $\mu$ f	13-1	L, TS2A
C60	Capacitor: fixed, ceramic dielectric, 82 $\mu$ $\mu$ f, $\pm$ 5%, 500 vdcw	15-7	L NPO 333
C61	Same as C59		
C62	Capacitor: fixed, ceramic dielectric, 82 $\mu$ $\mu$ f, $\pm$ 5%, 500 vdcw	15-7	L NPO 333
C63	Capacitor: fixed, mica, 22 $\mu$ $\mu$ f, $\pm$ 5%, 300 vdcw	14-69	V Type PQ
C64	Capacitor: variable, trimmer, ceramic, 5-25 $\mu$ $\mu$ f	13-28 1A	L Style 557-23
C65	Capacitor: variable, trimmer, ceramic, 3-12 $\mu$ $\mu$ f	13-29 38A	L Style 557-23
C66	Capacitor: fixed, ceramic dielectric, 5 $\mu$ $\mu$ f, $\pm$ 0.5 $\mu$ $\mu$ f, 500 vdcw	15-29	K 35 CI-1

\* See "List of Manufacturers Code Letters for Replaceable Parts Table".

**TABLE OF REPLACEABLE PARTS**

Circuit Ref.	Description	Ⓟ Stock No.	Mfr. * & Mfrs. Designation
C67	Capacitor: variable, trimmer, ceramic, 1.5 - 7 $\mu$ f	13-27	L Style 557-23
CR3	Crystal, rectifier, selected	212-G11A	BU, HD-2135
CR4	Crystal, rectifier, germanium diode 1N38A	212-1N38A	EE 1N38A
CR7	Crystal, rectifier	212-G11A	BU, HD 2135
CR8	Crystal, rectifier, germanium diode	212-G12	Transitron 1N116 selected
I1, I2	Neon, selected: (red coding)	G-84E	HP
I3, I4, I5, I6	Neon, selected: (blue coding)	G-84B	HP
	<p>NOTE: I1, I2, I3, I4, I5; these neon lamps are polarized and must be installed with the painted side connected to the positive voltage.</p>		

\* See "List of Manufacturers Code Letters for Replaceable Parts Table".

TABLE OF REPLACEABLE PARTS

Circuit Ref.	Description	Stock No.	Mfr. * & Mrs. Designation
<u>SWEEP GENERATOR (CONT'D.)</u>			
I7	NE 2 neon, selected, 1/25 W	G-84B	HP
I8	Neon, selected: (green coding)	G-84D	HP
I9	Same as I7		
I12	Lamp, incandescent, 6V., 1 C. P.	211-170	O, Type 51
J3	Consists of: Binding post, red (1) Binding post, black (1) Insulator (2)	G-10D G-10C G-83A	HP HP HP
J4	Connector: BNC	125-9	LL, 5126
J8, J9, J10	Socket, electric tube, 9 pin, miniature type	G-76D	EE, 7490-0070
L8	Coil, choke, 10 $\mu$ h, $\pm 10\%$ , layer wound	48-54	CG, 217-21
L10, L11	Coil, R. F., 35 $\pm 10\%$ $\mu$ h	48-42	CG, 1035-15
L12	Coil, R. F., 100 $\mu$ h	150A-60A	HP
L13	Coil, R. F., 270 $\mu$ h	150A-60G	HP
L14	Coil, R. F., 20 $\mu$ h	150A-60E	HP
R51, R52	Resistor: fixed, composition, 680,000 ohms, $\pm 10\%$ , 1/2 W	23-680K	B EB 6841
R53	Resistor: fixed, composition, 270,000 ohms, $\pm 10\%$ , 1/2 W	23-270K	B EB 2741
R54	Resistor: fixed, composition, 220,000 ohms, $\pm 10\%$ , 1/2 W	23-220K	B EB 2241
R55	Resistor: fixed, composition, 1 megohm, $\pm 10\%$ , 1/2 W	23-1M	B EB 1051
R56	Resistor: fixed, composition, 2.2 megohms, $\pm 10\%$ , 1/2 W	23-2.2M	B EB 2251
R57	See Z14		
R58	Resistor: fixed, composition, 47,000 ohms, $\pm 10\%$ , 1/2 W	23-47K	B EB 4731
R59	Resistor: fixed, composition, 470,000 ohms, $\pm 10\%$ , 1/2 W	23-470K	B EB 4741
R60	Resistor: fixed, composition, 56 ohms, $\pm 10\%$ , 1/2 W	23-56	B EB 5601
R61, R62	Resistor: fixed, composition, 2200 ohms, $\pm 10\%$ , 1 W	24-2200	B GB 2201
R63	Resistor: fixed, non-inductive metal film on glass rod body, 20,000 ohms, $\pm 10\%$ , 4 W	334-20K	AB LP-4
R64, R65	Resistor: fixed, composition, 56 ohms, $\pm 10\%$ , 1/2 W	23-56	B EB 5601

\*See "List of Manufacturers Code Letters for Replaceable Parts Table".

**TABLE OF REPLACEABLE PARTS**

Circuit Ref.	Description	Stock No.	Mfr. * & Mfrs. Designation
<u>SWEEP GENERATOR (CONT'D.)</u>			
R66	Resistor: variable, composition, linear taper 2000 ohms, $\pm 30\%$ , 1/3 W	210-133	BO UPE-70 special
R67	This circuit reference not assigned.	-----	-----
R68	Resistor: fixed, composition, 1800 ohms, $\pm 10\%$ , 1/2 W	23-1800	B EB 1821
R69	Resistor: fixed, non-inductive metal film type on glass rod body, 10,000 ohms, $\pm 5\%$ , 4 W	334-10K	AB LP-4
R70	Resistor: fixed, deposited carbon, 200,000 ohms, $\pm 5\%$ , 1/2 W	33-200K	NN DC-1/2 A
R71	Resistor: fixed, deposited carbon, 526,000 ohms, $\pm 1\%$ , 1 W	31-526K	NN DC-1
R72	Resistor: variable, composition, linear taper, 100,000 ohms, $\pm 30\%$ , 1/4 W	210-138	BO UPE-70 special
R73, R74	This circuit reference not assigned	-----	-----
R75	Resistor: fixed, metal film on glass body, 6500 ohms, $\pm 5\%$ , 3 W	333-6500-5	AB LP-3
R76	Resistor: fixed, glass body, 10,000 ohms, $\pm 5\%$ , 3 W	333-10K-5	AB LP-3
R77	Resistor: fixed, composition, 100 ohms, $\pm 10\%$ , 1/2 W	23-100	B EB 1011
R78	Resistor: fixed, composition, 56 ohms, $\pm 10\%$ , 1/2 W	23-56	B EB 5601
R79, R80	Resistor: fixed, deposited carbon, 37,000 ohms, $\pm 1\%$ , 1 W	31-37K	NN DC-1
R81	Resistor: fixed, composition, 56 ohms, $\pm 10\%$ , 1/2 W	23-56	B EB 5601
R82	Resistor: fixed, composition, 1000 ohms, $\pm 10\%$ , 1/2 W	23-1000	B EB 1021
R83	Resistor: fixed, deposited carbon, 37,000 ohms, $\pm 1\%$ , 1 W	31-37K	NN DC-1
R84	Resistor: fixed, composition, 68,000 ohms, $\pm 5\%$ , 1 W	24-68K-5	B GB 6835
R85	Resistor: fixed, composition, 560,000 ohms, $\pm 10\%$ , 1/2 W	23-560K	B EB 5641
R86	Resistor: fixed, composition, 180,000 ohms, $\pm 10\%$ , 1/2 W	23-180K	B EB 1841
R87	Resistor: fixed, composition, 56 ohms, $\pm 10\%$ , 1/2 W	23-56	B EB 5601
R88	This circuit reference not assigned	-----	-----

\* See "List of Manufacturers Code Letters for Replaceable Parts Table".

TABLE OF REPLACEABLE PARTS

Circuit Ref.	Description	Ⓢ Stock No.	Mfr. * & Mfrs. Designation
	<u>SWEEP GENERATOR (CONT'D.)</u>		
R89	Resistor: fixed, composition, 47,000 ohms, ±10%, 2 W	25-47K	B HB 4731
R90	Resistor: fixed, composition, 56 ohms, ±10%, 1/2 W	23-56	B EB 5601
R91	Resistor: fixed, non-inductive metal film on glass rod body, 30,000 ohms, ±10%, 4 W	334-30K	AB LP-4
R92	Resistor: fixed, composition, 180,000 ohms, ±10%, 1/2 W	23-180K	B EB 1841
R93	Resistor: fixed, composition, 56 ohms, ±10%, 1/2 W	23-56	B EB 5601
R94	Resistor: fixed, composition, 5600 ohms, ±10%, 1/2 W	23-5600	B EB 5621
R95	Resistor: fixed, glass body, 56,000 ohms, ±10%, 5 W	335-56K	AB LP-5
R96	Resistor: fixed, composition, 22,000 ohms, ±10%, 1/2 W	23-22K	B EB 2231
R97	Resistor: fixed, composition, 56 ohms, ±10%, 1/2 W	23-56	B EB 5601
R98	Resistor: fixed, composition, 330,000 ohms, ±10%, 1/2 W	23-330K	B EB 3341
R99	Resistor: fixed, composition, 82,000 ohms, ±10%, 1/2 W	23-82K	B EB 8231
R100	See Z15		
R101	Resistor: fixed, composition, 390,000 ohms, ±10%, 1/2 W	23-390K	B EB 3941
R102	Resistor: fixed, composition, 22,000 ohms, ±10%, 1/2 W	23-22K	B EB 2231
R103	Resistor: variable, composition, linear taper, 20,000 ohms, ±20%, 1/4 W	210-136	BO UPE-70 special
R104	Resistor: fixed, composition, 82,000 ohms, ±10%, 1/2 W	23-82K	B EB 8231
R105	Resistor: fixed, composition, 33,000 ohms, ±10%, 1/2 W	23-33K	B EB 3331
R106	Resistor: fixed, composition, 270,000 ohms, ±10%, 1/2 W	23-270K	B EB 2741
R107	Resistor: fixed, composition, 27,000 ohms, ±10%, 2 W	25-27K	B EB 2731
R108	Resistor: fixed, composition, 56 ohms, ±10%, 1/2 W	23-56	B EB 5601

\* See "List of Manufacturers Code Letters for Replaceable Parts Table".

**TABLE OF REPLACEABLE PARTS**

Circuit Ref.	Description	Stock No.	Mfr. * & Mfrs. Designation
<u>SWEEP GENERATOR (CONT'D.)</u>			
R109	Resistor: fixed, composition, 27,000 ohms, ±10%, 2 W	25-27K	B EB 2731
R110	Resistor: fixed, deposited carbon, 166,000 ohms, ±1%, 1 W	31-166K	NN DC-1
R111	Resistor: fixed, composition, 56 ohms, ±10%, 1/2 W	23-56	B EB 5601
R112	Resistor: fixed, deposited carbon, 90,000 ohms, ±1%, 1 W	31-90K	NN DC-1
R113, R114	Resistor: fixed, composition, 4.7 megohms, ±10%, 1/2 W	23-4.7M	B EB 4751
R115	Resistor: fixed, composition, 56 ohms, ±10%, 1/2 W	23-56	B EB 5601
R116	Resistor: fixed, composition, 22,000 ohms, ±10%, 1/2 W	23-22K	B EB 2231
R117	Resistor: fixed, composition, 390,000 ohms, ±10%, 1/2 W	23-390K	B EB 3941
R118	Resistor: fixed, composition, 22,000 ohms, ±10%, 1/2 W	23-22K	B EB 2231
R119	Resistor: fixed, composition, 30,000 ohms, ±5%, 2 W	25-30K-5	B HB 3035
R120	Resistor: fixed, composition, 56 ohms, ±10%, 1/2 W	23-56	B EB 5601
R121	Resistor: fixed, metal film on glass body, 20,000 ohms, ±1%, 2 W	333-20K	AB N-30
R122	Resistor: variable, composition, linear taper, 10,000 ohms, ±20%, 1/4 W	210-135	BO UPE-70 special
R123	Resistor: fixed, glass body, 15,000 ohms, ±5%, 4 W	334-15K-5	AB LP-4
R124	Resistor: fixed, composition, 470,000 ohms, ±10%, 1/2 W	23-470K	B EB 4741
R125	Resistor: fixed, composition, 1.2 megohms, ±10%, 1/2 W	23-1.2M	B EB 1251
R126	Resistor: fixed, composition, 820,000 ohms, ±10%, 1/2 W	23-820K	B EB 8241
R127	Resistor: fixed, composition, 56 ohms, ±10%, 1/2 W	23-56	B EB 5601
R128	Resistor: fixed, composition, 47,000 ohms, ±10%, 2 W	25-47K	B HB 4731
R129	Resistor: fixed, composition, 330,000 ohms, ±10%, 1/2 W	23-330K	B EB 3341

\*See "List of Manufacturers Code Letters for Replaceable Parts Table".

TABLE OF REPLACEABLE PARTS

Circuit Ref.	Description	Stock No.	Mfr. * & Mfrs. Designation
<u>SWEEP GENERATOR (CONT'D.)</u>			
R130, R131	Resistor: fixed, composition, 56 ohms, $\pm 10\%$ , 1/2 W	23-56	B EB 5601
R132	Resistor: fixed, composition, 47 ohms, $\pm 10\%$ , 2 W	25-47	B HB 4701
R133	Resistor: fixed, composition, 1200 ohms, $\pm 10\%$ , 1/2 W	23-1200	B EB 1221
R134	Resistor: fixed, composition, 1000 ohms, $\pm 10\%$ , 1/2 W	23-1000	B EB 1021
R135, R136, R137, R138, R139, R140	These circuit references not assigned	-----	-----
R141	Resistor: fixed, composition, 470,000 ohms, $\pm 10\%$ , 1/2 W	23-470K	B EB 4741
R142	Resistor: fixed, composition, 150,000 ohms, $\pm 10\%$ , 1/2 W	23-150K	B EB 1541
R143, R144, R145	Resistor: variable, composition, linear taper, 10,000 ohms, $\pm 20\%$ , 1/4 W	210-135	BO UPE-70 special
R146	See Z13		
R147	Resistor: fixed, composition, 15,000 ohms, $\pm 10\%$ , 1/2 W	23-15K	B EB 1531
R148	Resistor: fixed, deposited carbon, 36 megohms, $\pm 1\%$ , 2 W	32-36M	K CP-2
R149, R150	Resistor: fixed, deposited carbon, 12 megohms, $\pm 1\%$ , 1 W	31-12M	NN DC-1
R151	Resistor: fixed, deposited carbon, 3.6 megohms, $\pm 1\%$ , 1/2 W	33-3.6M	NN DC-1/2B
R152, R153	Resistor: fixed, deposited carbon, 1.2 megohms, $\pm 1\%$ , 1/2 W	33-1.2M	NN DC-1/2B
R154	Resistor: fixed, deposited carbon, 360,000 ohms, $\pm 1\%$ , 1/2 W	33-360K	NN DC-1/2 B
R155, R156	Resistor: fixed, deposited carbon, 120,000 ohms, $\pm 1\%$ , 1/2 W	33-120K	NN DC-1/2B
R157	Resistor: variable, composition, linear taper, 10,000 ohms, $\pm 20\%$ , 1/4 W	210-135	BO UPE-70 special
R158, R159	Resistor: fixed, composition, 56,000 ohms, $\pm 10\%$ , 1/2 W	23-56K	B EB 5631
S1, S3	See Z15		
S2	Switch, rotary, 1M pot.	310-180	W, 73214-NIP
S4	Switch, slide DPDT	310-183	AT, 4603
S5, S6	See Z13		

\*See "List of Manufacturers Code Letters for Replaceable Parts Table".



TABLE OF REPLACEABLE PARTS

Circuit Ref.	Description	Stock No.	Mfr. * & Mfrs. Designation
<u>SWEEP GENERATOR (CONT'D.)</u>			
T4	Neutralizing transformer	150A-60I	HP
V8, V9, V10, V11, V12,	Tube: 6BQ7A	212-6BQ7A	ZZ (RCA preferred)
V13	Tube: 6AL5	212-6AL5	ZZ
V14	Tube: 6485 or 6AH6	212-6485 or 212-6AH6	ZZ ZZ
V15	Tube: 6BK7A	212-6BK7A	ZZ
V16, V17	Tube: 6BQ7A	212-6BQ7A	ZZ
XI6	Lampholder with jewel, gate up indicator	145-19	AD D223H-AHN814L- 15
XII2	Lampholder	145-20	AP, 214J-FE
XV8, XV9, XV10, XV11, XV12,	Socket: tube, 9 pin miniature type.	120-49	H, 20907
XV13, XV14	Socket: tube, 7 pin miniature type.	120-48	H, 20906
XV15, XV16, XV17	Socket: tube, 9 pin miniature type.	120-49	H, 20907
Z11	Sync & Sweep Generator Assembly	150A-65A	HP
Z12	Etched Circuit Assembly	150A-95B	HP
Z13	Sweep Time/CM Selector Switch Assembly	150A-19A	HP
Z14	Trigger Slope Selector Switch	150A-19B	HP
Z15	Sync Selector Switch Assembly	150A-19C	HP
	Knob, 1-5/8", bar, skirted black (2)	G-74Q	HP
	Knob, 3/4", with arrow, red (1)	G-74AU	HP
	Knob, 1-5/8", knurled skirted black (1)	G-74L	HP
	Knob, 3/4", bar, red (1)	G-74AT	HP
	Knob, 3/4", red (1)	G-74AW	HP
	Rod, light	150A-37A	HP
	Insulator, standoff, ceramic	150A-54A	HP

\* See "List of Manufacturers Code Letters for Replaceable Parts Table".

**TABLE OF REPLACEABLE PARTS**

Circuit Ref.	Description	 Stock No.	Mfr. * & Mrs. Designation
	<u>HORIZONTAL AMPLIFIER</u>		
C71, C72	Capacitor: variable, trimmer, ceramic, 1.5-7 $\mu$ f	13-27	L Style 557-23
C73	Capacitor: fixed, mica, 47 $\mu$ f, $\pm$ 5%, 300 vdcw	14-74	V Type PQ
C74	Same as C71		V, Type OXM
C75	Capacitor: variable, trimmer, ceramic, 5-25 $\mu$ f, NPO temp. coeff.	13-28	L Style 557-23
C76	Capacitor: fixed, ceramic dielectric, .01 $\mu$ f, tol. +100%, -0%, 1000 vdcw	15-43	CC 36C99
C77, C78	Capacitor: variable, ceramic, with slotted head shaft, 8-50 $\mu$ f, N750 temp. coeff.	13-23	L Style 557
C79	Capacitor: fixed, mica, 82 $\mu$ f, $\pm$ 10%, 500 vdcw	14-19	V, Type OXM
C80	Capacitor: variable, trimmer, ceramic, 1.5-7 $\mu$ f, NPO temp. coeff.	13-27	L Style 557-23
C81	Capacitor: fixed, mica, 820 $\mu$ f, $\pm$ 10%, 500 vdcw	14-28	V, Type OXM
C82	Capacitor: fixed, titanium dioxide, 8.2 $\mu$ f, $\pm$ 10%, 500 vdcw	15-123	DD Type GA
C83	Capacitor: fixed, titanium dioxide dielectric, 1 $\mu$ f, $\pm$ 10%, 500 vdcw	15-102	DD Type GA
C84	Capacitor: variable, ceramic dielectric, 7-45 $\mu$ f	13-1	L, TS2A
C85	Capacitor: variable, clip 0-.5	150A-7A	HP
C86	Capacitor: variable, ceramic dielectric, 5-20 $\mu$ f, 500 vdcw	13-20	L TS2A-N300
C87	Capacitor: fixed, mica, 150 $\mu$ f, $\pm$ 10%, 500 vdcw	14-150	V, Type OXM
C88	Capacitor: variable, ceramic dielectric, 7-45 $\mu$ f	13-1	L, TS2A
C89	Capacitor: variable, clip, 0-.5	150A-7A	HP
C90, C91	Capacitor: fixed, mica, .01 $\mu$ f, $\pm$ 10%, 300 vdcw	14-23	V, Type W
C92, C93, C94	Capacitor: fixed, ceramic disc, .02 $\mu$ f, tol. +100%, -0%, 600 vdcw	15-85	G DD-203
C95, C96	Capacitor: fixed, titanium dioxide, 8.2 $\mu$ f, $\pm$ 10%, 500 vdcw	15-123	DD Type GA
I11	Lamp, incandescent, G. E. -51	211-70	O, Type 51
I13, I14, I15, I16	Neon, selected: (blue coding)	G-84B	HP
I17, I18, I19, I20, I21, I22, I23, I24	Neon, selected, (pairs)	G-84C	HP
J11	Connector, BNC	125-9	LL, 5126

\* See "List of Manufacturers Code Letters for Replaceable Parts Table"

TABLE OF REPLACEABLE PARTS

Circuit Ref.	Description	Stock No.	Mfr. * & Mfrs. Designation
	<u>HORIZONTAL AMPLIFIER (CONT'D.)</u>		
J12	Banana Plug connector, female, 3/4" spacing; consists of:  Binding post, black Binding post, red Insulator plate	G-10C G-10D G-83A	HP HP HP
J13, J14, J15	Socket, electric tube, 9 pin miniature type	G-76D	EE, 7490-0070
L15, L16	Coil, R.F., 5.5 mh	150A-60B	HP
L17, L18	Coil, R.F., 35 ±10% μh	48-42	CG, 1035-15
R171	Resistor: fixed, deposited carbon, 900,000 ohms, ±1%, 1/2 W	33-900K	NN DC-1/2 A
R172	Resistor: fixed, deposited carbon, 111,000 ohms, ±1%, 1/2 W	33-111K	NN DC-1/2A
R173	Resistor: fixed, deposited carbon, 1 megohm, ±1%, 1/2 W	33-1M	NN DC-1/2A
R174	Resistor: fixed, composition, 56 ohms, ±10%, 1/2 W	23-56	B EB 5601
R175	Resistor: fixed, composition, 18,000 ohms, ±10%, 1 W	24-18K	B GB 1831
R176	Resistor: fixed, composition, 27,000 ohms, ±10%, 2 W	25-27K	B HB 2731
R177	Resistor: variable, composition, 10,000 ohms, ±30%, 1/2 W	210-161	BO, RGC-45
R178	Resistor: variable, composition, linear taper, 2000 ohms, ±30%, 1/3 W	210-133	BO UPE-70 special
R179, R180	Resistor: fixed, 33,000 ohms, 2 W	25-33K	B, HB 3331
R181	Resistor: fixed, deposited carbon, 100,000 ohms, ±1%, 1 W	31-100K	NN DC-1
R182	Resistor: fixed, composition, 56 ohms, ±10%, 1/2 W	23-56	B EB 5601
R183	Resistor: fixed, composition, 47,000 ohms, ±10%, 1/2 W	23-47K	B EB 4731
R184	Resistor: fixed, composition, 1 megohm, ±10%, 1/2 W	23-1M	B EB 1051
R185	Resistor: variable, composition, <sup>BO</sup> linear taper potentiometer, 1 megohm, ±30%, 1/4 W	210-139	BO UPE-70 special
R186	Resistor: variable, 50,000 ohms, ±5%, 3W	210-169	Helipot 50K-CZ
R187	Resistor: fixed, deposited carbon, 166,000 ohms, ±1%, 1W	31-166K	NN DC-1
R188	Resistor: fixed, deposited carbon, 123,000 ohms, ±1%, 1W	31-123K	NN DC-1

\* See "List of Manufacturers Code Letters for Replaceable Parts Table".

TABLE OF REPLACEABLE PARTS

Circuit Ref.	Description	Ⓟ Stock No.	Mfr. * & Mfrs. Designation
<u>HORIZONTAL AMPLIFIER (CONT'D.)</u>			
R189	Resistor: variable, composition, linear taper, potentiometer, 500,000 ohms, $\pm 30\%$ , 1/4W	210-146	BO U-70 special
R190	Resistor: fixed, composition, 220,000 ohms, $\pm 10\%$ , 1/2 W	23-220K	B EB 2241
R191	Resistor: fixed, composition, 62,000 ohms, $\pm 1\%$ , 1W	31-62K	NN DC-1
R192	Resistor: fixed, carbon film on ceramic body, 15.2K ohms, $\pm 1\%$ , 1 W	31-15.2K	NN DC-1
R193	Resistor: fixed, composition, 92.6K ohms, $\pm 1\%$ , 1/2 W	33-92.6K	NN DC-1/2C
R194	Resistor: fixed, carbon film on ceramic body 193,000 ohms, $\pm 1\%$ , 1 W	31-193	NN DC-1
R195	Resistor: fixed, composition, 1800 ohms, $\pm 10\%$ , 1/2 W	23-1800	B EB 1821
R196	Resistor: fixed, deposited carbon, 2.163 megohms, $\pm 1\%$ , 1 W	31-2.163M	NN DC-1
R197	Resistor: fixed, composition, 56 ohms, $\pm 10\%$ , 1/2 W	23-56	B EB 5601
R198	Resistor: fixed, deposited carbon, 83,000 ohms, $\pm 1\%$ , 1 W	31-83K	NN DC-1
R199	Resistor: variable, composition, linear taper, potentiometer, 500,000 ohms, $\pm 30\%$ , 1/4W	210-146	BO U-70 special
R200	Resistor: fixed, metal film on glass rod body, 38,000 ohms, $\pm 10\%$ , 4 W	334-38K	AB LP-4
R201	Resistor: fixed, composition, 680,000 ohms, $\pm 10\%$ , 1/2 W	23-680K	B EB 6841
R202	Resistor: fixed, composition, 100,000 ohms, $\pm 10\%$ , 1/2 W	23-100K	B EB 1041
R203	Resistor: fixed, composition, 33,000 ohms, $\pm 10\%$ , 2 W	25-33K	B EB 3331
R204	Resistor: fixed, composition, 56 ohms, $\pm 10\%$ , 1/2 W	23-56	B EB 5601
R205	Resistor: fixed, metal film on glass body, 11,000 ohms, $\pm 5\%$ , 4 W	334-11K-5	AB LP-4
R206	Resistor: fixed, composition, 33,000 ohms, $\pm 10\%$ , 2 W	25-33K	B EB 3331
R207	Resistor: variable, composition, linear taper 50,000 ohms, $\pm 20\%$ , 1/2 W	210-124	BO Type UPM-45
R208, R209	Resistor: fixed, metal film on glass body, 20,000 ohms, $\pm 1\%$ , 2 W	332-20K	AB N-30

\*See "List of Manufacturers Code Letters for Replaceable Parts Table".

**TABLE OF REPLACEABLE PARTS**

Circuit Ref.	Description	Ⓢ Stock No.	Mfr. * & Mfrs. Designation
	<u>HORIZONTAL AMPLIFIER (CONT'D.)</u>		
R210	Resistor: fixed, composition, 56 ohms, ±10%, 1/2 W	23-56	B EB 5601
R211	Resistor: fixed, metal film on glass body, 11,000 ohms, ±5%, 4 W	334-11K-5	AB LP-4
R212	Resistor: fixed, composition, 47,000 ohms, ±10%, 1 W	24-47K	B GB 4731
R213	Resistor: variable, potentiometer, 250 ohms, ±20%, 1/4 W	210-176	BO UPE-70
R214	Resistor: fixed, carbon film on ceramic body, 11.88K ohms, ±1%, 1/2 W	33-11.88K	NN DC-1/2C
R215	Resistor: fixed, carbon film on ceramic body, 2030 ohms, ±1%, 1/2 W	33-2030	NN DC-1/2C
R216	Resistor: fixed, deposited carbon, 4860 ohms, ±1%, 1/2 W	33-4860	NN DC-1/2B
R217	Resistor: fixed, deposited carbon, 490 ohms, ±1%, 1/2 W	33-490	NN DC-1/2C
R218,	Resistor: fixed, deposited carbon, 30.5K ohms, ±1%, 1 W	31-30.5K	NN DC-1
R219	Resistor: fixed, deposited carbon, potted, 80,000 ohms, ±1%, 1 W	150A-95A	HP
R220	Resistor: fixed, composition, 56 ohms, ±10%, 1/2 W	23-56	B EB 5601
R221	Resistor: fixed, non-inductive metal film on glass rod body, 30,000 ohms, ±10%, 4 W	334-30K	AB LP-4
R222	Resistor: fixed, composition, 56 ohms, ±10%, 1/2 W	23-56	B EB 5601
R223	Resistor: fixed, deposited carbon, 30.5K ohms, ±1%, 1 W	31-30.5K	NN DC-1
R224	Resistor: fixed, deposited carbon, potted, 80,000 ohms, ±1%, 1 W	150A-95A	HP
R225	Resistor: fixed, non-inductive metal film on glass rod body, 30,000 ohms, ±10%, 4 W	334-30K	AB LP-4
R226	Resistor: fixed, composition, 56 ohms, ±10%, 1/2 W	23-56	B EB 5601
R227	Resistor: fixed, composition, 100,000 ohms, ±5%, 1/2 W	23-100K	B EB 1045
R228, R229	Resistor: fixed, composition, 680,000 ohms, ±10%, 1/2 W	23-680K	B EB 6841
R230	Resistor: fixed, wirewound, 3500 ohms, ±10%, 20 W	27-43	AS

\* See "List of Manufacturers Code Letters for Replaceable Parts Table"

**TABLE OF REPLACEABLE PARTS**

Circuit Ref.	Description	Ⓟ Stock No.	Mfr. * & Mfrs. Designation
<u>HORIZONTAL AMPLIFIER (CONT'D.)</u>			
R231	Resistor: fixed, composition, 100,000 ohms, ±5%, 1/2 W	23-100K	B EB 1045
R232	Resistor: fixed, composition, 56 ohms, ±10%, 1/2 W	23-56	B EB 5601
R233	Resistor: fixed, wirewound, 12,000 ohms, ±10%, 20 W	27-44	AS
R234	Resistor: fixed, composition, 56 ohms, ±10%, 1/2 W	23-56	B EB 5601
R235	Resistor: fixed, deposited carbon, 30.5K ohms, ±1%, 1 W	31-30.5K	NN DC-1
R236	Resistor: fixed, composition, 56 ohms, ±10%, 1/2 W	23-56	B EB 5601
R237	Resistor: fixed, composition, 470 ohms, ±10%, 1/2 W	23-470	B EB 4711
R238	Resistor: fixed, composition, 56 ohms, ±10%, 1/2 W	23-56	B EB 5601
R239	Resistor: fixed, composition, 2700 ohms, ±10%, 1/2 W	23-2700	B EB 2721
R240, R241	Resistor: fixed, composition, 2200 ohms, ±10%, 1/2 W	23-2200	B EB 2221
R242	Resistor: fixed, composition, 2700 ohms, ±10%, 1/2 W	23-2700	B EB 2721
R243	Resistor: fixed, composition, 56 ohms, ±10%, 1/2 W	23-56	B EB 5601
R244, R245	Resistor: fixed, composition, 100,000 ohms, ±10%, 2 W	25-100K	B HB 1041
R246	Resistor: fixed, composition, 56 ohms, ±10%, 1/2 W	23-56	B EB 5601
R247	Resistor: fixed, composition, 2700 ohms, ±10%, 1/2 W	23-2700	B EB 2721
S7	See Z19		
S8	Part of R177	210-161	BO, Type CG-33
V18, V19	Tube: 6BQ7A	212-6BQ7A	ZZ
V20, V21	Tube: 6485 or 6AH6	212-6485 or 212-6AH6	ZZ ZZ
V22	Tube: 6BQ7A	212-6BQ7A	ZZ
V23, V24	Tube: 6197 or 6CL6	212-6197 or 212-6CL6	ZZ
V25, V26	Tube: 6BQ7A	212-6BQ7A	ZZ

\* See "List of Manufacturers Code Letters for Replaceable Parts Table".

TABLE OF REPLACEABLE PARTS

Circuit Ref.	Description	 Stock No.	Mfr. * & Mfrs. Designation
<u>HORIZONTAL AMPLIFIER (CONT'D.)</u>			
XI11	Lampholder, miniature type.	145-20	AD, 214J-FE
XV18, XV19	Socket, tube 9 pin miniature type.	120-49	H, 20907
XV20, XV21	Socket, tube, 7 pin miniature type.	120-48	H, 20906
XV22	Socket, tube, 9 pin miniature type.	120-49	H, 20907
XV23, XV24	Tube: 6197 or 6CL6	212-6197 or 212-6CL6	ZZ ZZ
Z17	Complete Horizontal Amplifier	150A-65B	HP
Z18	Etched Circuit Assembly	150A-95C	HP
Z19	Horizontal Sensitivity Selector Switch	150A-19D	HP
	Insulator, ceramic stand-off, 3/4" x 3/8"	34-34	AI, 1023-04-3/4"
	Rod, light, for I11, 1/8" diameter.	150A-37A	Plastic Center Specialty Co.
	Fuse clip, holds 20 W resistor	140-21	T, 125002
	Knob, 1-5/8", skirted, black (2)	G-74K	HP
	Knob, 1-5/8", bar, skirted, black (1)	G-74N	HP

\* See "List of Manufacturers Code Letters for Replaceable Parts Table".

TABLE OF REPLACEABLE PARTS

Circuit Ref.	Description	Stock No.	Mfr. * & Mrs. Designation
<u>CALIBRATOR AND HIGH VOLTAGE</u>			
C101	Capacitor: fixed, paper dielectric, .0022 $\mu$ f, $\pm 10\%$ , 600 vdcw	16-22	CC 109P22296
C102	Capacitor: fixed, paper dielectric, 0.1 $\mu$ f, $\pm 10\%$ , 600 vdcw	16-1	CC 109P10496
C103	Capacitor: fixed, mica, 3300 $\mu$ f, $\pm 10\%$ , 500 vdcw	14-64	V Type W
C104	Capacitor: fixed, mica, 820 $\mu$ f, $\pm 10\%$ , 500 vdcw	14-28	V Type OXM
C105	Capacitor: fixed, paper dielectric, .0047 $\mu$ f, $\pm 20\%$ , 6000 vdcw	16-75	CC 84P472060
C106	Capacitor: fixed, paper dielectric, .082 $\mu$ f, $\pm 10\%$ , 600 vdcw	16-70	CC 109P82396
C107	Capacitor: fixed, mica, 220 $\mu$ f, $\pm 10\%$ , 500 vdcw	14-66	Z Type K1322
C108	Capacitor: variable, ceramic dielectric, 7-45 $\mu$ f	13-1	L TS2A
C109, C110, C111	Capacitor: fixed, paper dielectric, .0047 $\mu$ f, $\pm 20\%$ , 6000 vdcw	16-75	CC 84P472060
C112	Capacitor: fixed, ceramic, 470 $\mu$ f, $\pm 20\%$ , 6000 vdcw	15-128	Y
C113 B, C C114	Capacitor: fixed, paper dielectric, .0047 $\mu$ f, $\pm 20\%$ , 6000 vdcw	16-75	CC 84P472060
C115	Capacitor: fixed, ceramic dielectric, .01 $\mu$ f, tol. +100%, -0%, 1000 vdcw	15-43	CC 36C99
C116, C117	Capacitor: fixed, silver mica, 220 $\mu$ f, $\pm 5\%$ , 500 vdcw	15-76	V Type RQ
C118	Capacitor: fixed, ceramic dielectric, .01 $\mu$ f, tol. +100%, -0%, 1000 vdcw	15-43	CC 36C99
C119	Capacitor: fixed, mica, 15 $\mu$ f, $\pm 10\%$ , 500 vdcw	14-15	V Type Q
CR1	Crystal, rectifier, type 1N55	212-1N55	EE, 1N55A
CR2	Crystal, rectifier	212-G11A	BU, HD 2135
J17	Banana plugs spaced 3/4"; consists of: Binding post, black (2) Binding post insulator, single, black Binding post insulator, black	G-10C G-83G G-83A	HP HP HP
J18	Banana plug, single; consists of: Binding post, black (1) Binding post insulator, single, black (2)	G-10C G-83G	HP HP

\*See "List of Manufacturers Code Letters for Replaceable Parts Table".



**TABLE OF REPLACEABLE PARTS**

Circuit Ref.	Description	Ⓜ Stock No.	Mfr. * & Mrs. Designation
<u>CALIBRATOR AND HIGH VOLTAGE (CONT'D.)</u>			
J19, J20, J21	Socket, electric tube, 9 pin miniature type	G-76D	HP
R261	Resistor: fixed, composition, 330 ohms, $\pm 10\%$ , 1/2 W	23-330	B EB 3311
R262	Resistor: fixed, composition, 3300 ohms, $\pm 10\%$ , 1/2 W	23-3300	B EB 3321
R263	Resistor: fixed, composition, 270,000 ohms, $\pm 10\%$ , 1/2 W	23-270K	B EB 2741
R264	Resistor: fixed, composition, 56,000 ohms, $\pm 10\%$ , 1/2 W	23-56K	B EB 5631
R265	Resistor: variable, composition, 3.5 megohms, $\pm 30\%$ , 1/2 W	210-150	I
R266	Resistor: fixed, wirewound, 50 megohms, $\pm 10\%$ , 2 W	26-81	AV Type BBM
R267	Resistor: fixed, composition, 33,000 ohms, $\pm 10\%$ , 1/2 W	23-33K	B EB 3331
R268	Resistor: fixed, composition, 1 megohm, $\pm 10\%$ , 1/2 W	23-1M	B EB 1051
R269	Resistor: fixed, composition, 100,000 ohms, $\pm 10\%$ , 1/2 W	23-100K	B EB 1041
R270	Resistor: fixed, metal film on glass rod body, 38,000 ohms, $\pm 10\%$ , 4 W	334-38K	AB LP-4
R271	Resistor: fixed, composition, 330,000 ohms, $\pm 10\%$ , 1/2 W	23-330K	B EB 3341
R272	Resistor: fixed, composition, 150,000 ohms, $\pm 10\%$ , 1/2 W	23-150K	B EB 1541
R273	Resistor: fixed, composition, 100,000 ohms, $\pm 10\%$ , 1 W	24-100K	B GB 1041
R274	Resistor: fixed, composition, 2.52 megohms, $\pm 1\%$ , 1 W	31-2.52M	NN DC-1
R275	Resistor: variable, composition, potentiometer, 3.5 megohms, $\pm 30\%$ , 1/4 W	210-144	BO UPM-45
R276	Resistor: fixed, wirewound, 50 megohms, $\pm 10\%$ , 2 W	26-81	AV Type BBM
R277	Resistor: variable, composition, potentiometer, 5 megohms, $\pm 30\%$ , 1/2 W	210-159	I 37, HV Insulator
R278	Resistor: fixed, deposited carbon, 4.15 megohms $\pm 1\%$ , 1W. Factory adjustment; may vary from 3.3 megohms to 5.2 megohms.	31-4.15M	NN DC-1
R279	Resistor: fixed, composition, 27,000 ohms, $\pm 10\%$ , 1/2 W	23-27K	B EB 2731

\* See "List of Manufacturers Code Letters for Replaceable Parts Table".

**TABLE OF REPLACEABLE PARTS**

Circuit Ref.	Description	Stock No.	Mfr. * & Mfrs. Designation
<u>CALIBRATOR AND HIGH VOLTAGE (CONT'D.)</u>			
R280, R281, R282	Resistor: fixed, composition, 1 megohm, $\pm 10\%$ , 1/2 W	23-1M	B EB 1051
R283	Resistor: variable, composition, potentiometer, 500,000 ohms, $\pm 20\%$	210-20	G
R284	Resistor: fixed, composition, 22,000 ohms, $\pm 10\%$ , 1/2 W	23-22K	B EB 2231
R285	Resistor: fixed, composition, 3 megohms, $\pm 5\%$ , 1/2 W	23-5M-5	B EB 2755
R286	Resistor: fixed, composition, 18,000 ohms, $\pm 10\%$ , 1/2 W	24-18K	B B 1831
R287, R288	Resistor: fixed, glass body, 20,000 ohms, $\pm 5\%$ , 3 W	333-20K-5	AB LP-3
R289	Resistor: fixed, metal film on glass body, 6500 ohms, $\pm 5\%$ , 3 W	333-6500-5	AB LP-3
R290	Resistor: variable, composition, potentiometer 500,000 ohms, $\pm 30\%$ , 1/4 W	210-146	BO U-70 special
R291	Resistor: fixed, composition, 10,000 ohms, $\pm 1\%$ , 1 W	31-10K	NN DC-1
R292	Resistor: fixed, composition, 6.8 megohms, $\pm 5\%$ , 1/2 W	23-6.8M	B EB 6855
R293	Resistor: fixed, composition, 220,000 ohms, $\pm 10\%$ , 1/2 W	23-220K	B EB 2241
R294	Resistor: fixed, deposited carbon, 100,000 ohms, $\pm 1\%$ , 1 W	31-100K	NN DC-1
R295	Resistor: fixed, composition, 100 ohms, $\pm 1\%$ , 1/2 W	33-100	NN DC-1/2B
R296	Resistor: fixed, carbon film on ceramic body, 10.2K ohms, $\pm 1\%$ , 1 W	31-10.2K	NN DC-1
R297	Resistor: fixed, carbon film on ceramic body, 6.49K ohms, $\pm 1\%$ , 1/2 W	33-6.49K	NN DC-1/2 C
R298	Resistor: fixed, carbon film on ceramic body, 2.10K ohms, $\pm 1\%$ , 1/2 W	33-2.10K	NN DC-1/2 C
R299	Resistor: fixed, deposited carbon film, 1.03K ohms, $\pm 1\%$ , 1/2 W	33-1.03K	NN DC-1/2C
R300	Resistor: fixed, carbon film on ceramic body, 608 ohms, $\pm 1\%$ , 1/2 W	33-608	NN DC-1/2C
R301	Resistor: fixed, carbon film on ceramic body, 201 ohms, $\pm 1\%$ , 1/2 W	33-201	NN DC-1/2 C
R302	Resistor: fixed, composition, 100 ohms $\pm 1\%$ , 1/2 W	33-100	NN DC-1/2B

\*See "List of Manufacturers Code Letters for Replaceable Parts Table".

TABLE OF REPLACEABLE PARTS

Circuit Ref.	Description	Stock No.	Mfr. * & Mfrs. Designation
	<u>CALIBRATOR AND HIGH VOLTAGE (CONT'D.)</u>		
R303	Resistor: fixed, deposited carbon film, 60 ohms, $\pm 1\%$ , 1/2 W	33-60	NN DC-1/2
R304	Resistor: fixed, deposited carbon film, 40 ohms, $\pm 1\%$ , 1/2 W	33-40	NN DC-1/2C
R305	Resistor: fixed, composition, 100 ohms, $\pm 10\%$ , 1/2 W	23-100	B EB 1011
S9	See Z5		
S10	Switch, SPDT, toggle, 125V, 3 amp.	310-12	CR, 81027
T1	R.F. Transformer Assembly	150A-11A	HP
V27	Tube: electron, 6AU5GT	212-6AU5GT	ZZ
V28	Tube: electron, 12AU7	212-12AU7	ZZ
V29, V30	Tube: electron, 3A2	212-3A2	ZZ
V31	Ray tube: cathode, 5 amp.*	212-5 amp* P1, P7, P11 per customer request.	ZZ
V32	Tube: electron, 6U8	212-6U8	ZZ
XV27	Socket, tube, octal	120-27	AE, 609
XV28	Socket: electric tube, 9 pin miniature type	120-49	H, 20907
XV29, XV30	Socket: hi-volt rectifier	150A-11A-4	HP
XV31	Socket: CRT, 14 pin	150A-52B	HP
XV32	Socket: electric tube, 9 pin miniature type	120-49	H, 20907
Z20	Control board and Calibrator (less calibrator switch)	150A-65C	HP
Z21	High Voltage Rectifier Assembly	150A-11A	HP
Z5	Calibrator Switch Assembly	150A-19E	HP
	Knob, 1-5/8", bar, w/pointer	G-74N	HP
	Knob, 3/4", black (3)	G-74D	HP
	Insulator, ceramic, 1/2" x 5/8" (2)	34-10	G, 9TS-510
	Clip, tube contact (2)	140-25	Fed. Screw Prod. Company

\* See "List of Manufacturers Code Letters for Replaceable Parts Table".

TABLE OF REPLACEABLE PARTS

Circuit Ref.	Description	Stock No.	Mfr. * & Mfrs. Designation
<u>LOW VOLTAGE POWER SUPPLY</u>			
B1	Fan, motor, A. C.	314-29	L. Scruggs Co. Model 103-1465
B1A	Blade, fan	314-30	BD, DUH-731-5
C131	Capacitor: fixed, ceramic dielectric, .01 $\mu$ f, tol. +100%, -0%, 1000 vdcw	15-43	CC 36C99
C132A/B	Capacitor: fixed, electrolytic, 2 section 120 x 40 $\mu$ f, 400 vdcw	18-51"S"	CC #32D
C133	Capacitor: fixed, ceramic dielectric, .01 $\mu$ f, tol. +100%, -0%, 1000 vdcw	15-43	CC 36C99
C134A/B	Capacitor: fixed, electrolytic, 2 section, 120 x 40 $\mu$ f, 400 vdcw	18-51 "S"	CC #32D
C135	Capacitor: fixed, ceramic dielectric, .01 $\mu$ f, tol. +100%, -0%, 1000 vdcw	15-43	CC 36C99
C136A/B	Capacitor: fixed, electrolytic, 4 sections, 20 $\mu$ f/sect., 450 vdcw	18-42	X FP 444
C137A/B	Capacitor: fixed, electrolytic, 2 sections, 120 x 40 $\mu$ fd, 400 vdcw	18-51 "S"	CC Type 17D
C138A/B	Capacitor: fixed, electrolytic, 2 section 120 x 40 $\mu$ f, 400 vdcw	18-51 "S"	CC #32D
C139	Capacitor: fixed, ceramic dielectric, .01 $\mu$ f, tol. +100%, -0%, 1000 vdcw	15-43	CC 36C99
C140	Capacitor: fixed, electrolytic, 4 sections, 20 $\mu$ f/sect., 450 vdcw	18-42	X FP 444
C141A/B	Capacitor: fixed, electrolytic, 2 sections, 120 x 40 $\mu$ fd, 400 vdcw	18-51 "S"	CC Type 17D
C142, C143, C144, C145, C146, C147, C148, C149.	Capacitors: fixed, ceramic dielectric, .01 $\mu$ f, tol. +100%, -0%, 1000 vdcw	15-43	CC 36C99
C150, C151, C152	Capacitors: fixed, ceramic disc, .02 $\mu$ f, tol. +100%, -0%, 600 vdcw	15-85	R. M. C. Type B
F1	Fuse, cartridge, 6.25 amp., 250 V	211-61	E, MFD-6.25
F2, F3	Fuse, cartridge, 1/8 amp., 250 V	211-67	T, #312.125
I25, I26, I27, I28, I29	Lamp, incandescent	211-47	O 47
J1	Connector, female, 8 contact	125-6	HH, 26-4200-8S
J2	Socket, tube, noval	120-10	H, 44F-16388
J16	Connector, female, 8 contact	125-6	HH, 26-4200-8S

\* See "List of Manufacturers Code Letters for Replaceable Parts Table".

**TABLE OF REPLACEABLE PARTS**

Circuit Ref.	Description	Stock No.	Mfr. * & Mrs. Designation
<u>LOW VOLTAGE POWER SUPPLY (CONT 'D.)</u>			
K1	Time Delay Relay	49-24	BQ, 117-30-G
K2	Overload Relay, DPDT	49-28	Potter-Brumfield KRP 11D
K4	Relay: armature, 4PDT	49-26	Potter-Brumfield KL-17D 110V
P8, P9, P10 P13, P14, P15, P19, P21, P22, P23	Plug, cable, noval	150A-95E	HP
R311	Resistor: fixed, composition, 180,000 ohms, $\pm 10\%$ , 1 W	24-180K	B GB 1841
R312, R313	Resistor: fixed, composition, 56,000 ohms, $\pm 10\%$ , 1 W	25-56K	B HB 5631
R314	Resistor: fixed, composition, 5000 ohms, $\pm 1\%$ , 1 W	31-5000	NN DC-1
R315	Resistor: fixed, composition, 2700 ohms, $\pm 10\%$ , 1 W	24-2700	B GB 2721
R316	Resistor: fixed, composition, 100,000 ohms, $\pm 10\%$ , 2 W	25-100K	B HB 1041
R317	Resistor: fixed, non-inductive metal film on glass rod body, 5000 ohms, $\pm 10\%$ , 4 W	334-5K	AB LP-4
R318, R319	Resistor: fixed, composition, 180,000 ohms, $\pm 10\%$ , 2 W	25-180K	B HB 1841
R320	Resistor: fixed, composition, 180,000 ohms, $\pm 10\%$ , 1 W	24-180K	B GB 1841
R321	This circuit reference not assigned	-----	-----
R322	Resistor: variable, 25 ohms, $\pm 10\%$ , 3 W	210-167	I, 58
R323	Resistor: fixed, composition, 330 ohms, $\pm 10\%$ , 1 W	24-330	B GB 3311
R324	Resistor: fixed, wirewound, 800 ohms, $\pm 5\%$ , 40 W	27-23	I 8ZT
R325	Resistor: fixed, composition, 4.7 ohms, $\pm 10\%$ , 1 W	24-4.7	B GB 47G1
R326	Resistor: fixed, composition, 330,000 ohms, $\pm 10\%$ , 1/2 W	24-330K	B EB 3341
R327	Resistor: fixed, composition, 33,000 ohms, $\pm 10\%$ , 1/2 W	23-33K	B EB 3331
R328	Resistor: fixed, composition, 1 megohm, $\pm 10\%$ , 1/2 W	23-1M	B EB 1051

\* See "List of Manufacturers Code Letters for Replaceable Parts Table".

TABLE OF REPLACEABLE PARTS

Circuit Ref.	Description	Ⓢ Stock No.	Mfr. * & Mfrs. Designation
	<u>LOW VOLTAGE POWER SUPPLY (CONT'D.)</u>		
R329	Resistor: fixed, composition, 150,000 ohms, ±10%, 1/2 W	23-150K	B EB 1541
R330, R331	Resistor: fixed, composition, 680 ohms, ±10%, 1/2 W	23-680	B EB 6811
R322A/B	Resistor: fixed, wirewound, 4500 ohms, ±5%, 30 W	27-41	TruOhm OR-30
R333, R334, R335	Resistor: fixed, composition, 33 ohms, ±10%, 1/2 W	23-33	B EB 3301
R336	Resistor: fixed, deposited carbon, 284,000 ohms, ±10%, 1 W	31-284K	NN DC-1
R337	Resistor: fixed, deposited carbon, 820,000 ohms, ±1%, 1 W	31-820K	NN DC-1
R338, R339	These circuit references not assigned		
R340	Resistor: fixed, composition, 2.7 ohms, ±10%, 1 W	24-2.7	B GB 2761
R341	Resistor: fixed, composition, 3.3 megohms, ±10%, 1/2 W	23-3.3M	B EB 3351
R342	Resistor: fixed, composition, 68,000 ohms, ±10%, 1/2 W	23-68K	B EB 6831
R343	Resistor: fixed, composition, 1 megohm, ±10%, 1/2 W	23-1M	B EB 1051
R344	Resistor: fixed, composition, 330,000 ohms, ±10%, 1/2 W	23-330K	B EB 3341
R345, R346	Resistor: fixed, composition, 680 ohms, ±10%, 1/2 W	23-680	B EB 6811
R347A/B	Resistor: fixed, wirewound, 2000 ohms, ±5%, 40 W	27-40	TruOhm OR-40
R348, R349, R350	Resistor: fixed, composition, 33 ohms, ±10%, 1/2 W	23-33	B EB 3301
R351	Resistor: fixed, deposited carbon, 316,000 ohms, ±1%, 1 W	31-316K	NN DC-1
R352	Resistor: fixed, composition, 100,000 ohms, ±10%, 1/2 W	23-100K	B EB 1041
R353	Resistor: fixed, deposited carbon, 180,000 ohms, ±1%, 1/2 W	33-180K	NN DC-1/2C
R354	Resistor: fixed, composition, 4.7 ohms, ±10%, 1 W	24-4.7	B GB 47G1
R355	Resistor: fixed, composition, 2.2 megohms, ±10%, 1/2 W	23-2.2M	B EB 2251
R356	Resistor: fixed, composition, 33,000 ohms, ±10%, 1/2 W	23-33K	B EB 3331

\* See "List of Manufacturers Code Letters for Replaceable Parts Table".

TABLE OF REPLACEABLE PARTS

Circuit Ref.	Description	Ⓟ Stock No.	Mfr. * & Mfrs. Designation
<u>LOW VOLTAGE POWER SUPPLY (CONT'D.)</u>			
R357	Resistor: fixed, composition, 1.5 megohms, ±10%, 1/2 W	23-1.5M	B EB 1551
R358	Resistor: fixed, composition, 680 ohms, ±10%, 1/2 W	23-680	B EB 6811
R359	Resistor: fixed, wirewound, 1800 ohms, ±5%, 30 W	27-42	TruOhm OR-30
R360	Resistor: fixed, composition, 56,000 ohms, ±10%, 1/2 W	23-56K	B EB 5631
R361, R362	Resistor: fixed, composition, 33 ohms, ±10%, 1/2 W	23-33	B EB 3301
R363	Resistor: fixed, deposited carbon, 252,000 ohms, ±1%, 1/2 W	33-252K	NN DC-1/2C
R364	Resistor: fixed, composition, 2.7 ohms, ±10%, 1 W	24-2.7	B GB 2761
R365	Resistor: fixed, deposited carbon, 284,000 ohms, ±1%, 1 W	31-284K	NN DC-1
R366	Resistor: fixed, composition, 1.5 megohms, ±10%, 1/2 W	23-1.5M	B EB 1551
R367, R368	Resistor: fixed, composition, 680 ohms, ±10%, 1/2 W	23-680	B EB 6811
R369	Resistor: fixed, wirewound, 1000 ohms, ±5%, 40 W	27-37	TruOhm OR-40
R370, R371, R372	Resistor: fixed, composition, 33 ohms, ±10%, 1/2 W	23-33	B EB 3301
R373	Resistor: fixed, composition, 470,000 ohms, ±10%, 1/2 W	23-470K	B EB 4741
R374	Resistor: fixed, composition, 10,000 ohms, ±10%, 1/2 W	23-10K	B EB 1031
R375	Resistor: fixed, composition, 220,000 ohms, ±10%, 1/2 W	23-220K	B EB 2241
R376	Resistor: fixed, composition, 27,000 ohms, ±10%, 1/2 W	24-27K	B EB 2731
R377	Resistor: fixed, composition, 100,000 ohms, ±10%, 1/2 W	23-100K	B EB 1041
R378	Resistor: fixed, deposited carbon, 136.7K ohms, ±1%, 1/2 W	33-136.7K	NN DC-1/2C
R379	Resistor: variable, composition, potentiometer, linear taper, 50,000 ohms, ±30%, 1/4 W	210-137	BO UPE-70 special
R380, R381	Resistor: fixed, deposited carbon, 180,000 ohms, ±1%, 1/2 W	33-180K	NN DC-1/2C

\*See "List of Manufacturers Code Letters for Replaceable Parts Table".

TABLE OF REPLACEABLE PARTS

Circuit Ref.	Description	Ⓢ Stock No.	Mfr. * & Mfrs. Designation
	<u>LOW VOLTAGE POWER SUPPLY (CONT'D.)</u>		
R382	Resistor: variable, composition, potentiometer, linear taper, 50,000 ohms, ±30%, 1/4 W	210-137	BO UPE-70 special
R383	Resistor: fixed, deposited carbon, 136.7K ohms, ±1%, 1/2 W	33-136.7K	NN DC-1/2C
R384	Resistor: fixed, composition, 470,000 ohms, ±10%, 1/2 W	23-470K	B EB 4741
R385	Resistor: fixed, composition, 180,000 ohms, ±10%, 1/2 W	23-180K	B EB 1841
R386	Resistor: fixed, composition, 1.2 megohms, ±10%, 1/2 W	23-1.2M	B EB 1251
R387	Resistor: fixed, composition, 1 megohm, ±10%, 1/2 W	23-1M	B EB 1051
R388, R389	These circuit references not assigned		
R390	Resistor: fixed, composition, 100 ohms, ±10%, 1/2 W	23-100	B EB 1011
R391	Resistor: fixed, composition, 100,000 ohms, ±10%, 1/2 W	23-100K	B EB 1041
R392	This circuit reference not assigned		
R393	Resistor: fixed, composition, 100 ohms, ±10%, 1 W	24-100	B GB 1011
R394	Resistor: fixed, composition, 22 ohms, ±10%, 1/2 W	23-22	B EB 2201
R395	Resistor: fixed, composition, 100 ohms, ±10%, 1/2 W	23-100	B EB 1011
R396	Resistor: fixed, composition, 100 ohms, ±10%, 1 W	24-100	B GB 1011
R397	This circuit reference not assigned		
R398, R399	Resistor: fixed, wirewound, 1000 ohms, ±5%, 40 W	27-37	AS Type OR-40
RT 301 RT 302	Thermistor: disc type, 10 ohms, ±10% @ 25°C, standard radial leads, supplied on instruments wired for 230V operation only.	211-73	Carboloy D-754
S11	Switch, toggle, DPDT	310-54	CR, 81027CE
S12	Switch, thermostat, SPST	310-194	BA, C4370-8-10
SR1	Rectifier, metallic, selenium	212-120	BV, 5B1SDBKX
SR2	Rectifier, metallic, selenium	212-118	BV, C5B1SDBKX
SR3	Rectifier, metallic, selenium	212-121	BV, B7B1SDBKX
SR4	Rectifier, metallic, selenium	212-119	BV, 5B1SDBKX

\* See "List of Manufacturers Code Letters for Replaceable Parts Table".



TABLE OF REPLACEABLE PARTS

Circuit Ref.	Description	Ⓟ Stock No.	Mfr. * & Mfrs. Designation
<u>LOW VOLTAGE POWER SUPPLY (CONT'D.)</u>			
T2	Transformer, power	910-142	Paeco
T3	Transformer, plate	910-143	Paeco
V33, V34, V35, V37, V38, V39, V41, V42, V44, V45, V46	12B4A Series Regulators	212-12B4A	ZZ
V50	12B4A Shunt Regulator	212-12B4A	ZZ
V36, V40, V43, V47	6BH6, control	212-6BH6	ZZ
V48	5651 reference	212-5651	ZZ
V49	12AX7 control	212-12AX7	ZZ
XF1, XF2, XF3	Fuseholder	140-16	T, 342003
XI25	Lampholder with jewel, pilot	145-21	II, 95-810B-937
XI26, XI27, XI28, XI29	Lampholder, scale light	145-18	Ucinite 180151
XK1	Socket, tube, noval, 9 contact	120-10	H, 44F-16388
XK2	Socket, tube, octal	120-7	H, 51B-16388
XV33, XV34, XV35, XV37, XV38, XV39, XV41, XV42, XV43, XV44, XV45, XV46, XV47, XV48, XV49, XV50	Sockets, tube, noval	120-49	H, 20907
XV36, XV40	Sockets, tube, 7 pin	120-48	H, 20906
Z22	Low Voltage Regulator	150A-65D	HP
	Knob, 3/4", scale light	G-74D	HP
	Mount, vibrator fan (4)	149-37	U. S. Rubber A-321

\*See "List of Manufacturers Code Letters for Replaceable Parts Table".

TABLE OF REPLACEABLE PARTS

Circuit Ref.	Description	<sup>hp</sup> Stock No.	Mfr. * & Mfrs. Designation
<u>MODEL 152A</u>			
C501	Capacitor: fixed, mylar dielectric, 0.1 $\mu$ f, $\pm$ 10%, 600 vdcw	16-104	Goodall Type 620M
C502	Capacitor: fixed, ceramic, dielectric, .01 $\mu$ f, tol. +100%, -0%, 1000 vdcw	15-43	CC 36C99
C503 thru 518	Capacitor: variable, polystyrene dielectric, 0.7 - 3.0 $\mu$ f	13-30	L Style 535-16
C519	Capacitor: variable, plastic, dielectric, 0.7 - 3.0 $\mu$ f, 350 vdcw	13-26	L 535-15
C521	Capacitor: fixed, ceramic disc, .02 $\mu$ f, tol. +100%, -0%, 600 vdcw	15-85	G DD-203
C523	Capacitor: fixed, ceramic dielectric, 47 $\mu$ f, $\pm$ 5%, 500 vdcw, NPO temp. coeff.	15-34	K SI 47 $\mu$ f $\pm$ 5%NPO
C524	Capacitor: fixed, ceramic dielectric, 110 $\mu$ f, $\pm$ 2%, 500 vdcw	15-22	K Type SI-19
C525	Capacitor: fixed, ceramic dielectric .01 $\mu$ f, tol. +100%, -0%, 1000 vdcw	15-43	K Type BPD .01
C526	Capacitor: fixed, ceramic disc, .02 $\mu$ f, tol. +100%, -0%, 600 vdcw	15-85	G DD-203
C527, 528	Capacitor: fixed, mica, 47 $\mu$ f, $\pm$ 5%, 300 vdcw	14-74	V Type PQ
C529	Capacitor: fixed, ceramic dielectric, .01 $\mu$ f, tol. +100%, -0%, 1000 vdcw	15-43	CC 36C99
C530, 531	Capacitor: variable, trimmer, ceramic, 5-25 $\mu$ f, NPO temp. coeff.	13-28	L Style 557-23
C532	Capacitor: fixed, mylar dielectric, 0.1 $\mu$ f, $\pm$ 10%, 600 vdcw	16-104	Goodall Type 620M
C533	Capacitor: fixed, ceramic dielectric, .01 $\mu$ f, tol. +100%, -0%, 1000 vdcw	15-43	K Type BPD. 01
C534, 535	Capacitor: variable, ceramic dielectric, 5-25 $\mu$ f,	13-35	L Style 557-30-000
C536	This circuit reference not assigned		
C537	Capacitor: fixed, titanium dioxide dielectric, 3.3 $\mu$ f, $\pm$ 10%,	15-78	DD GA-5
C538 thru 541	Capacitor: fixed, titanium dioxide dielectric, 2.2 $\mu$ f, $\pm$ 10%, 500 vdcw	15-52	DD GA-4
C542	This circuit reference not assigned		
C543	Same as C537		
C544 thru 547	Capacitor: fixed, titanium dioxide dielectric, 2.2 $\mu$ f, $\pm$ 10%, 500 vdcw	15-52	DD GA-4

\* See "List of Manufacturers Code Letters for Replaceable Parts Table".

**TABLE OF REPLACEABLE PARTS**

Circuit Ref.	Description	Ⓢ Stock No.	Mfr. * & Mfrs. Designation
<u>MODEL 152A (CONT'D.)</u>			
C548, 549	Capacitor: variable, polystyrene dielectric, 0.7-3.0 $\mu\mu\text{f}$	13-30	L Style 535-16
C550, 551	Capacitor: variable, plastic dielectric, 0.7-3.0 $\mu\mu\text{f}$ , 300 vdcw	13-26	L 535-15
C552, 553	Capacitor: fixed, ceramic dielectric, .01 $\mu\text{f}$ , tol. +100%, -0%, 1000 vdcw	15-43	CC 36C99
CR501, 502, 503	Crystal, rectifier, diode	212-G11A	BU HD-1235
J501, 502	Connector, BNC	125-9	LL, 5126
L501, 502	Coil, single layer, 3.9 $\mu\text{h}$	48-56	CG 212-11
L503A/B, L504A/B, L505A/B, L506A/B	R. F. Coil Assembly, 42 $\mu\text{h}/15 \mu\text{h}$ <u>Note:</u> Refer to factory service department. Replacement requires special test equipment not generally available.		HP
L507, 508	Not assigned		
L509	Coil, radio frequency, 500 $\mu\text{h}$	48-37	CG 1500-15
L510, 511	Coil, single layer, 3.9 $\mu\text{h}$	48-56	CG 212-11
P503, 504	Connector, male, 8 contact	125-5	HH, 26-4100-8P
R501	Resistor: fixed, carbon film on ceramic body, 500,000 ohms, $\pm 1\%$ , 1/2 W	33-500KR	NN DC-1/2C
R502	Resistor: fixed, carbon film on ceramic body, 1 megohm, $\pm 1\%$ , 1/2 W	33-1MR	NN DC-1/2C
R503	Resistor: fixed, deposited carbon, 1 megohm, $\pm 1\%$ , 1/2 W	33-1M	NN DC-1/2A
R504	Same as R502		
R505	Resistor: fixed, carbon film on ceramic body, 750,000 ohms, $\pm 1\%$ , 1/2 W	33-750KR	NN DC-1/2C
R506	Resistor: fixed, carbon film on ceramic body, 333,000 ohms, $\pm 1\%$ , 1/2 W	33-333KR	NN DC-1/2C
R507	Resistor: fixed, carbon film on ceramic body, 900,000 ohms, $\pm 1\%$ , 1/2 W	33-900KR	NN DC-1/2C
R508	Resistor: fixed, carbon film on ceramic body, 111,000 ohms, $\pm 1\%$ , 1/2 W	33-111KR	NN DC-1/2C
R509	Resistor: fixed, carbon film on ceramic body, 950,000 ohms, $\pm 1\%$ , 1/2 W	33-950KR	NN DC-1/2C
R510	Resistor: fixed, carbon film on ceramic body, 52.6K ohms, $\pm 1\%$ , 1/2 W	33-52.6KR	NN DC-1/2C
R511	Resistor: fixed, carbon film on ceramic body, 975,000 ohms, $\pm 1\%$ , 1/2 W	33-975KR	NN DC-1/2C
R512	Resistor: fixed, carbon film on ceramic body, 25.6K ohms, $\pm 1\%$ , 1/2 W	33-25.6KR	NN DC-1/2C

\* See "List of Manufacturers Code Letters for Replaceable Parts Table".

TABLE OF REPLACEABLE PARTS

Circuit Ref.	Description	Stock No.	Mfr. * & Mfrs. Designation
<u>MODEL 152A (CONT'D.)</u>			
R513, 514, 515	Resistor: fixed, composition, 56 ohms, $\pm 10\%$ , 1/2 W	23-56	B EB 5601
R516	Resistor: fixed, composition, 100 ohms, $\pm 10\%$ , 1/2 W	23-100	B EB 1011
R517, 518	Resistor: fixed, composition, 27,000 ohms, $\pm 10\%$ , 2 W	25-27K	B EB 2731
R519	Resistor: variable, 200 ohms, $\pm 20\%$ , 1/4 W	210-158	BO Type 70
R520	Resistor: fixed, composition, 56 ohms, $\pm 10\%$ , 1/2 W	23-56	B EB 5601
R521, 522	Resistor: fixed, deposited carbon, 20,000 ohms, $\pm 5\%$ , 2 W	333-20K-5	AB
R523	Resistor: variable, composition, linear taper, 1000 ohms, $\pm 30\%$	210-143	BO, CY-9435 RGC-45
R524	Resistor: variable, 200 ohms, $\pm 20\%$ , 1/4 W	210-158	BO, Type 70
R525, 526	Resistor: fixed, composition, 820,000 ohms, $\pm 10\%$ , 1/2 W	23-820K	B EB 8241
R527	Resistor: fixed, composition, 56,000 ohms, $\pm 10\%$ , 1/2 W	23-56K	B EB 5631
R528A/B	Resistor: variable, composition, 100,000 ohms, $\pm 10\%$ , 2 W	210-131	BO CTS 2-95CV
R529	Resistor: fixed, composition, 10,000 ohms, $\pm 10\%$ , 1/2 W	23-10K	B EB 1031
R530	Resistor: fixed, composition, 56,000 ohms, $\pm 10\%$ , 1/2 W	23-56K	B EB 5631
R531	Resistor: fixed, composition, 10,000 ohms, $\pm 10\%$ , 1/2 W	23-10K	B EB 1031
R532, 533	Resistor: fixed, deposited carbon, 680 ohms, $\pm 1\%$ , 1/2 W	33-680	NN DC-1/2C
R534, 535	Resistor: fixed, deposited carbon, 2000 ohms, $\pm 1\%$ , 1/2 W	33-2000	NN DC-1/2C
R536	Resistor: fixed, composition, 470 ohms, $\pm 10\%$ , 1/2 W	23-470	B EB 4711
R537	Resistor: fixed, composition, 10,000 ohms, $\pm 10\%$ , 1/2 W	23-10K	B EB 1031
R538	Resistor: fixed, composition, 15,000 ohms, $\pm 10\%$ , 1 W	24-15K	B GB 1531
R539	Resistor: fixed, composition, 56 ohms, $\pm 10\%$ , 1/2 W	23-56	B EB 5601

\* See "List of Manufacturers Code Letters for Replaceable Parts Table".

TABLE OF REPLACEABLE PARTS

Circuit Ref.	Description	Ⓟ Stock No.	Mfr. * & Mfrs. Designation
<u>MODEL 152A (CONT'D.)</u>			
R540	Resistor: fixed, composition, 100,000 ohms, ±10%, 1/2 W	23-100K	B EB 1041
R541	Resistor: fixed, composition, 150,000 ohms, ±10%, 1/2 W	23-150K	B EB 1541
R542	Resistor: fixed, composition, 5600 ohms, ±10%, 1/2 W	23-5600	B EB 5621
R543	Resistor: fixed, composition, 100 ohms, ±10%, 1/2 W	23-100	B EB 1011
R544	Resistor: fixed, composition, 100,000 ohms, ±10%, 1/2 W	23-100K	B EB 1041
R545	Resistor: fixed, composition, 4700 ohms, ±10%, 1 W	24-4700	B GB 4721
R546	Resistor: fixed, composition, 470 ohms, ±10%, 1/2 W	23-470	B EB 4711
R547, 548	Resistor: fixed, composition, 5600 ohms, ±10%, 1 W	24-5600	B GB 5621
R549	Resistor: fixed, composition, 360,000 ohms, ±5%, 1/2 W	23-360K-5	B EB 3645
R550, 551	Resistor: fixed, deposited carbon, 252,000 ohms, ±1%, 1/2 W	33-252K	NN DC-1/2C
R552	Resistor: fixed, composition, 360,000 ohms, ±5%, 1/2 W	23-360K-5	B EB 3645
R553	Resistor: fixed, composition, 47,000 ohms, ±10%, 1/2 W	23-47K	B EB 4731
R554	Resistor: fixed, composition, 3300 ohms, ±10%, 1/2 W	23-3300	B EB 3321
R555, 556	Resistor: fixed, composition, 150,000 ohms, ±10%, 1/2 W	23-150K	B EB 1541
R557	Resistor: fixed, glass body, 10,000 ohms, ±5%, 5 W	335-10K-5	AB LP-5
R558, 559	Resistor: fixed, deposited carbon film, 66,000 ohms, ±1%, 1/2 W	33-66K	NN DC-1/2C
R560	Resistor: fixed, deposited carbon film, 140,000 ohms, ±1%, 1/2 W	33-140K	NN DC-1/2B
R561	Resistor: variable, composition, linear taper, 5000 ohms, ±30%, 1/3 W	210-134	BO UPE-70-special
R562	Resistor: fixed, deposited carbon film, 140,000 ohms, ±1%, 1/2 W	33-140K	NN DC-1/2B
R563	Resistor: fixed, composition, 56 ohms, ±10%, 1/2 W	23-56	B EB 5601

\* See "List of Manufacturers Code Letters for Replaceable Parts Table".

TABLE OF REPLACEABLE PARTS

Circuit Ref.	Description	Ⓟ Stock No.	Mfr. * & Mfrs. Designation
R564, 565	Resistor: fixed, composition, 12,000 ohms, ±10%, 2 W	25-12K	B EB 1231
R565	Resistor: fixed, composition, 56 ohms, ±10%, 1/2 W	23-56	B EB 5601
R567	Resistor: fixed, carbon film on ceramic body, 990,000 ohms, ±1%, 1/2 W	33-990KR	NN DC-1/2C
R568	Resistor: fixed, carbon film on ceramic body, 10.1K ohms, ±1%, 1/2 W	33-10.1KR	NN DC-1/2C
R569	Resistor: fixed, deposited carbon, 1 megohm, ±1%, 1/2 W	33-1M	NN DC-1/2A
R570	Resistor: fixed, composition, 1 megohm, ±10%, 1/2 W	23-1M	B EB 1051
R571	Resistor: fixed, carbon film on ceramic body, 995,000 ohms, ±1%, 1/2 W	33-995KR	NN DC-1/2C
R572	Resistor: fixed, carbon film on ceramic body, 5.03K ohms, ±1%, 1/2 W	33-5.03KR	NN DC-1/2C
R573	Resistor: fixed, carbon film on ceramic body, 1 megohm, ±1%, 1/2 W	33-1MR	NN DC-1/2C
R574	Resistor: fixed, carbon film on ceramic body, 2.51K ohms, ±1%, 1/2 W	33-2.51KR	NN DC-1/2C
R575, 576	Resistor: fixed, composition, 1.5 megohms, ±10%, 1/2 W	23-1.5M	B EB 1551
R577, 578	These circuit references not assigned		
R579, 580, 581	Resistor: fixed, composition, 56 ohms, ±10%, 1/2 W	23-56	B EB 5601
R582	Resistor: variable, 200 ohms, ±20%, 1/4 W	210-158	BO Type 70
R583, 584	Resistor: fixed, composition, 27,000 ohms, ±10%, 2 W	25-27K	B EB 2731
R585	Resistor: fixed, composition, 100 ohms, ±10%, 1/2 W	23-100	B EB 1011
R586	Resistor: fixed, composition, 56 ohms, ±10%, 1/2 W	23-56	B EB 5601
R587, 588	Resistor: fixed, deposited carbon, 20,000 ohms, ±10%, 2 W	333-20K-5	AB
R589	Resistor: variable, 200 ohms, ±20%, 1/4 W	210-158	BO Type 70
R590	Resistor: variable, composition, linear taper, 1000 ohms, ±30%, 1/4 W	210-143	BO CY/9435RGC-45
R591, 592	Resistor: fixed, composition, 820,000 ohms, ±10%, 1/2 W	23-820K	B EB 8241

\* See "List of Manufacturers Code Letters for Replaceable Parts Table".

TABLE OF REPLACEABLE PARTS

Circuit Ref.	Description	Ⓢ Stock No.	Mfr. * & Mfrs. Designation
R593	Resistor: fixed, composition, 56,000 ohms, ±10%, 1/2 W	23-56K	B EB 5631
R594A/B	Resistor: variable, composition, 100,000 ohms, ±10%, 2 W	210-131	BO CTS 2-95CV
R595, 596	Resistor: fixed, composition, 10,000 ohms, ±10%, 1/2 W	23-10K	B EB 1031
R597	Resistor: fixed, composition, 56,000 ohms, ±10%, 1/2 W	23-56K	B EB 5631
R598, 599	Resistor: fixed, deposited carbon, 680 ohms, ±1%, 1/2 W	33-680	NN DC-1/2C
R600, 601	Resistor: fixed, deposited carbon, 2000 ohms, ±1%, 1/2 W	33-2000	NN DC-1/2C
R602	Resistor: fixed, metal film on glass body, 1500 ohms, ±10%, 7 W	337-1500	AB LP-7
S501	Polarity Switch Assembly: (components mounted) (without components)	152A-19A 310-203	HP W
S502	VOLTS/CM Switch Assembly: (components mounted)	152A-34B	HP
S503	Vertical Presentation Switch	310-178	W
S504	Same as S501		
S505	Same as S502		
V501, 502, 503	Tube: 6BQ7A	212-6BQ7A	ZZ
V504	Tube: 6AN8	212-6AN8	ZZ
V505	Tube: 12AU7A	212-12AU7A	ZZ
V506	Tube: 6BK7A	212-6BK7A	ZZ
V507, 508, 509, 510	Tube: 6BQ7A	212-6BQ7A	ZZ
XV501 thru 510	Socket, tube, 9 pin	120-49	H 20907
Z503	Etched Circuit Assembly	152-65A	HP
	Knob: 1-5/8", bar, black (1)	G-74N	HP
	Knob: 1-5/8", hollow bar, black (4)	G-74AQ	HP
	Knob: 3/4", with arrow, red (4)	G-74AU	HP

\* See "List of Manufacturers Code Letters for Replaceable Parts Table".

TABLE OF REPLACEABLE PARTS

Circuit Ref.	Description	 Stock No.	Mfr. * & Mfrs. Designation
	<u>MISCELLANEOUS</u>		
	Probe Assembly	AC-21A	HP
	BNC to binding post adapter	AC-76A	HP
	Hood, viewing	150A-83A	HP
	Filter, light, green	150A-83B	HP
	Filter, light, blue	150A-83D	HP
	Filter, light, amber	150A-83E	HP
	Filter, air	314-32	Research Prods.
	Oil, air filter	314-18	Research Prods.
	Graticule: CRT	150A-83C	HP
	CRT Bezel Assembly		
	Green (for P1)	150A-84A	HP
	Blue (for P11)	150A-84C	HP
	Amber (for P7)	150A-84B	HP
	Rubber viewing hood (slips over end of bezel ring)	AC-83A	HP
	Plug-in Extender	150A-95L	HP

\* See "List of Manufacturers Code Letters for Replaceable Parts Table".



# LIST OF CODE LETTERS USED IN TABLE OF REPLACEABLE PARTS TO DESIGNATE THE MANUFACTURERS

Code Letter	Manufacturer	Address	Code Letter	Manufacturer	Address
A	Aerovox Corporation	New Bedford, Mass.	AI	General Ceramics & Steatite Corp.	Keasbey, N. J.
B	Allen-Bradley Company	Milwaukee 4, Wis.	AJ	The Gudeman Company	Sunnyvale, Calif.
C	Amperite Company	New York, N. Y.	AK	Hammerlund Mfg. Co., Inc.	New York 1, N. Y.
D	Arrow, Hart & Hegeman	Hartford, Conn.	AL	Industrial Condenser Corporation	Chicago 18, Ill.
E	Bussman Manufacturing Company	St. Louis, Mo.	AM	Insuline Corporation of America	Manchester, N. H.
F	Carborundum Company	Niagara Falls, N. Y.	AN	Jennings Radio Mfg. Corporation	San Jose, Calif.
G	Centralab	Milwaukee 1, Wis.	AO	E. F. Johnson Company	Waseca, Minn.
H	Cinch-Jones Mfg. Company	Chicago 24, Ill.	AP	Lenz Electric Mfg. Company	Chicago 47, Ill.
HP	Hewlett-Packard Company	Palo Alto, Calif.	AQ	Micro-Switch	Freeport, Ill.
I	Clarostat Mfg. Company	Dover, N. H.	AR	Mechanical Industries Prod. Co.	Acron 8, Ohio
J	Cornell Dubilier Elec. Company	South Plainfield, N. J.	AS	Model Eng. & Mfg., Incorporated	Huntington, Ind.
K	Hi-Q Division of Aerovox	Olean, N. Y.	AT	The Muter Company	Chicago 5, Ill.
L	Erie Resistor Corporation	Erie 6, Penn.	AU	Ohmite Mfg. Company	Skokie, Ill.
M	Fed. Telephone & Radio Corporation	Clifton, N. J.	AV	Resistance Products Company	Harrisburg, Penn.
N	General Electric Company	Schenectady 5, N. Y.	AW	Radio Condenser Company	Camden 3, N. J.
O	General Electric Supply Corporation	San Francisco, Calif.	AX	Shallcross Manufacturing Company	Collingdale, Penn.
P	Girard-Hopkins	Oakland, Calif.	AY	Solar Manufacturing Company	Los Angeles 58, Calif.
Q	Industrial Products Company	Danbury, Conn.	AZ	Sealectro Corporation	New Rochelle, N. Y.
R	International Resistance Company	Philadelphia 8, Penn.	BA	Spencer Thermostat	Attleboro, Mass.
S	Lectrohm Incorporated	Chicago 20, Ill.	BC	Stevens Manufacturing Company	Mansfield, Ohio
T	Littlefuse Incorporated	Des Plaines, Ill.	BD	Torrington Manufacturing Company	Van Nuys, Calif.
U	Maguire Industries Incorporated	Greenwich, Conn.	BE	Vector Electronic Company	Los Angeles 65, Calif.
V	Micamold Radio Corporation	Brooklyn 37, N. Y.	BF	Weston Electrical Inst. Corporation	Newark 5, N. J.
W	Oak Manufacturing Company	Chicago 10, Ill.	BG	Advance Electric & Relay Co.	Burbank, Calif.
X	P. R. Mallory Co., Incorporated	Indianapolis, Ind.	BH	E. L. DuPont	Los Angeles 58, Calif.
Y	Radio Corporation of America	Harrison, N. J.	BI	Electronics Tube Corporation	Philadelphia 18, Penn.
Z	Sangamo Electric Company	Marion, Ill.	BJ	Aircraft Radio Corporation	Boonton, N. J.
AA	Sarkes Tarzian	Bloomington, Ind.	BK	Allied Control Co., Incorporated	New York 21, N. Y.
BB	Signal Indicator Company	Brooklyn 37, N. Y.	BL	Augat Brothers, Incorporated	Attleboro, Mass.
CC	Sprague Electric Company	North Adams, Mass.	BM	Carter Radio Division	Chicago, Ill.
DD	Stackpole Carbon Company	St. Marys, Penn.	BN	CBD Hytron Radio & Electric	Danvers, Mass.
EE	Sylvania Electric Products Company	Warren, Penn.	BO	Chicago Telephone Supply	Elkhart, Ind.
FF	Western Electric Company	New York 5, N. Y.	BP	Henry L. Crowley Co., Incorporated	West Orange, N. J.
GG	Wilkor Products, Incorporated	Cleveland, Ohio	BQ	Curtiss-Wright Corporation	Carlstadt, N. J.
HH	Amphenol	Chicago 50, Ill.	BR	Allen B. DuMont Labs	Clifton, N. J.
II	Dial Light Co. of America	Brooklyn 37, N. Y.	BS	Exsel Transformer Company	Oakland, Calif.
JJ	Leecraft Manufacturing Company	New York, N. Y.	BT	General Radio Company	Cambridge 39, Mass.
KK	Switchcraft, Incorporated	Chicago 22, Ill.	BU	Hughes Aircraft Company	Culver City, Calif.
LL	Gremar Manufacturing Company	Lynn, Mass.	BV	International Rectifier Corporation	El Segundo, Calif.
MM	Carad Corporation	Redwood City, Calif.	BW	James Knight Company	Sandwich, Ill.
NN	Electra Manufacturing Company	Kansas City, Mo.	BX	Mueller Electric Company	Cleveland, Ohio
OO	Acro Manufacturing Company	Columbus 16, Ohio	BY	Precision Thermometer & Inst. Co.	Philadelphia 30, Penn.
PP	Alliance Manufacturing Company	Alliance, Ohio	BZ	Radio Essentials Incorporated	Mt. Vernon, N. Y.
QQ	Arco Electronics, Incorporated	New York 13, N. Y.	CA	Raytheon Manufacturing Company	Newton, Mass.
RR	Astron Corporation	East Newark, N. J.	CB	Tung-Sol Lamp Works, Incorporated	Newark 4, N. J.
SS	Axel Brothers Incorporated	Long Island City, N. Y.	CD	Varian Associates	Palo Alto, Calif.
TT	Belden Manufacturing Company	Chicago 44, Ill.	CE	Victory Engineering Corporation	Union, N. J.
UU	Bird Electronics Corporation	Cleveland 14, Ohio	CF	Weckesser Company	Chicago 30, Ill.
VV	Barber Colman Company	Rockford, Ill.	CG	Wilco Corporation	Indianapolis, Ind.
WW	Bud Radio Incorporated	Cleveland 3, Ohio	CH	Winchester Electric Incorporated	Santa Monica, Calif.
XX	Allen D. Cardwell Mfg. Company	Plainville, Conn.	CI	Malco Tool	Los Angeles 42, Calif.
YY	Cinema Engineering Company	Burbank, Calif.	CJ	Oxford Electric Corporation	Chicago 15, Ill.
ZZ	Any brand tube meeting RETMA characteristics.		CK	Camio-Fastner Corporation	Paramus, N. J.
AB	Corning Glass Works	Corning, N. Y.	CL	George K. Garrett	Philadelphia 34, Penn.
AC	Dale Products, Incorporated	Columbus, Neb.	CM	Union Switch	Swissvale, Penn.
AD	The Drake Mfg. Company	Chicago 22, Ill.	CN	Radio Receptor	New York 11, N. Y.
AE	Elco Corporation	Philadelphia 24, Penn.	CO	Automatic & Precision Mfg. Co.	Yonkers, N. Y.
AF	Hugh H. Eby Company	Philadelphia 44, Penn.	CP	Bassick Company	Bridgeport 2, Conn.
AG	Thomas A. Edison, Incorporated	West Orange, N. J.	CQ	Birnbach Radio Company	New York 13, N. Y.
AH	Fansteel Metallurgical Corporation	North Chicago, Ill.	CR	Fischer Specialties	Cincinnati 6, Ohio
			CS	Telefunken (The American Elite Co)	New York, N. Y.

## CLAIM FOR DAMAGE IN SHIPMENT

The instrument should be tested as soon as it is received. If it fails to operate properly, or is damaged in any way, a claim should be filed with the carrier. A full report of the damage should be obtained by the claim agent, and this report should be forwarded to us. We will then advise you of the disposition to be made of the equipment and arrange for repair or replacement. Include model number and serial number when referring to this instrument for any reason.

## WARRANTY

Hewlett-Packard Company warrants each instrument manufactured by them to be free from defects in material and workmanship. Our liability under this warranty is limited to servicing or adjusting any instrument returned to the factory for that purpose and to replace any defective parts thereof. Klystron tubes as well as other electron tubes, fuses and batteries are specifically excluded from any liability. This warranty is effective for one year after delivery to the original purchaser when the instrument is returned, transportation charges prepaid by the original purchaser, and when upon our examination it is disclosed to our satisfaction to be defective. If the fault has been caused by misuse or abnormal conditions of operation, repairs will be billed at cost. In this case, an estimate will be submitted before the work is started.

If any fault develops, the following steps should be taken:

1. Notify us, giving full details of the difficulty, and include the model number and serial number. On receipt of this information, we will give you service data or shipping instructions.
2. On receipt of shipping instructions, forward the instrument prepaid, to the factory or to the authorized repair station indicated on the instructions. If requested, an estimate of the charges will be made before the work begins provided the instrument is not covered by the warranty.

## SHIPPING

All shipments of Hewlett-Packard instruments should be made via Truck or Railway Express. The instruments should be packed in a strong exterior container and surrounded by two or three inches of excelsior or similar shock-absorbing material.

**DO NOT HESITATE TO CALL ON US**

**HEWLETT-PACKARD COMPANY**

*Laboratory Instruments for Speed and Accuracy*

275 PAGE MILL ROAD

PALO ALTO, CALIF. U.S.A.

CABLE



"HEWPACK"

